

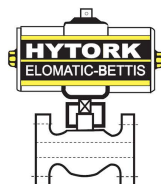

VALVE ACTUATORS

Pro-Gear Manual Override Actuator

Instruction PGMOA



ACTIONNEURS PNEUMATIQUES ¼ DE TOUR
ACTIONNEURS ELECTRIQUES
ENSEMBLES VANNES MOTORISEES

1. Instructions

1.1 General instructions

These instructions provide information about Pro-Gear manual operated Manual override actuators. They are for use by personnel who are responsible for installation, operation and maintenance of Pro-Gear manual operated actuators.

All safety messages in these instructions are marked with the exclamation symbol and the word Warning. These messages indicate procedures that must be followed exactly in order to avoid any damage to equipment or personal injury or death.



Warning

Personnel involved in the installation or maintenance of manual gear and/or valve should be constantly alert to potential emission of pipeline material and take appropriate safety precautions.

Always wear suitable protection when working with potential hazardous materials

Shut down the flow in the line before removing the actuator from the valve.

1.2 Inspection by arrival.

Your Pro-Gear manual actuator has been packaged to provide protection during shipment, however, it can be damaged in transport. Carefully inspect the unit for damage upon arrival and file a claim with the carrier if damage is apparent.

1.3 Spare- parts and information:

Whenever spare-parts and / or information concerning the gearboxes is required, please mention the type number of the gearbox which can be found on the label on top of the gearbox.

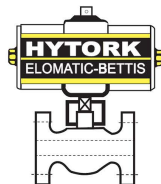

MECATORK

ACTIONNEURS PNEUMATIQUES ¼ DE TOUR
ACTIONNEURS ELECTRIQUES
ENSEMBLES VANNES MOTORISEES

2. Descriptions

2.1 General Descriptions.

The Pro-Gear MO-D series, manual operated actuator is quarter turn gear actuator. The cast iron actuator is available in 5 types.

All these types are available with a handwheel.

Each actuator has adjustable "OPEN" and "CLOSED" position stops, and may be mounted on the valve in any position depending upon valve type.

2.2 Operation.

To engage manual operation, first pull the spring loaded locking pin, then rotate the eccentric lever clockwise until the locking pin re-engages. Anti clockwise lever movement disengages manual operation and returns the system to automatic operation.

Clockwise rotation of the handwheel drives the actuator and the valve mounted below clockwise towards the closed position of the valve. A counter clockwise rotation will open the valve.

The approximate number of handwheel rotations to drive the valve 90° is depending on the model of gearbox.

NOTE: When under manual control, the valve remains locked in the last set position

2.3 Lubrication.

Whenever there are no other grease specifications given by the customer, the Pro-Gear standard grease SKALA COMPLEX LT-0 RD is used.

Unless differently specified, Pro-Gear gearboxes are filled with grease for a life-time operation.

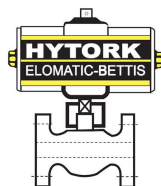

3. Adjustments

3.1 Removing an Actuator of a Valve.



Flow in the line with the actuator removed can slam the valve closed causing personal injury and damaging the flow system. Shut down the flow in the line before removing the actuator from the valve.

We refer to figure F.1. for component identification.

1. Close the Valve.
2. Remove the four (or eight) mounting screws (Bf) and lockwashers (Wf).
3. Remove the actuator from the valve.

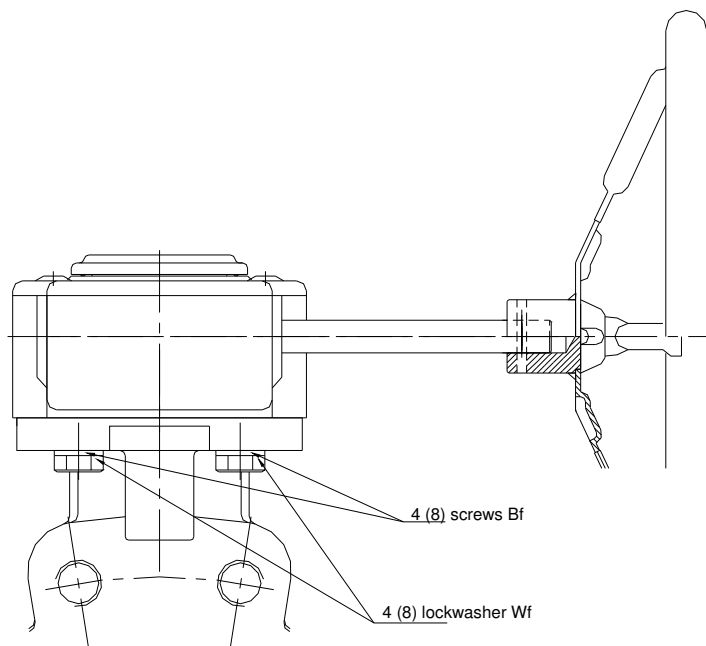
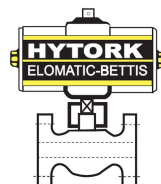

Figure F.1 component identification



MECATORK

ACTIONNEURS PNEUMATIQUES ¼ DE TOUR
ACTIONNEURS ELECTRIQUES
ENSEMBLES VANNES MOTORISEES

3.2 (Re-) Placing a Actuator on a Valve.

We refer to figure 1.F. for component identification.

1. Place both the actuator and the valve in the same position (both “OPEN” or both “CLOSED”)
2. Most of our actuators include an insertbush equipped with a key.
If the insertbush is delivered separately, or come out, (re-)place the insertbush in the correct way (if present the recess first)
3. Select the desired actuator mounting position.
Engage the actuator with the valve shaft, and slide the actuator into position on the top of the valve.

N.B. Pro-Gear G.m.b.H. recommends the assembly of a suitable gasket/sealing between the actuator and the mountingflange of the valve.

4. Mount the actuator (and the recommended gasket/sealing) to the valve with the four (or eight) mounting screws (Bf).
Do not forget the lockwashers (Wf)!
Tighten the screws as shown in table A.
5. Adjust the “OPEN” and “CLOSED” positions stops as shown in section 3.3
“Adjusting the position stop screws”

Fastener dimension	M6	M8	M10	M12	M16	M20	M30	M36
Actuator mounting screw: Steel	8,5 Nm	20,5 Nm	41 Nm	71 Nm	170 Nm	350 Nm	1190 Nm	2100 Nm
Actuator mounting screw : Stainless Steel (class 70)	5,9 Nm	14,5 Nm	30 Nm	50 Nm	121 Nm	244 Nm	445 Nm	651 Nm

Table A Fastener Torque Requirements

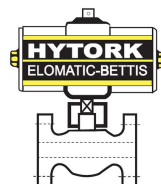

3.3 Adjusting the position stop screws.

The open and closed position stops prevent the manual override from rotating beyond the open and closed position of the valve. Each stop is adjustable .
The stops are not preset by the gearbox manufacturer. Adjusting has to be done when the gearbox is (re)mounted on the valve.
The adjustment has to be done as described below:

We refer to figure T.1 (below) for component identification: also refer to the valve instructions for specific closed-position requirements for the valve.

To adjust the closed position stop:

1. Remove the protection cap (A) from the jam nut on the closed position stop screw.
2. Loosen the jam nut (B) on the closed position stop screw, and back out the stop screw a few turns.
3. Turn the handwheel (or other operating device) so that the valve is in the closed position.
4. Turn the closed position stop screw clockwise until the resistance is felt from the stop screw contacting the gear inside the actuator.
5. Hold the stop screw from turning, and tighten the jam nut (B).
6. Put back the protection cap (A) on the jam nut.

To adjust the open position stop:

1. Remove the protection cap (A) from the jam nut on the open position stop screw.
2. Loosen the jam nut (B) on the open position stop screw, and back out the open screw a few turns.
3. Turn the handwheel (or other operating device) so that the valve is in the open position.
4. Turn the open position stop screw clockwise until the resistance is felt from the stop screw contacting the gear inside the actuator.
5. Hold the stop screw from turning, and tighten the jam nut (B).
6. Put back the protection cap (A) on the jam nut.

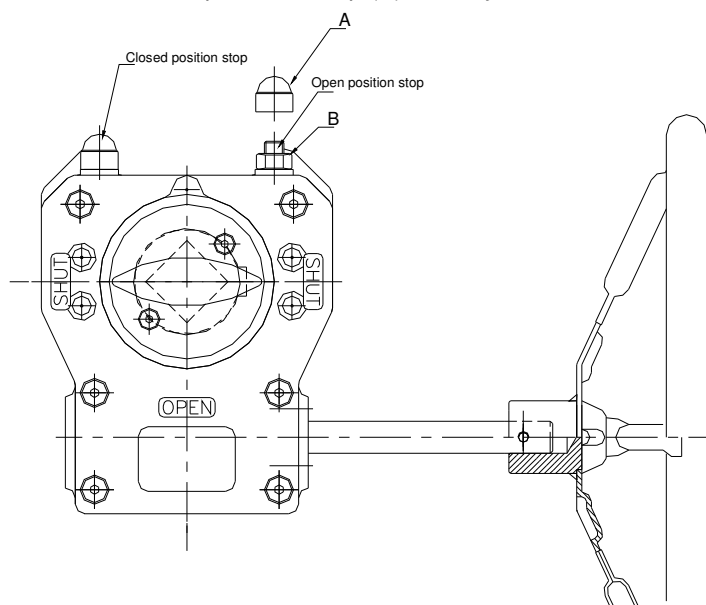

Figure T.1 component identification



4. Safety devices

4.1 Safety relief valve.

The MO-D gearbox can be equipped with a pneumatic relief valve which is actuated when the override is engaged by the excentric lever. This automatically vents the pressurised air in the actuator to atmosphere and allows the override to operate the valve without air resistance. More importantly, when the failed air supply is reinstated, personell are protected from accidental operation as the air supply will continue to exhaust untill the excentric lever is moved to the auto position. Figures 2.1 and 2.2 below show the different circuit layout.

fig 2.1 double acting

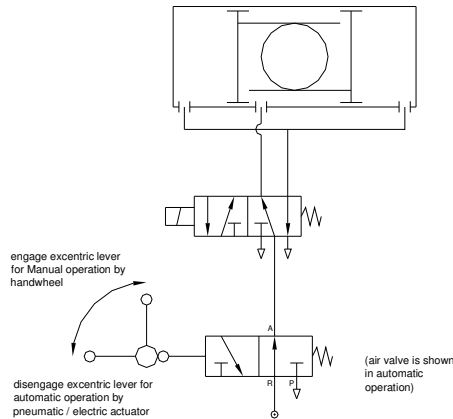

Figure 2.1 above is showing a circuit layout , air to air with local solenoid
The 3/2 air valve on the MO-D gearbox is acting as an vent valve.

Fig. 2.2 single acting

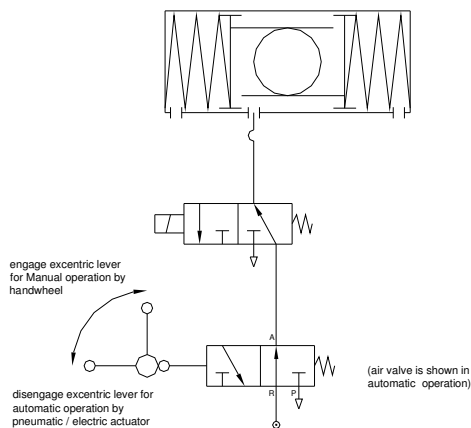

Figure 2.2 above is showing a circuit layout showing a spring return actuator with a local solenoid
The 3/2 air valve on the MO-D gearbox is acting as a vent valve.





MECATORK

ACTIONNEURS PNEUMATIQUES ¼ DE TOUR

ACTIONNEURS ELECTRIQUES

ENSEMBLES VANNES MOTORISEES

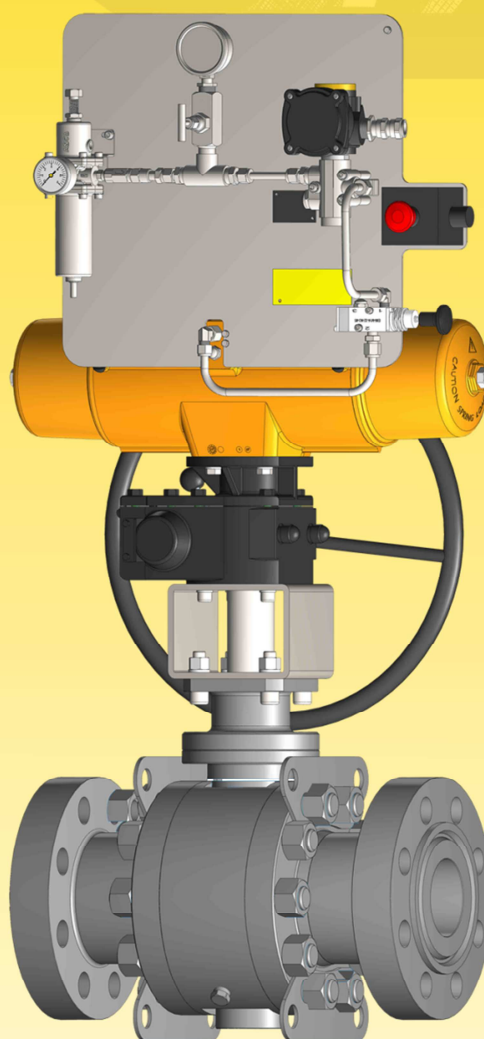
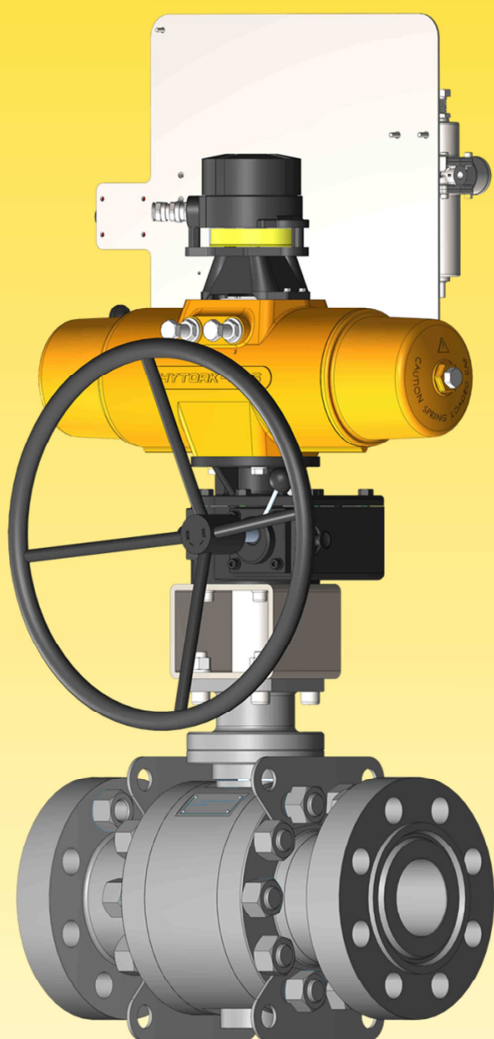

Notre Savoir-Faire

La motorisation pneumatique et électrique
de tout type de vanne 1/4 de tour
dans de multiples secteurs d'activité selon vos spécifications

info@mecatork.fr - 04 50 66 70 42