

Pos.	Qty G1	Qty G2	Description
1	1	1	Gauge block (universal)
2	2	3	Gauge 1-10 bar (0-145 psi)
3	2	2	Socket screw M4x35
4	4	4	O-ring 15.3x1.78
5	1	1	Blanking plug M5
6	1	1	Hex. socket key 2.5 mm.
7	1	1	Hex. socket key 3.0 mm.
8	1	-	Gauge 0-1.6 bar (0-23 psi)

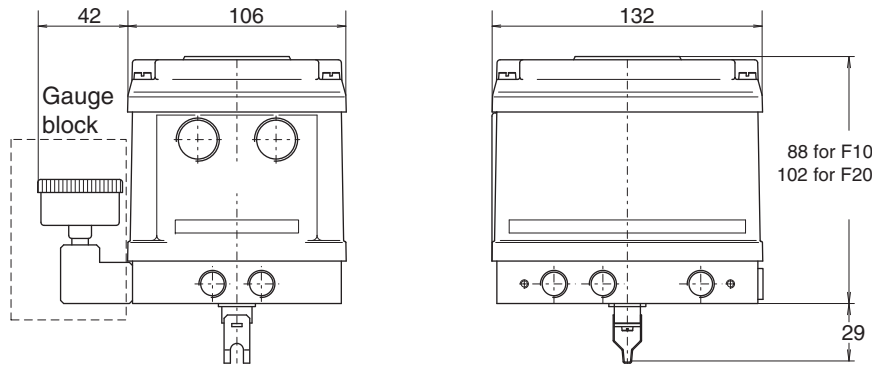
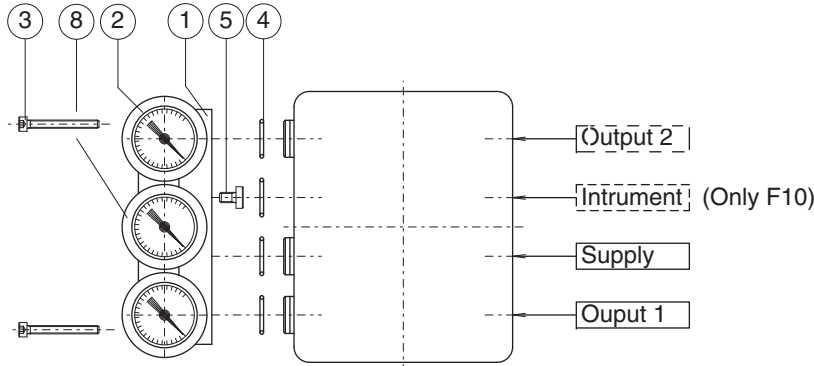

Description:

Gauge block kits are available in two forms: G1 kits have two output gauges for the actuator operating pressure and one gauge for the incoming instrument pressure. G1 gauge blocks are for basic F10 pneumatic positioners.

G2 kits have two output gauges and one gauge for the incoming supply pressure. G2 gauge blocks are for electro/pneumatic positioner, type F20.

Both kits are suitable for double acting or single acting positioners. When used on a single acting actuator only one of the two output gauges will show a pressure. If required the inactive gauge may be replaced with a (G 1/8") blanking plug and the removed gauge stored to be used as a spare.

The gauges are heavy duty type with stainless steel housings and are graduated in metric (bar) and Imperial (psi) units.

Construction:

Gauge blocks are normally attached to the positioner base at the opposite side to the air supply and output ports. Alternatively they may be fitted to the air inlet face, this way is more suitable for linear actuators.

Specification:

- | | | |
|---------------|-------------------|--------------|
| Gauges | : G1 | G2 |
| - Input | : 0 to 1.6 bar | 0 to 10 bar |
| | : 0 to 30 psi | 0 to 160 psi |
| - Output | : 0 to 10 bar. | 0 to 10 bar |
| | : 0 to 160 psi. | 0 to 160 psi |
| - Connections | : G 1/8" | |
| - Housing | : Stainless steel | |
| Temperature | : -20° to +80°C | |
| Gauge block | : Aluminium Alloy | |
| Finish | : Anodized | |

Identification:

- Factory Option : Add "+G1" to the basic positioner number.
ie. F10+G1
- Kit Option : G1-F10

Note: When supplied as a kit option, all the components as shown are included, together with installation instructions.