

Pos.	Qty.	Description
1	1	S2 switch module
2	4	Spacer standoff screws

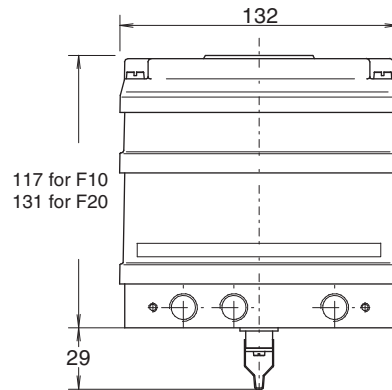
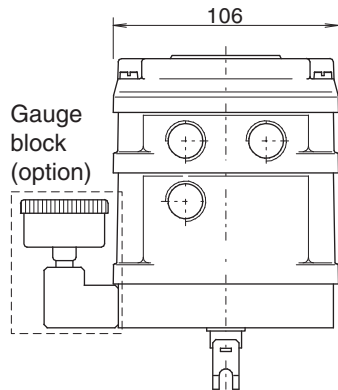

Description

This positioner variation has the addition of two mechanical switches to provide an electrical indication at the end of stroke positions.

The switches are operated by two cams on an extension of the positioner indicator spindle and all mechanical parts are contained within the enclosure. Both switches are independently adjustable throughout the operating stroke, but are normally set to indicate at about 5° before each end position.

All three terminals of both switches are pre-wired to terminal blocks which are easily accessible when the positioner cover is removed. Two electrical entries are provided, one of which is fitted with a blanking plug.

S2 switch modules may be added to standard Posiflex F10 or F20 positioners and are available as kit or factory options.

Construction

The S2 switch module (1) is assembled to the basic positioner by inserting it between the base housing and the cover. The positioner spindle provides the drive for the switch cams (3).

Control options are stackable and fully modular so that combinations of position transmitters and switch modules can be assembled as required.

Specification

Switches:

- Type : V3
- Voltage : 250 V AC / V DC
- Current : 11 A - 250 V AC
- : 1 A - 12 V DC
- : 250mA - 250V DC

- Contacts : Single pole, change over - Normally open and normally closed
- Entries : 2x M20x1.5 (option, 1/2" NPT)
- Temperature : -20° C to +80° C
- Housing : Aluminium Alloy
- Finish : Polyester powder coated
- Enclosure : IP65

Identification

- Factory option : Add '+S2' to the basic positioner number, ie. F10+S2
- Kit option : S2