

Hytork XL Series

Technical Data Pneumatic Rack and Pinion Actuators

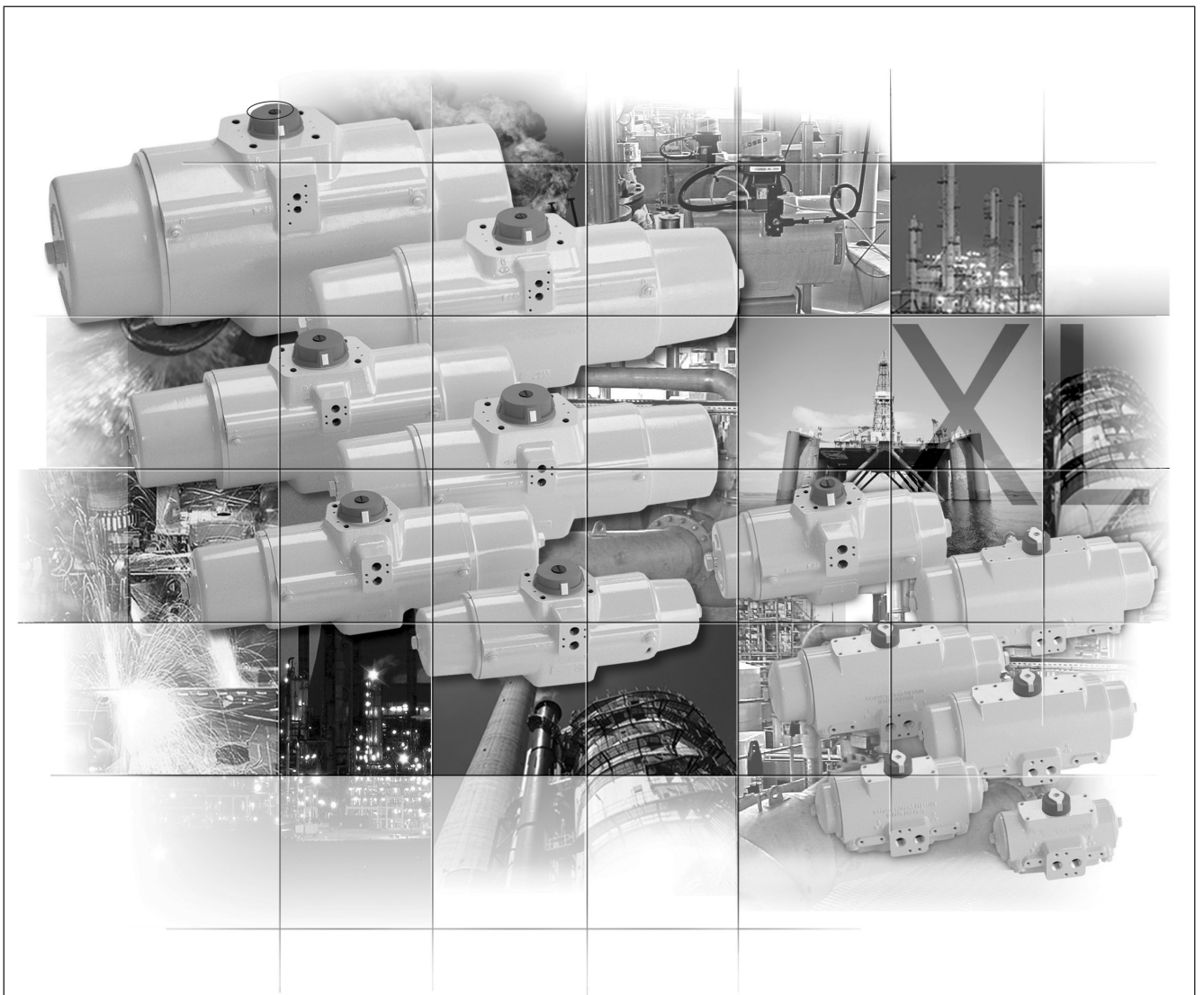

HYTORK™

EMERSON™

Copyright © Emerson. The information in this document is subject to change without notice. Updated data sheets can be obtained from our website www.emerson.com/eim or from your Emerson Automation Solutions - Actuation Technologies Center:

America's: +1 281 477 4100 Europe: +36 22 53 0950 Asia/Pacific: +65 67 77 8211

Torque Data

Spring Return Actuators (Nm), XL26 to XL681

Model Number	Spring Rating	Torque from Springs		Torques from air stroke (Nm) at given operating air pressure (bar)													
				3.0 bar(g)		4.0 bar(g)		5.0 bar(g)		5.5 bar(g)		6.0 bar(g)		7.0 bar(g)		8.0 bar(g)	
		Start	End	Start	End	Start	End	Start	End	Start	End	Start	End	Start	End	Start	End
XL26	S40	6	4	7	4	10	8	14	11	15	13	17	15	21	18	24	22
	S50	7	4	6	3	9	6	13	10	14	12	16	13	20	17	23	20
	S60	9	5	5	1	8	5	12	8	14	10	15	12	19	15	22	19
	S70	10	6	-	-	8	3	11	7	13	9	14	10	18	14	21	17
	S80	12	7	-	-	7	2	10	5	12	7	14	9	17	12	20	16
	S90	13	8	-	-	-	-	9	4	11	6	13	7	16	11	20	14
S1C	15	9	-	-	-	-	8	2	10	4	12	6	15	9	19	13	
XL71	S40	15	9	17	11	26	20	34	28	38	32	43	37	51	45	60	54
	S50	19	11	15	7	23	16	32	24	36	29	41	33	49	42	58	50
	S60	22	13	12	4	21	12	30	21	34	25	38	29	47	38	55	47
	S70	26	16	-	-	19	8	27	17	32	21	36	26	45	34	53	43
	S80	30	18	-	-	17	5	25	13	30	18	34	22	42	31	51	39
	S90	33	20	-	-	-	-	23	10	27	14	32	18	40	27	49	35
S1C	37	22	-	-	-	-	21	6	25	10	29	15	38	23	47	32	
XL131	S40	28	17	32	21	48	37	64	53	72	61	80	69	97	85	113	102
	S50	35	21	28	14	44	30	60	46	68	54	76	62	92	78	109	95
	S60	42	25	23	7	40	23	56	39	64	47	72	55	88	71	104	88
	S70	49	29	-	-	35	16	52	32	60	40	68	48	84	64	100	81
	S80	56	33	-	-	31	9	47	25	56	33	64	41	80	57	96	74
	S90	63	38	-	-	-	-	43	18	51	26	59	34	76	51	92	67
S1C	70	42	-	-	-	-	39	11	47	19	55	27	71	44	88	60	
XL186	S40	37	22	43	28	65	50	86	71	97	82	108	93	130	115	152	137
	S50	47	28	37	19	59	40	81	62	92	73	103	84	124	106	146	127
	S60	56	34	32	9	53	31	75	53	86	64	97	75	119	96	140	118
	S70	65	39	-	-	48	22	70	43	80	54	91	65	113	87	135	109
	S80	75	45	-	-	42	12	64	34	75	45	86	56	108	78	129	99
	S90	84	50	-	-	-	-	58	25	69	36	80	47	102	68	124	90
S1C	93	56	-	-	-	-	53	15	64	26	75	37	96	59	118	81	
XL221	S40	52	31	60	39	90	69	120	99	135	114	151	130	181	160	211	190
	S50	65	39	52	26	82	56	112	86	128	101	143	117	173	147	203	177
	S60	78	47	44	13	74	43	105	73	120	88	135	104	165	134	196	164
	S70	91	55	-	-	66	30	97	60	112	75	127	90	157	121	188	151
	S80	105	63	-	-	59	17	89	47	104	62	119	77	150	108	180	138
	S90	118	71	-	-	-	-	81	34	96	49	111	64	142	95	172	125
S1C	131	78	-	-	-	-	73	21	88	36	104	51	134	82	164	112	
XL281	S40	64	37	71	45	108	81	144	117	162	135	180	154	216	190	253	226
	S50	80	47	62	29	98	65	135	101	153	119	171	138	207	174	243	210
	S60	96	56	-	-	89	49	125	85	143	103	161	122	198	158	234	194
	S70	112	66	-	-	80	33	116	69	134	87	152	106	188	142	225	178
	S80	128	75	-	-	-	-	106	53	125	71	143	90	179	126	215	162
	S90	144	84	-	-	-	-	97	37	115	55	133	74	170	110	206	146
S1C	160	94	-	-	-	-	-	-	106	39	124	57	160	94	197	130	
XL426	S40	94	56	102	65	155	118	208	171	235	197	261	223	314	276	367	329
	S50	117	70	88	41	141	94	194	147	221	174	247	200	300	253	353	306
	S60	141	84	-	-	127	71	180	124	206	150	233	177	286	229	339	282
	S70	164	99	-	-	113	47	166	100	192	127	219	153	272	206	325	259
	S80	188	113	-	-	-	-	152	77	178	103	205	130	258	182	311	235
	S90	211	127	-	-	-	-	138	53	164	80	191	106	244	159	296	212
S1C	235	141	-	-	-	-	-	-	150	56	177	83	229	136	282	188	
XL681	S40	151	91	168	108	254	194	340	280	384	323	427	366	513	453	599	539
	S50	189	113	145	70	232	156	318	242	361	285	404	329	490	415	576	501
	S60	227	136	123	32	209	118	295	205	338	248	381	291	468	377	554	463
	S70	264	159	-	-	186	81	273	167	316	210	359	253	445	339	531	425
	S80	302	181	-	-	164	43	250	129	293	172	336	215	422	301	509	388
	S90	340	204	-	-	-	-	227	91	270	134	313	178	400	264	486	350
S1C	378	227	-	-	-	-	205	54	248	97	291	140	377	226	463	312	

Note:
We recommend that the valve manufacturer supply the maximum required torque values (including any adjustments or suggested safety factors for valve service conditions or application). Additionally, the valve manufacturer must identify at which position(s) and direction(s) of rotation (Counter Clock Wise or Clock Wise) these maximum requirements occur.

S1C Spring Return
For all fail closed butterfly valves and other spring return applications where 7 bar air is available, Hytorc's optional S1C Spring Modules will often permit the selection of a smaller Hytorc Actuator. Both space and cost savings can be achieved.

Torque Data

Spring Return Actuators (Nm), XL1127 to XL4581

Model Number	Spring Rating	Torque from Springs		Torques from air stroke (Nm) at given operating air pressure (bar)													
		Start	End	3.0		4.0		5.0		5.5		6.0		7.0		8.0	
				Start	End	Start	End	Start	End	Start	End	Start	End	Start	End	Start	End
XL1127	S40	247	148	285	186	429	330	574	474	646	547	718	619	862	763	1007	907
	S50	309	185	248	124	392	268	536	413	609	485	681	557	825	701	970	846
	S60	371	222	211	62	355	206	499	351	572	423	644	495	788	639	932	784
	S70	433	259	-	-	318	145	462	289	535	361	607	433	751	578	895	722
	S80	495	296	-	-	281	83	425	227	497	299	570	371	714	516	858	660
	S90	556	334	-	-	-	-	388	165	460	237	533	310	677	454	821	598
S1C	618	371	-	-	-	-	351	103	423	176	495	248	640	392	784	537	
XL1372	S40	304	183	346	225	523	401	699	577	787	665	875	753	1052	930	1228	1106
	S50	381	228	301	148	477	325	653	501	741	589	830	677	1006	854	1182	1030
	S60	457	274	255	72	431	249	608	425	696	513	784	601	960	778	1137	954
	S70	533	320	-	-	386	172	562	349	650	437	738	525	915	701	1091	878
	S80	609	365	-	-	340	96	516	273	605	361	693	449	869	625	1045	802
	S90	685	411	-	-	-	-	471	197	559	285	647	373	823	549	1000	726
S1C	761	456	-	-	-	-	425	120	513	209	601	297	778	473	954	649	
XL2586	S40	574	345	654	425	987	758	1320	1091	1487	1257	1654	1424	1987	1757	2320	2090
	S50	718	431	568	281	901	614	1234	947	1401	1114	1567	1280	1900	1613	2233	1946
	S60	862	517	482	137	815	470	1148	803	1315	970	1481	1137	1814	1470	2147	1803
	S70	1005	603	-	-	729	327	1062	660	1228	826	1395	993	1728	1326	2061	1659
	S80	1149	689	-	-	643	183	976	516	1142	683	1309	849	1642	1182	1975	1515
	S90	1293	776	-	-	-	-	890	373	1056	539	1223	706	1556	1039	1889	1372
S1C	1436	862	-	-	-	-	803	229	970	396	1136	562	1470	895	1803	1228	
XL4581	S40	1017	610	1153	747	1741	1334	2329	1922	2623	2216	2916	2510	3504	3097	4092	3685
	S50	1271	762	1001	492	1588	1080	2176	1668	2470	1962	2764	2256	3352	2843	3939	3431
	S60	1525	915	848	238	1436	826	2024	1414	2318	1708	2611	2001	3199	2589	3787	3177
	S70	1779	1067	-	-	1284	572	1871	1160	2165	1453	2459	1747	3047	2335	3634	2923
	S80	2033	1220	-	-	1131	318	1719	905	2013	1199	2306	1493	2894	2081	3482	2669
	S90	2287	1372	-	-	-	-	1566	651	1860	945	2154	1239	2742	1827	3329	2414
S1C	2541	1525	-	-	-	-	1414	397	1708	691	2001	985	2589	1573	3177	2160	

Note:

We recommend that the valve manufacturer supply the maximum required torque values (Including any adjustments or suggested safety factors for valve service conditions or application). Additionally, the valve manufacturer must identify at which position(s) and direction(s) of rotation (Counter Clock Wise or Clock Wise) these maximum requirements occur.

S1C Spring Return

For all fail closed butterfly valves and other spring return applications where 100 Psi air is available, Hytorc's optional S1C Spring Modules will often permit the selection of a smaller Hytorc Actuator. Both space and cost savings can be achieved

Torque Data

Double Acting Actuators (Nm)

Actuator Model	Torques in (Nm.) at given operating air pressure (bar)						
	3.0 bar(g)	4.0 bar(g)	5.0 bar(g)	5.5 bar(g)	6.0 bar(g)	7.0 bar(g)	8.0 bar(g)
XL26 DA	10	14	17	19	21	24	28
XL71 DA	26	34	43	47	52	60	69
XL131 DA	49	65	81	89	97	113	129
XL186 DA	65	87	109	120	131	152	174
XL221 DA	91	121	152	167	182	212	243
XL281 DA	109	145	181	200	218	254	290
XL426 DA	159	212	264	291	317	370	423
XL681 DA	259	345	431	474	517	604	690
XL1127 DA	433	577	722	794	866	1010	1155
XL1372 DA	529	705	882	970	1058	1234	1411
XL2586 DA	999	1332	1665	1832	1998	2331	2664
XL4581 DA	1763	2351	2939	3232	3526	4114	4702

Note:

We recommends that the valve manufacturer supply the maximum required torque values (Including any adjustments or suggested safety factors for valve service conditions or application). Additionally, the valve manufacturer must identify at which position(s) and direction(s) of rotation (Counter Clock Wise or Clock Wise) these maximum requirements occur.

Envelope Dimensions

XL26 - XL4581 Metric Actuators

XL26 to XL221

Spring Return and Double acting Actuators

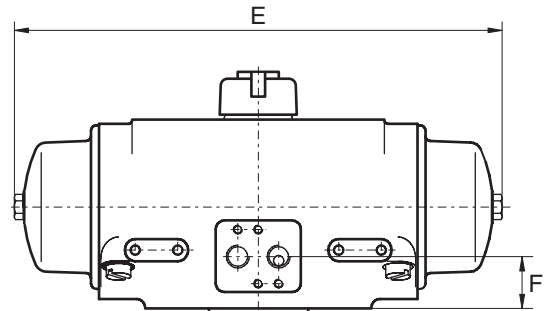
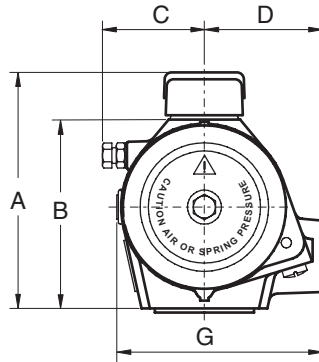

XL281 to XL4581

Spring Return Actuators

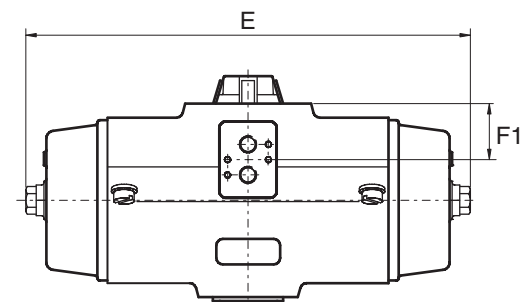
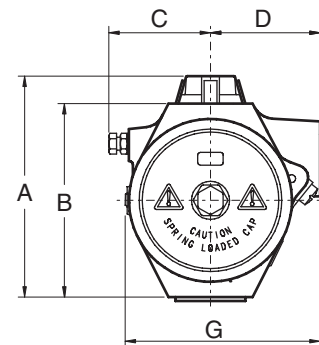

XL281 to XL4581

Double Acting Actuators

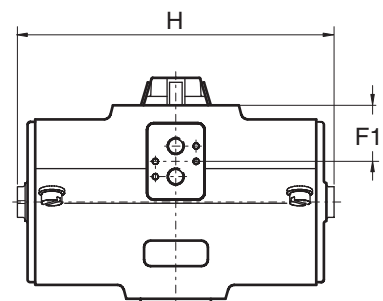
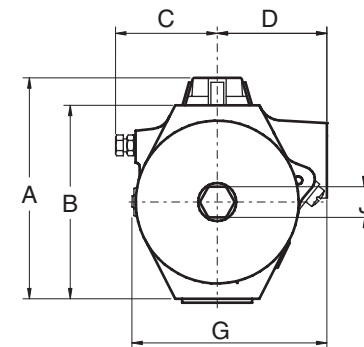

Dim. in mm.	Models											
	XL26	XL71	XL131	XL186	XL221	XL281	XL426	XL681	XL1127	XL1372	XL2586	XL4581
A	104.5	122.4	138.4	144	160	176	169	204	234	249	294	390
B	77	95	111	117	133	152	147	180	200	215	260	356
C	45	57	64	71	78	87	86	95	116	124	-/-	-/-
D	52	60	70	72	81	86	88	96	108	116	131	160
E	165	222	293	332	350	348	462	582	664	716	862	886
F	29	29	30	30	33	-/-	-/-	-/-	-/-	-/-	-/-	-/-
F1	-/-	-/-	-/-	-/-	-/-	44	42	52	56	50	49	76
G	86	103	122	126	142	153	157	175	199	216	254	321
H	-/-	-/-	-/-	-/-	-/-	257	310	343	396	407	476	515
J	-/-	-/-	-/-	-/-	-/-	24	36	36	36	36	36	36

Product Data sheet

D85 Rev. 0
October 2017

Hytorc XL

Standard Drive & Bottom Mounting Details

XL26 - XL4581 Metric Actuators

Basic Bottom Mounting Details

Model	ISO	A	B ± 0.25	C ± 0.25	D	E ± 0.25
XL 26	F05	M6	9.0	50.0	M6	9.0
XL 71	F07	M8	12.0	70.0	M8	12.0
XL 131	F07	M8	12.0	70.0	M8	12.0
XL 186	F07	M8	12.0	70.0	M8	12.0
XL 221	F07	M8	12.0	70.0	M8	12.0

Model	F ± 0.175	G ± 0.15	H ± 0.175	$\emptyset J$	$\emptyset K$
XL 26	35.35	90.0	35.35	27.8	34.97/34.94
XL 71	49.5	114.0	49.5	46.0	54.97/54.92
XL 131	49.5	114.0	49.5	46.0	54.97/54.92
XL 186	49.5	114.0	49.5	46.0	54.97/54.92
XL 221	49.5	114.0	49.5	46.0	54.97/54.92

Models shown with optional Centering Ring fitted

Additional Bottom Mounting Details

Model	ISO	A	B ± 0.25	C ± 0.25	D ± 0.175
XL 26	F03	M5	8.0	36.0	25.46
XL 71	F05	M6	9.0	50.0	35.35
XL 131	F05	M6	9.0	50.0	35.35

Models shown with optional Centering Ring removed to reveal additional ISO mounting holes.

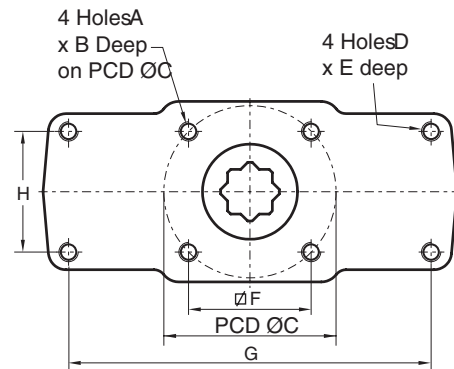

Note:
- Dimensions in mm
- Valve flange and drive according to ISO5211

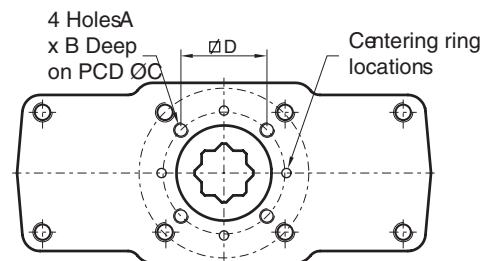

Basic Bottom Mounting Details

Model	ISO	A	B ± 0.25	C ± 0.25	D ± 0.175	$\emptyset E$	$\emptyset F$	G
XL 281	F07	M8	12.0	70.0	49.5	54.97/54.92	45.0	3.0
XL 426	F10	M10	15.0	102.0	72.1	69.97/69.92	65.0	3.0
XL 681	F10	M10	15.0	102.0	72.1	69.97/69.92	65.0	3.0
XL 1127	F12	M12	18.0	125.0	88.4	84.96/84.91	75.0	3.0
XL 1372	F12	M12	18.0	125.0	88.4	84.96/84.91	75.0	3.0
XL 2586	F16	M20	20.0	165.0	116.7	129.95/129.89	115.0	5.0
XL 4581	F16	M20	25.0	165.0	116.7	129.95/129.89	115.0	5.0

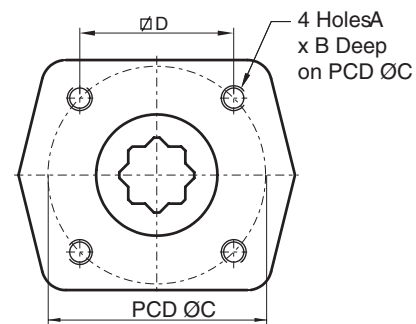

Standard Drive Details

Model	ISO	A ± 0.1	B	C	D ± 0.5	E	F ± 0.5
XL 26	F05	18.1	28.0	14.7	13.85	14.00/14.11	2.4
XL 71	F07	22.2	45.0	17.9	16.85	17.00/17.11	2.4
XL 131	F07	22.2	45.0	17.9	16.85	17.00/17.11	2.4
XL 186	F07	22.2	45.0	17.9	16.85	17.00/17.11	2.4
XL 221	F07	22.2	45.0	17.9	16.85	17.00/17.11	2.4
XL 281	F07	22.2	45.0	17.9	16.85	17.00/17.11	2.4
XL 426	F10	28.2	60.0	23.1	24.5	22.00/22.13	30.5
XL 681	F10	28.2	60.0	23.1	24.5	22.00/22.13	30.5
XL 1127	F12	36.2	72.0	28.4	29.5	27.00/27.13	25.5
XL 1372	F12	36.2	72.0	28.4	29.5	27.00/27.13	25.5
XL 2586	F16	60.2	100.0	48.5	48.5	46.00/46.16	35.5
XL 4581	F16	60.2	100.0	48.5	48.5	46.00/46.16	35.5

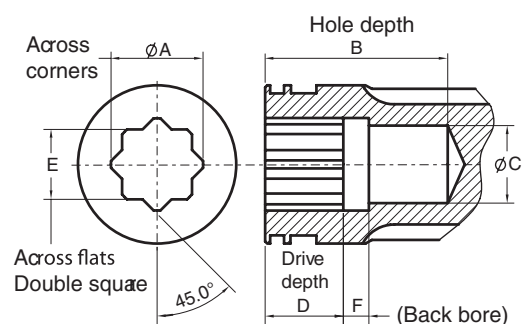

HYTORK™

EMERSON™

Top and Solenoid Mounting Details

XL26 - XL4581 Metric Actuators

Pinion top details

Model	ØA	ØB	C	D	E
XL 26	24.6/24.5	16.6/16.5	14.00/13.85	20.1/19.9	16.4/16.0
XL 71	24.6/24.5	16.6/16.5	14.00/13.85	20.1/19.9	16.4/16.0
XL 131	24.6/24.5	16.6/16.5	14.00/13.85	20.1/19.9	16.4/16.0
XL 186	30.5/30.0	16.6/16.5	14.00/13.85	20.1/19.9	13.7/13.3
XL 221	30.5/30.0	16.6/16.5	14.00/13.85	20.1/19.9	13.7/13.3
XL 281	44.5/44.0	23.5/23.3	17.00/16.85	20.1/19.9	12.6/12.4
XL 426	64.5/64.0	43.5/43.3	22.00/21.85	20.1/19.9	12.6/12.4
XL 681	69.5/69.0	43.5/43.3	22.00/21.85	20.1/19.9	12.6/12.4
XL 1127	90.5/90.0	67.1/66.9	36.00/35.85	30.1/29.9	18.1/17.9
XL 1372	90.5/90.0	67.1/66.9	36.00/35.85	30.1/29.9	18.1/17.9
XL 2586	95.5/95.0	71.5/71.3	40.00/39.85	30.1/29.9	18.1/17.9
XL 4581	95.5/95.0	71.5/71.3	40.00/39.85	30.1/29.9	18.1/17.9

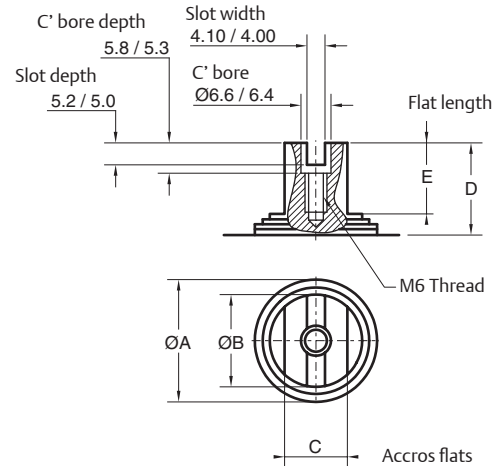

VDI / VDE Top Mounting details

XL 26 - XL221

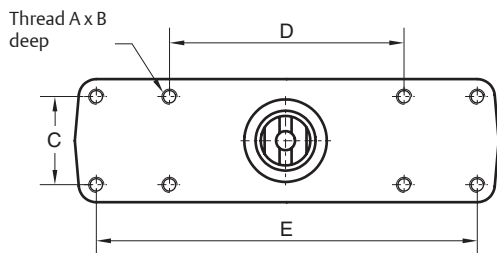

XL 281 - XL4581

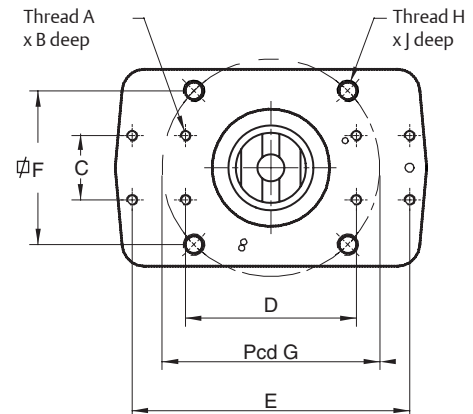

Model	A	B	C	D	E	ISO	F	H	J	G
XL 26	M5	6.25	30.0	80.0	-	-/-	-/-	-/-	-/-	-/-
XL 71	M5	6.25	30.0	80.0	-	-/-	-/-	-/-	-/-	-/-
XL 131	M5	6.25	30.0	80.0	130.0	-/-	-/-	-/-	-/-	-/-
XL 186	M5	6.25	30.0	80.0	130.0	-/-	-/-	-/-	-/-	-/-
XL 221	M5	6.25	30.0	80.0	130.0	-/-	-/-	-/-	-/-	-/-
XL 281	M5	8.0	30.0	80.0	130.0	F07	49.5	M8	12	70
XL 426	M5	8.0	30.0	80.0	130.0	F10	72.1	M10	15	102
XL 681	M5	8.0	30.0	80.0	130.0	F10	72.1	M10	15	102
XL 1127	M5	8.0	30.0	130.0	-	F12	88.4	M12	18	125
XL 1372	M5	8.0	30.0	130.0	-	F12	88.4	M12	18	125
XL 2586	M5	8.0	30.0	130.0	-	F16	116.7	M20	20	165
XL 4581	M5	8.0	30.0	130.0	-	F16	116.7	M20	20	165

Product Data sheet

D86 Rev 0 Page 2 of 2
October 2017

Hytork XL

NAMUR Solenoid Mounting details

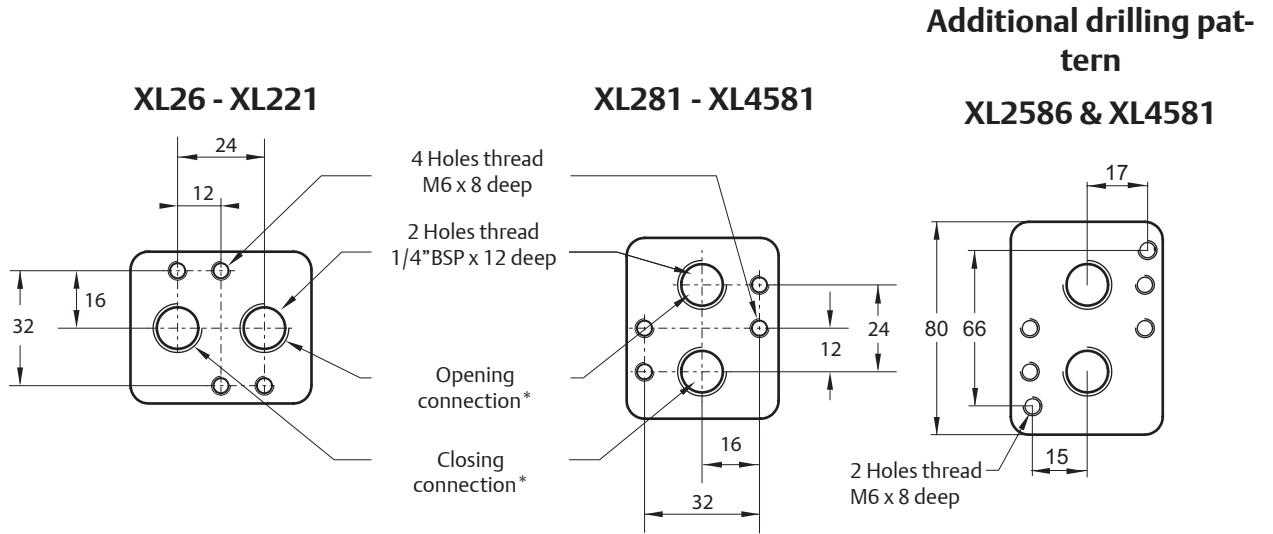

Note:

* "Opening" or "Closing" port operation, as shown, is for standard (Spring-to-Close) actuators. For reverse acting actuators (Spring-to-Open) the port operation is also reversed.

Additional Front mounting patterns

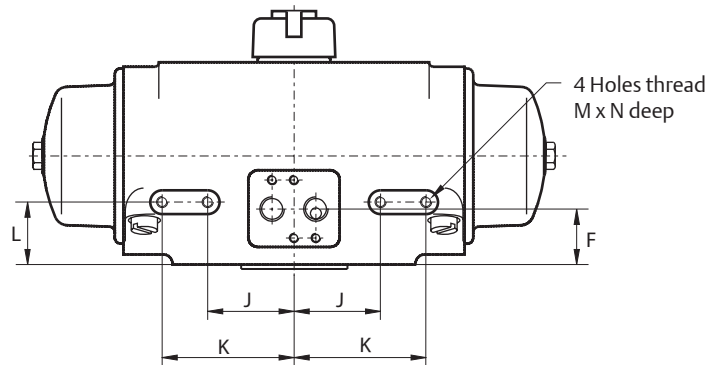

Model	F	J	K	L	M	N
XL26	29	31	46	32	M5	6.5
XL71	29	33.7	58.7	32	M5	6.5
XL131	30	47.3	72.3	34	M6	6.5
XL186	30	61.3	86.3	34	M6	6.5
XL221	33	62.5	87.5	37	M6	6.5

HYTORK™

EMERSON™

Spring return actuator with High Flow Plate

Increase the cycle speed of spring return actuators

Description:

The High Flow Plate is a simple means to increase the cycle speed (and reduce the cycle time) on single acting (spring return) pneumatic actuators.

Cycle speed:

In general pneumatic rack & pinion actuators are equipped with large internal air porting that allows adequate cycling under normal circumstances.

On the other hand, the 1/4" solenoid valves or pneumatic fitting materials, limit the maximum speed potential of the actuator due to the orifice diameter. Under normal operation conditions, the achieved cycle speed is sufficient.

If faster cycle times are required (<0.5 or <1 seconds) 1/4" solenoid valves or pneumatic fitting material can become a problem. These components will, in this case, function as a throttle, reducing the potential maximum air flow and as such the maximum cycle speed.

The High Flow Plate solves this problem. High Flow plates can be supplied with 1/2" air connections to allow the fitting of larger solenoid valves and pneumatic fitting material.

Construction:

The High Flow Plate is a aluminum plate which can be mounted directly to solenoid interface on actuators which are designed according VDI/VDE 3845 (NAMUR). The plate is supplied with fasteners and seals.

The customer side of the plate is equipped with 1/2" or 3/4" NPT or BSP air connections for piped solenoid control.

Specifications:

Materials:

- 1 Block: Aluminium alloy, black anodized (10-15µm)
- 2 Fasteners: Stainless steel
- 3 O-ring seals: NBR Rubber

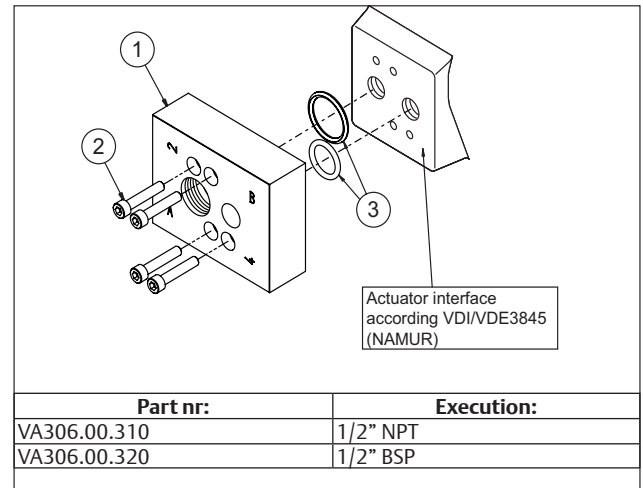

Note:

- 1 The High Flow Plate on its own does not make the cycle time of an actuator quicker. Take care that there is sufficient air supply capacity at actuator:
 - Air supply capacity must be larger than the Cv or Kv value of the control solenoid valve.
 - Use tubing with sufficient large diameter.
 - Make tubing from the main air supply to the actuator as short as possible.
- 2 For the largest size actuators enlarging the port to the central air chamber to 1/2" can be considered to achieve the required cycle speed.
- 3 Consider the use of Quick Exhaust valves in combination with these High Flow Plates.
- 4 In general the actuators life cycle is reduced when cycling very fast.
 - For valves that cycle not that often, the total life cycle will still be sufficient.
 - For applications with increased cycle speed, that do cycle often, external limit stops (bottom stop plate) are recommended, especially on the larger size actuators.

Please consult your nearest HYTORK representative for more detailed information.

Product Data sheet

D190 Rev 0 Page 2 of 2
October 2017

Hytork XL

Dimensions:

Dimension	1/2"	
in:	mm	Inch
A	63.5	2.50
B	82	3.23
C	25.4	1.00
D	32	1.26
E	25	0.98
F	16	0.63
G	29	1.14
H	12	0.47
J	27	1.06
K	1.27	0.05
L	1/2"BSP	1/2"NPT
M	1/4"BSP	1/4"NPT

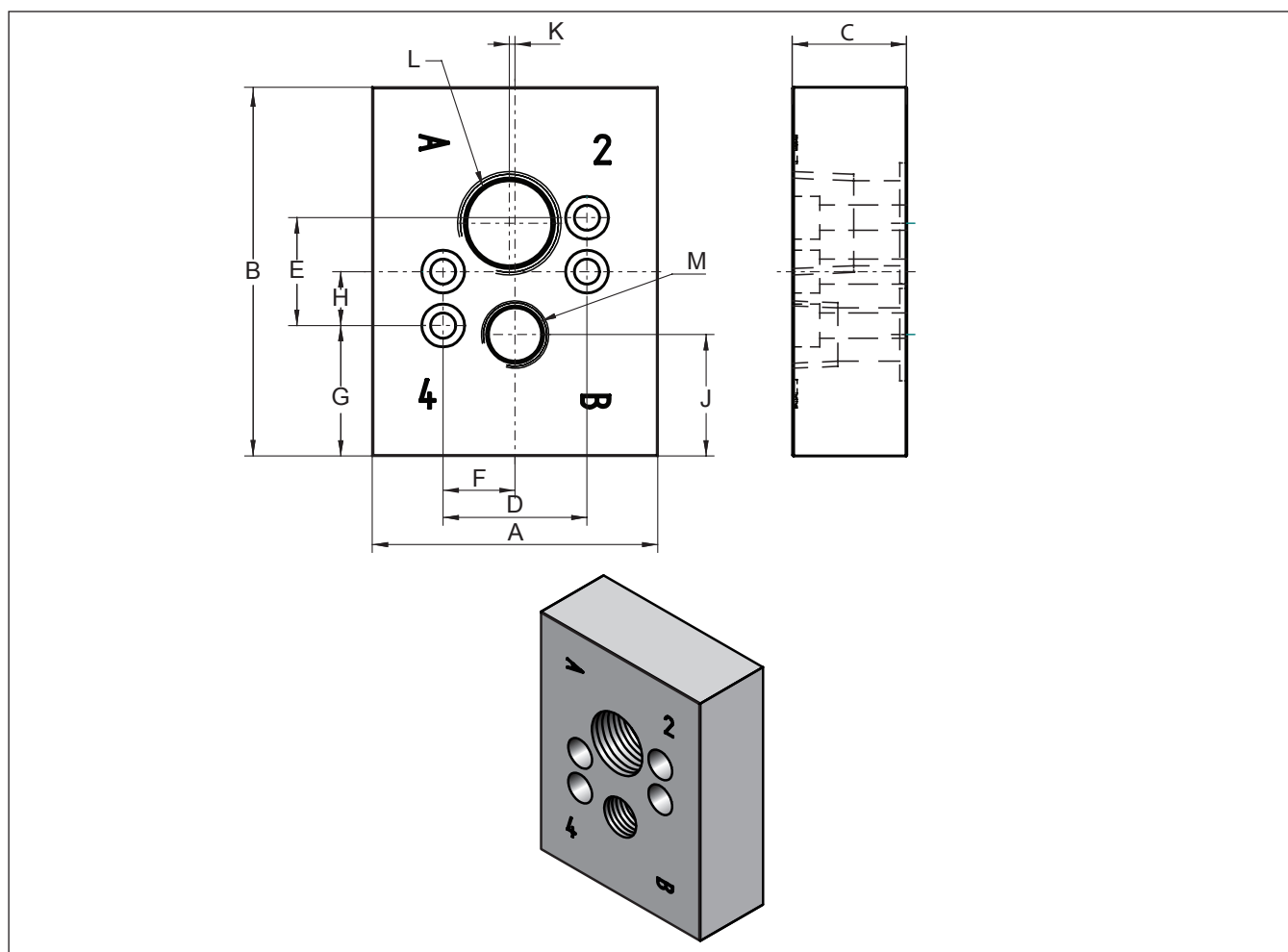

HYTORK™

EMERSON™

Copyright © Emerson. The information in this document is subject to change without notice. Updated data sheets can be obtained from our website www.emerson.com/eim or from your Emerson Automation Solutions - Actuation Technologies Center:
America's: +1 281 477 4100 Europe: +36 22 53 0950 Asia/Pacific: +65 67 77 8211

Envelope Dimensions

XL2586 / XL4581 Actuators with Stop Blocks (Metric)

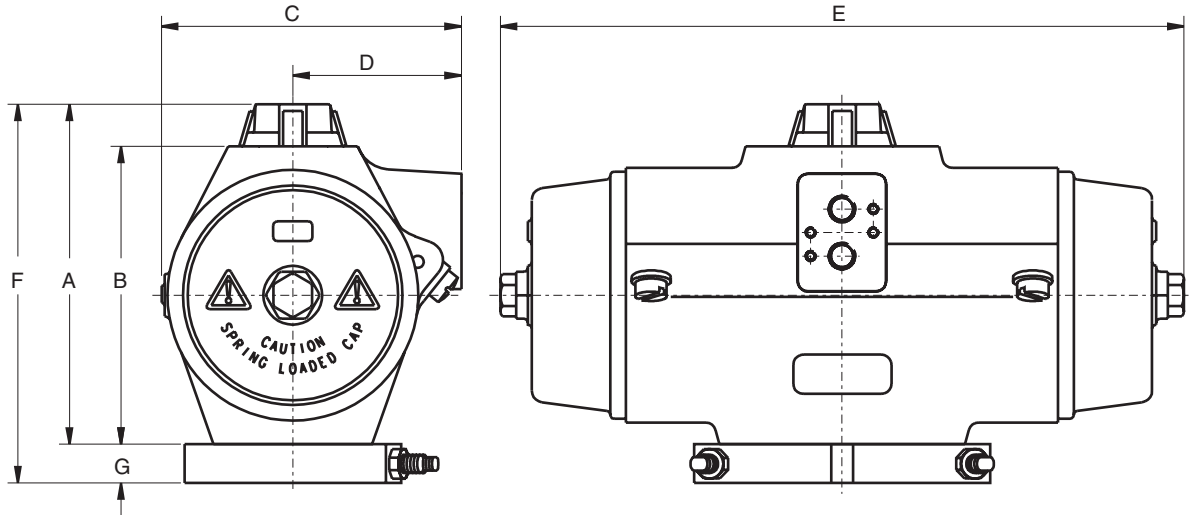

Spring Return Units

Models	A	B	C	D	E	F	G	Weight (kg)	
								Block	Assembly
XL2586	292.0	260.0	253.0	131.0	862.0	338.0	46.0	9.5	88.5
XL4581	388.0	356.0	321.0	160.0	884.0	434.0	46.0	9.5	151.5

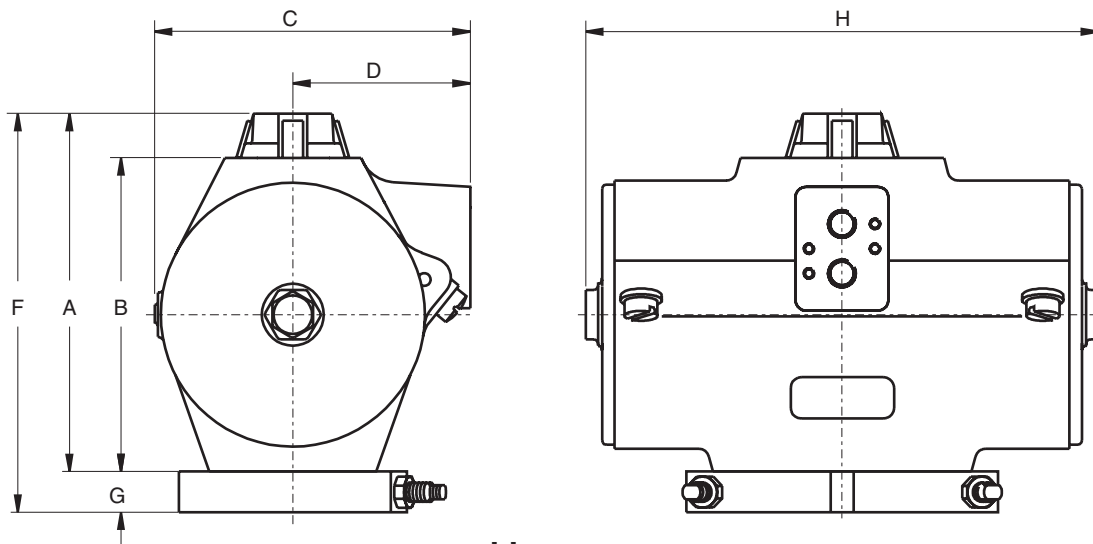

Double Acting Units

Models	A	B	C	D	H	F	G	Weight (kg)	
								Block	Assembly
XL2586	292.0	260.0	253.0	131.0	467.0	337.0	46.0	9.5	55.5
XL4581	388.0	356.0	321.0	160.0	515.0	433.0	46.0	9.5	92.5

Air Consumption

XL26 to XL4581 (Metric Data)

Actuator Model	Consumption per stroke (cm ³)						
	Pressure in Barg / Outward stroke						
	3	4	5	5.5	6	7	8
XL26	317	402	487	530	573	658	744
XL71	797	1012	1228	1335	1443	1658	1874
XL131	1529	1942	2356	2563	2769	3183	3596
XL186	2031	2581	3132	3407	3682	4232	4782
XL221	2744	3491	4239	4612	4986	5733	6481
XL281	3621	4618	5615	6113	6612	7608	8605
XL426	5076	6452	7828	8516	9203	10579	11955
XL681	7969	10118	12266	13340	14414	16562	18710
XL1127	13391	17009	20627	22436	24245	27863	31481
XL1372	16123	20473	24823	26998	29173	33523	37873
XL2586	28947	36662	44378	48236	52093	59809	67524
XL4581	51773	65609	79446	86364	93283	107119	120956

Actuator Model	Consumption per stroke (cm ³)						
	Pressure in Barg / Inward stroke						
	3	4	5	5.5	6	7	8
XL26	455	586	717	783	849	980	1112
XL71	1226	1584	1943	2122	2301	2659	3018
XL131	2465	3190	3916	4279	4641	5367	6092
XL186	3222	4169	5117	5590	6064	7011	7958
XL221	4391	5687	6984	7632	8280	9576	10873
XL281	5502	7126	8750	9562	10374	11997	13621
XL426	8145	10544	12943	14142	15341	17740	20139
XL681	14767	19182	23596	25803	28010	32424	36838
XL1127	12875	16321	19767	21490	23213	26659	30105
XL1372	15469	19601	23733	25799	27865	31997	36129
XL2586	27756	35074	42393	46052	49711	57030	64348
XL4581	50867	64401	77936	84703	91471	105005	118540

OUTWARD STROKE on
Spring return and
Double acting actuators

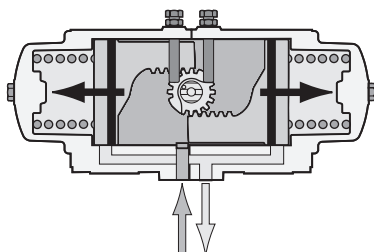

INWARD STROKE on
Double acting actuators

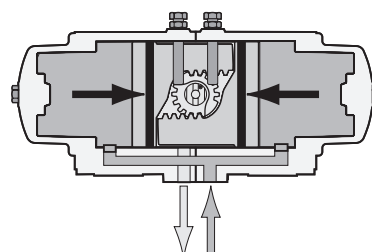

Free Air Volume at Atmospheric Pressure

XL26 to XL4581 Metric Data

Actuator Model	Double & Single Acting		
	Central Chamber Volumes (cm3)		
	Open	Closed	Displaced
XL26	85	25	60
XL71	215	65	150
XL131	413	125	288
XL186	550	170	380
XL221	747	245	502
XL281	997	367	630
XL426	1376	427	949
XL681	2148	623	1525
XL1127	3618	1081	2537
XL1372	4350	1277	3073
XL2586	7715	1915	5800
XL4581	13837	3574	10263

Actuator Model	Double Acting ONLY		
	End Cap Chamber Volumes (cm3)		
	Open	Closed	Displaced
XL26	71	131	60
XL71	208	358	150
XL131	437	725	288
XL186	567	947	380
XL221	794	1296	502
XL281	994	1624	630
XL426	1450	2399	949
XL681	2889	4414	1525
XL1127	909	3446	2537
XL1372	1059	4132	3073
XL2586	1518	7318	5800
XL4581	3272	13535	10263

Spring Return and Double Acting Actuators

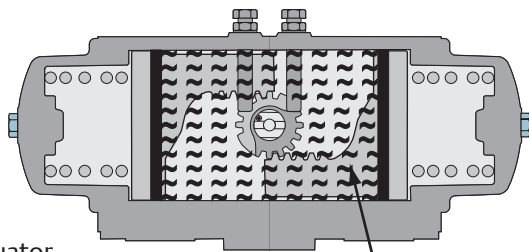

Actuator Open

Air in Central Chamber

Actuator Closed

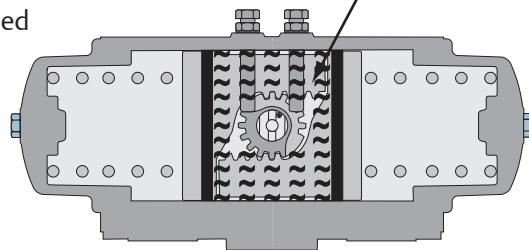

Double Acting Actuators

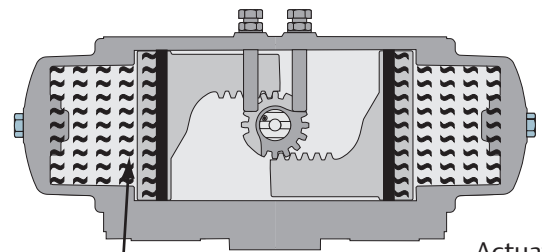

Actuator Open

Air in End Chambers

Actuator Closed

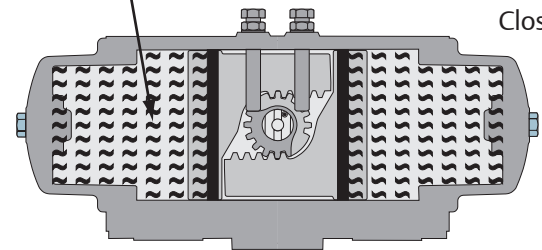

Product Data sheet

D108 Rev. 0
October 2017

Hytork XL

Materials of Construction

XL Series Actuators (European Terminology)

Component Description	Material	Qty	Model Numbers
Body	Aluminium, Ceramigard Treated and Polyester Powder Coated	1	XL26 - XL4581
End Cap	Aluminium, Electrophoretic Coated and Polyester Powder Coated	2	XL26 - XL4581
Piston	Aluminium	2	XL26 - XL4581
*Retractor Cap	Steel , Zinc Plated	2	XL1127, 4581
Thread Insert (Piston)	Steel , Zinc Plated	2	XL26 - XL681
Pinion	Steel , Cobalt Zinc Plated	1	XL26 - XL4581
*Springs	Spring Steel , Electrophoretic Coated	2 or 4	XL26 - XL4581
Travel Stop / Locking Nut	Stainless Steel	2	XL26 - XL1372
Thread Seal	Stainless Steel / Rubber	2	XL26 - XL221
Washer	Stainless Steel	2	XL281 - XL1372
Circlip	Spring Steel , Zinc Plated	1	XL26 - XL4581
Steel Thrust Washer	Stainless Steel	1	XL26 - XL221
	Steel , Zinc Plated and Passivated	1	XL281 - XL4581
Thrust Washer	Nylatron (MoS2 filled PA66)	1	XL26 - XL4581
Ball Plug	High Carbon Chromium Steel	2	XL26 - XL4581
SAFEKEY Head	Composite	2	XL26 - XL4581
SAFEKEY Wire	Stainless Steel	2	XL26 - XL4581
Sealing 'O' rings	Nitrile Rubber (Optional - Viton or Silicone)	10	XL26 - XL4581
Bearings (Piston & Pinion)	Acetal M90	6	XL26 - XL4581
Position Indicator	Non-Static Polymer	1	XL26 - XL4581
Location Ring	Acetal M90	1	XL26 - XL4581
Grease	Lithium based (for Nitrile Rubber)		XL26 - XL4581

**Spring Return Models Only*

Temperature range for above mentioned parts : -20°C to +100°C / -4°F to +212°F

Optional temperature ranges:

High temperature range : -20°C to +120°C / -4°F to +248°F (see data sheet D128 for more details)

Low temperature range : -40°C to +100°C / -40°F to +212°F (see data sheet D129 for more details)

HYTORK™

EMERSON™

Actuator Operating Speeds

XL26 to XL4581

Time is shown in seconds

Actuator Model	Operating Pressure = 80 psi (5.5 bar g)			
	Double Acting		Spring Return with S80 Springs	
	Opening Stroke	Closing Stroke	Opening Stroke	Closing Stroke
XL26	0.01	0.01	0.05	0.02
XL71	0.03	0.03	0.09	0.05
XL131	0.03	0.04	0.15	0.09
XL186	0.05	0.06	0.19	0.12
XL221	0.06	0.08	0.24	0.15
XL281	0.20	0.10	0.10	0.20
XL426	0.20	0.30	0.30	0.50
XL681	0.40	0.60	0.40	1.20
XL1127	0.70	0.60	0.50	0.70
XL1372	0.80	0.70	0.70	1.00
XL2586	1.50	1.20	1.20	1.50
XL4581	2.00	2.90	2.20	3.90

Actuator Weights

XL26 to XL4581

Actuator Model	Double Acting		Spring Return with S80 Springs	
	Kg	Lbs	Kg	Lbs
XL26	1.39	3.06	1.53	3.37
XL71	2.39	5.27	2.78	6.13
XL131	3.90	8.60	4.76	10.49
XL186	4.77	10.52	5.45	12.02
XL221	6.19	13.65	7.76	17.11
XL281	7.02	15.47	9.90	21.83
XL426	7.30	16.10	12.50	27.56
XL681	8.80	19.40	22.50	49.60
XL1127	22.00	48.50	36.00	79.37
XL1372	27.00	59.52	46.60	102.73
XL2586	46.00	101.41	79.00	174.16
XL4581	83.00	182.98	142.00	313.05

Spring Ratings and Colour Coding

XL26 to XL4581

Model	Spring Rating														Colour Coding
	S40		S50		S60		S70		S80		S90		S100		
	Left Side	Right Side	Left Side	Right Side	Left Side	Right Side	Left Side	Right Side	Left Side	Right Side	Left Side	Right Side	Left Side	Right Side	
XL26	S20 Outer	S20 Outer	S30 Outer	S20 Outer	S30 Outer	S30 Outer	S20 Outer S20 Inner	S30 Outer	S20 Outer S20 Inner	S20 Outer S20 Inner	S30 Outer S20 Inner	S20 Outer S20 Inner	S30 Outer S20 Inner	S30 Outer S20 Inner	S20 Inner = Green S20 Outer = Pink S30 Outer = Brown
XL71	S20 Outer	S20 Outer	S30 Outer	S20 Outer	S30 Outer	S30 Outer	S20 Outer S20 Inner	S30 Outer	S20 Outer S20 Inner	S20 Outer S20 Inner	S30 Outer S20 Inner	S20 Outer S20 Inner	S30 Outer S20 Inner	S30 Outer S20 Inner	S20 Inner = Green S20 Outer = Pink S30 Outer = Brown
XL131	S20 Outer	S20 Outer	S30 Outer	S20 Outer	S30 Outer	S30 Outer	S20 Outer S20 Inner	S30 Outer	S20 Outer S20 Inner	S20 Outer S20 Inner	S30 Outer S20 Inner	S20 Outer S20 Inner	S30 Outer S20 Inner	S30 Outer S20 Inner	S20 Inner = Green S20 Outer = Pink S30 Outer = Brown
XL186	S20 Outer	S20 Outer	S30 Outer	S20 Outer	S30 Outer	S30 Outer	S20 Outer S20 Inner	S30 Outer	S20 Outer S20 Inner	S20 Outer S20 Inner	S30 Outer S20 Inner	S20 Outer S20 Inner	S30 Outer S20 Inner	S30 Outer S20 Inner	S20 Inner = Green S20 Outer = Pink S30 Outer = Brown
XL221	S20 Outer	S20 Outer	S30 Outer	S20 Outer	S30 Outer	S30 Outer	S20 Outer S20 Inner	S30 Outer	S20 Outer S20 Inner	S20 Outer S20 Inner	S30 Outer S20 Inner	S20 Outer S20 Inner	S30 Outer S20 Inner	S30 Outer S20 Inner	S20 Inner = Green S20 Outer = Pink S30 Outer = Brown
XL281	S20 Outer	S20 Outer	S30 Outer	S20 Outer	S30 Outer	S30 Outer	S20 Outer S20 Inner	S30 Outer	S20 Outer S20 Inner	S20 Outer S20 Inner	S30 Outer S20 Inner	S20 Outer S20 Inner	S30 Outer S20 Inner	S30 Outer S20 Inner	S20 Inner = Green S20 Outer = Pink S30 Outer = Brown
XL426	S20 Outer	S20 Outer	S30 Outer	S20 Outer	S30 Outer	S30 Outer	S20 Outer S20 Inner	S30 Outer	S20 Outer S20 Inner	S20 Outer S20 Inner	S30 Outer S20 Inner	S20 Outer S20 Inner	S30 Outer S20 Inner	S30 Outer S20 Inner	S20 Inner = Green S20 Outer = Pink S30 Outer = Brown
XL681	S20 Outer	S20 Outer	S30 Outer	S20 Outer	S30 Outer	S30 Outer	S20 Outer S20 Inner	S30 Outer	S20 Outer S20 Inner	S20 Outer S20 Inner	S30 Outer S20 Inner	S20 Outer S20 Inner	S30 Outer S20 Inner	S30 Outer S20 Inner	S20 Inner = Green S20 Outer = Pink S30 Outer = Brown
XL1127	S20 Outer	S20 Outer	S30 Outer	S20 Outer	S30 Outer	S30 Outer	S20 Outer S20 Inner	S30 Outer	S20 Outer S20 Inner	S20 Outer S20 Inner	S30 Outer S20 Inner	S20 Outer S20 Inner	S30 Outer S20 Inner	S30 Outer S20 Inner	S20 Inner = Green S20 Outer = Pink S30 Outer = Brown
XL1372	S20 Outer	S20 Outer	S30 Outer	S20 Outer	S30 Outer	S30 Outer	S20 Outer S20 Inner	S30 Outer	S20 Outer S20 Inner	S20 Outer S20 Inner	S30 Outer S20 Inner	S20 Outer S20 Inner	S30 Outer S20 Inner	S30 Outer S20 Inner	S20 Inner = Green S20 Outer = Pink S30 Outer = Brown
XL2586	S20 Outer	S20 Outer	S30 Outer	S20 Outer	S30 Outer	S30 Outer	S20 Outer S20 Inner	S30 Outer	S20 Outer S20 Inner	S20 Outer S20 Inner	S30 Outer S20 Inner	S20 Outer S20 Inner	S30 Outer S20 Inner	S30 Outer S20 Inner	S20 Inner = Green S20 Outer = Pink S30 Outer = Brown
XL4581	S20 Outer	S20 Outer	S30 Outer	S20 Outer	S30 Outer	S30 Outer	S20 Outer S20 Inner	S30 Outer	S20 Outer S20 Inner	S20 Outer S20 Inner	S30 Outer S20 Inner	S20 Outer S20 Inner	S30 Outer S20 Inner	S30 Outer S20 Inner	S20 Inner = Green S20 Outer = Pink S30 Outer = Brown

Spring Identification

Hytorc XL 2 Spring identification

Type	Spring identifier	Color identifier	Dimensions for reference only!			
			Minimum Inner dia.		Free length	
			mm	inch	mm	inch
XL 26	S20 Inner	Green	21	0.81	74 / 71	2.90 / 2.79
	S20 Outer	Pink	29	1.14	74 / 71	2.90 / 2.79
	S30 Outer	Brown	29	1.14	74 / 71	2.90 / 2.79
XL 71	S20 Inner	Green	29	1.12	99 / 95	3.90 / 3.76
	S20 Outer	Pink	40	1.57	99 / 95	3.90 / 3.76
	S30 Outer	Brown	40	1.57	99 / 95	3.90 / 3.76
XL 131	S20 Inner	Green	33	1.30	132 / 127	5.19 / 5.01
	S20 Outer	Pink	47	1.85	132 / 127	5.19 / 5.01
	S30 Outer	Brown	47	1.85	132 / 127	5.19 / 5.01
XL 186	S20 Inner	Green	35	1.38	152 / 146	5.97 / 5.76
	S20 Outer	Pink	52	2.05	152 / 146	5.97 / 5.76
	S30 Outer	Brown	52	2.05	152 / 146	5.97 / 5.76
XL 221	S20 Inner	Green	42	1.63	129 / 154	5.09 / 6.05
	S20 Outer	Pink	58	2.28	129 / 154	5.09 / 6.05
	S30 Outer	Brown	58	2.28	129 / 154	5.09 / 6.05
XL 281	S20 Inner	Green	51	1.99	142 / 148	5.61 / 5.81
	S20 Outer	Pink	71	2.80	142 / 148	5.61 / 5.81
	S30 Outer	Brown	71	2.80	142 / 148	5.61 / 5.81
XL 426	S20 Inner	Green	48	1.87	213 / 218	8.38 / 8.59
	S20 Outer	Pink	69	2.72	213 / 218	8.38 / 8.59
	S30 Outer	Brown	69	2.72	213 / 218	8.38 / 8.59
XL 681	S20 Inner	Green	62	2.44	272 / 277	10.71 / 10.91
	S20 Outer	Pink	83	3.27	272 / 277	10.70 / 10.91
	S30 Outer	Brown	83	3.27	272 / 277	10.70 / 10.91
XL 1127	S20 Inner	Green	74	2.91	303 / 293	11.94 / 11.54
	S20 Outer	Pink	100	3.94	304 / 293	11.95 / 11.53
	S30 Outer	Brown	100	3.94	304 / 294	11.96 / 11.56
XL 1372	S20 Inner	Green	79	3.09	318 / 323	12.52 / 12.72
	S20 Outer	Pink	110	4.33	318 / 323	12.51 / 12.72
	S30 Outer	Brown	110	4.33	318 / 323	12.52 / 12.72
XL 2586	S20 Inner	Green	92	3.62	397 / 403	15.65 / 15.85
	S20 Outer	Pink	138	5.43	397 / 403	15.64 / 15.85
	S30 Outer	Brown	138	5.43	397 / 403	15.65 / 15.85
XL 4581	S20 Inner	Green	140	5.51	402 / 408	15.84 / 16.05
	S20 Outer	Pink	192	7.56	402 / 408	15.84 / 16.05
	S30 Outer	Brown	192	7.56	402 / 408	15.84 / 16.05

Before and After Cross Over Date

XL Actuator Models

XL Range Before June 1999 (11 Models)		
Model	100 PSI / 7 Bar Double Acting Torque	
	inch-pounds	Nm
XL45	321	37
XL70	521	60
XL130	1010	116
XL185	1420	163
XL280	2199	254
XL425	3206	370
XL680	5226	603
XL1125	8750	1010
XL1370	10687	1234
XL2585	20187	2331
XL4580	35625	4114

XL Range After June 1999 (12 Models)		
Model	100 PSI / 7 Bar Double Acting Torque	
	inch-pounds	Nm
XL26	209	24
XL71	522	60
XL131	981	113
XL186	1319	152
XL221	1838	212
XL280	2199	254
XL425	3206	370
XL680	5226	603
XL1125	8750	1010
XL1370	10687	1234
XL2585	20187	2331
XL4580	35625	4114

XL Range After June 2005 (12 Models)		
Model	100 PSI / 7 Bar Double Acting Torque	
	inch-pounds	Nm
XL26	209	24
XL71	522	60
XL131	981	113
XL186	1319	152
XL221	1838	212
XL281	2199	254
XL426	3206	370
XL681	5226	603
XL1126	8750	1010
XL1371	10687	1234
XL2586	20187	2331
XL4581	35625	4114

XL Range After February 2016 (12 Models)		
Model	100 PSI / 7 Bar Double Acting Torque	
	inch-pounds	Nm
XL26	209	24
XL71	522	60
XL131	981	113
XL186	1319	152
XL221	1838	212
XL281	2199	254
XL426	3206	370
XL681	5226	603
XL1127	8750	1010
XL1372	10687	1234
XL2586	20187	2331
XL4581	35625	4114

Product Data sheet

D180 Rev. 0
October 2017

Hytork XL

Actuator Model String Configuration

Hytork XL Actuators

XL 0186 U - S 80 - S CC - Y 0 0

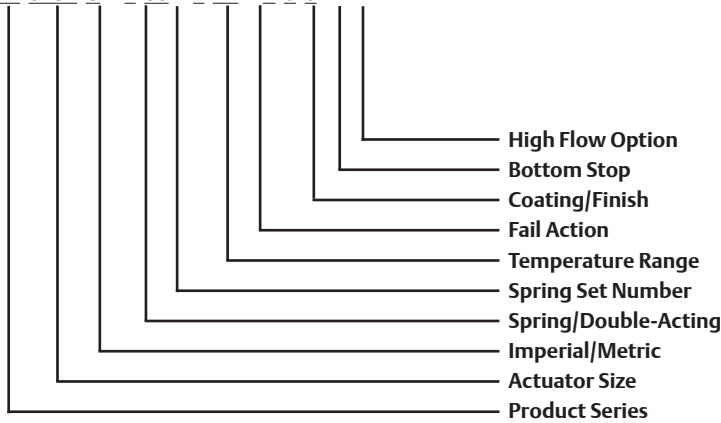

Note:
The options below are all options available. Not all options apply to all configurations.

Actuator Size	
26	Hytork XL 26 Actuator
71	Hytork XL 71 Actuator
131	Hytork XL 131 Actuator
186	Hytork XL 186 Actuator
221	Hytork XL 221 Actuator
281	Hytork XL 281 Actuator
426	Hytork XL 426 Actuator
681	Hytork XL 681 Actuator
1127	Hytork XL 1127 Actuator
1372	Hytork XL 1372 Actuator
2586	Hytork XL 2586 Actuator
4581	Hytork XL 4581 Actuator

Imperial/Metric	
M	Metric actuator (ISO 5211)
U	Imperial actuator (ISO 5211/UNC threaded)

Spring/Double Acting	
D	Double-Acting
S	Spring-Return

Spring Set Number	
AG	Double-Acting
40	40 pound Spring Set
50	50 pound Spring Set
60	60 pound Spring Set
70	70 pound Spring Set
80	80 pound Spring Set
90	90 pound Spring Set
1C	100 pound Spring Set

Temperature Range	
S	Standard Temperature Range
H	High Temperature Range
L	Low Temperature Range
T	Tunnel Applications

Fail Action	
CW	Clockwise rotation (a.k.a. Spring to Close)
CC	Counterclockwise rotation (a.k.a. Spring to Open)

Coating/Finish	
Y	Standard Yellow
C	Commando

Bottom Stops	
0	No Bottom Stop Block/Standard Pistons
B	Bottom Stop Block/Over-travel Pistons
P	No Bottom Stop Block/Over-travel Pistons

High Flow Option	
0	No High Flow Option
1	Level 1 Option (1/2" NPT Plate No Drill)

Consult Factory for accurate speed calculations.



High Temperature Actuator

For general high temperature applications

These Hytork XL Actuators contain special soft parts, like O-ring seals, wear strips, bearings and grease to enable them to remain functional at high temperatures of up to +120°C / +248°F.

Option:

A special execution is available for Tunnel Applications. This execution allows higher temperatures than +120° / 248°F, but with a limited operational time and number of cycles (up to 250°C / 482°F, for a minimum of 2 hours).

Please see data sheet D120 for more details.

High temperature pistons

Hytork XL actuator sizes XL26 up to XL221 suitable for high temperature operation do not require special pistons.

Hytork XL actuator sizes XL281 up to XL4581 suitable for high temperature operation (-20°C to +120°C / -4°F to +248°F) require special pistons to keep the high temperature gear rack wear strip in place.

- In case of repair of a High Temperature actuator which will have the special pistons, only a repair kit is available. The repair kit contains all the necessary O-ring seals, bearings, washers and clip. Grease is not included.
- In case of a conversion from a standard temperature actuator to a High Temperature actuator which requires special pistons, the High Temperature conversion kits are available. The Conversion kit contains the special pistons and all the necessary O-ring seals, bearings, washers and clip. Grease is not included.

Specifications:

- Temperature range : -20°C to +120°C / -4°F to +248°F
- Dynamic O-ring seals : Flourocarbon Rubber 9775 (Viton).
- Static O-ring seals : Nitrile Rubber (Buna-N)
- Bearing material : High Temp composite laminate L10/G
- Grease : Rocol Sapphire Premier.

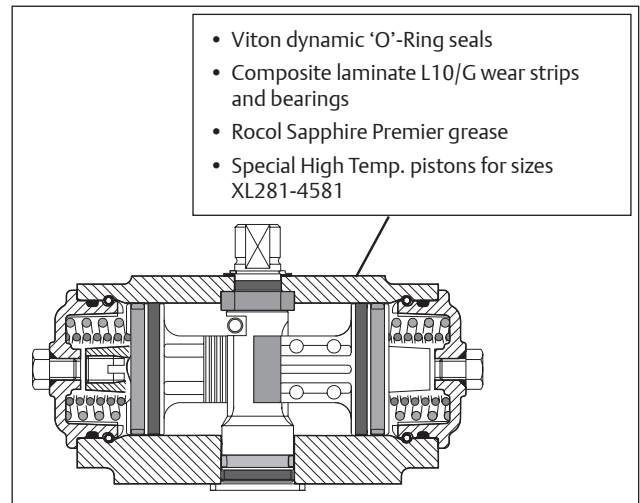

Component Description	Material	Qty	Model Numbers
Dynamic 'O'-ring Seals (to be exchanged)			
'O' ring Pinion top	Flourocarbon Rubber 9775 (Viton).	1	XL26 - XL4581
'O' ring Pinion Bottom	Flourocarbon Rubber 9775 (Viton).	1	XL26 - XL4581
'O' ring Piston	Flourocarbon Rubber 9775 (Viton).	2	XL26 - XL4581
Static 'O'-ring Seals (same as standard)			
'O' ring End Cap	Nitrile Rubber (Buna-N)	2	XL26 - XL4581
'O' ring SAFEKEY Head	Nitrile Rubber (Buna-N)	2	XL26 - XL4581
Thread Seal	Stainless Steel / Rubber	2	XL26 - XL221
'O' ring Limit Stops	Nitrile Rubber (Buna-N)	2	XL281 - XL1372
'O' ring End Cap Stop bolt	Nitrile Rubber (Buna-N)	2	XL26 - XL4581
Pistons, Wear Strips and Bearings (to be exchanged)			
High Temp. Pistons	Aluminum Alloy + dowel pin	2	XL281 - XL4581
Piston Wear Strips	High Temp composite laminate L10/G	2	XL26 - XL4581
Piston Head Glide Ring	High Temp composite laminate L10/G	2	XL26 - XL4581
Pinion Top Bearing	High Temp composite laminate L10/G	1	XL26 - XL4581
Pinion Bottom Bearing	High Temp composite laminate L10/G	1	XL26 - XL4581

Hytorch “TA” Tunnel Applications actuator

For use in conjunction with Tunnel Transit Damper which exceeds a test to operate safely at 250°/482°F for a minimum of two hours

“Tunnel Applications”

In modern traffic tunnels the venting system that removes or blocks toxic gasses and blinding smoke, is required to function in support of a safety window in time and operate for a number of cycles, both during and after a fire.

During such a fire, relative high temperatures may be reached around the venting system and systems must have the ability to continue operating during this critical safety window. These venting systems combine a louvred damper driven by a pneumatic actuator that vents or blocks the air flow in a tunnel and is constructed to operate safely at temperatures of up to 250°C ~ 482°F for a minimum of two hours.

The Hytorch TA Solution

Emerson has developed a Hytorch brand spring return actuator for these kinds of high demanding “Tunnel Applications” that can cope with these requirements. The actuator is equipped with special seals, bearings and grease to accommodate these temperatures.

Under normal conditions the actuator functions as a normal Spring Return actuator, and in the case of a fire the actuator will be able to function a number of times under the below mentioned conditions.

Conformance Test Procedure:

Test actuators have been subjected to a specific high temperature / functional test as follows;

Step	Description
1.	Measure Torque output before test.
2.	Actuator put in oven, which is already at 250°C/ 482°F.
3.	Cycle Actuator at beginning of 2 hour period.
4.	Cycle Actuator every 15 minutes in oven at 250°C/ 482°F.
5.	Cycle Actuator several times at end of 2 hour period.
6.	Measure Torque output After test.

The test report is available on request.

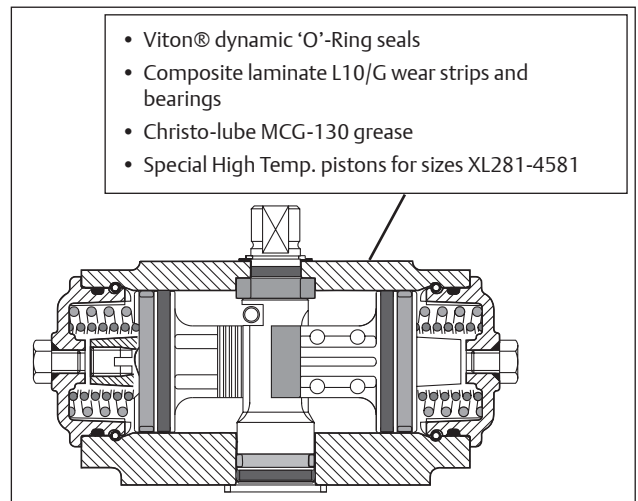

Specifications:

Temperature range

Normal operation (No fire)	: -20°C to +120°C : -4°F to + 248°F
Tunnel Application (Under fire)	: -20°C to +250°C for 2 hours minimum : -4°F to / +482°F for 2 hours minimum

Dynamic O-ring seals : Fluorocarbon Rubber 9775 (Viton®).

Static O-ring seals : Nitrile Rubber (Buna-N)

Bearing material : High temperature composite laminate L10/G

Grease : Christo-lube MCG-130

High temperature effects on output torque.

Spring stroke

Due to the high temperatures occurring during a fire, the spring torque will reduce due to the annealing affect of the heat, causing a drop in output torque of about 10% on the spring stroke. The attached torque table reflects the torque output of a standard actuator with 10% torque loss on the spring stroke after a fire.

Air stroke

The table shows also the torque output of the air stroke. Note that these torque values are in some cases much higher (compared to a standard actuator) depending on the supply pressure and the chosen spring set.

Sizing instructions

To select the right size of the actuator for a tunnel application two things have to be checked:

1 Sizing

- a Choose the smallest actuator size for **normal operation (no fire)**. Use the torque figures as per data sheet
Imperial data D67 (see web site).
Metric data D66 (see web site).
- b Choose the smallest actuator size **operation under fire**. Use the attached output torque table on page 3 and 4.
Use normal sizing procedure to define smallest actuator. Note that the air stroke torque output values are always higher than the spring torque values.
- c Select the largest actuator from “a” or “b”.

Note:

We recommend that the valve (or louver) manufacturer supplies the maximum required torque values, including any adjustments or suggested safety factors for valve or louver service conditions or application.

Additionally, the valve manufacturer must identify at which position(s) and direction(s) of rotation (Counter Clock Wise or Clock Wise) these maximum requirements occur.

2 Check the maximum valve stem torque

Check the maximum valve stem torque for the chosen smallest actuator size. The maximum valve stem torque should be lower than the output torque on the air stroke.

For venting louvres, the drive mechanism should be capable to cope with the maximum air stroke torque output torque of the chosen actuator.

Important: Use the maximum available plant pressure to define the maximum torque output on the air stroke of the actuator.

High temperature effects on actuator components

A high temperature operation as indicated under “Test Procedure” has influence on the:

- Springs; spring forces decreased.
- Grease; will dry out and might get hard.
- Soft parts; will lose their original shape and or strength.

Therefore we strongly recommend replacing the actuator after a high temperature operation as indicated under “Conformance Test Procedure”.

WARNING : Use only Spring Return (fail safe) models – Do not use Double Acting models, where the air needs to be driven in both directions.

At high temperatures of 250°C / 482°F, there is a risk that the plastic head and the rubber ‘o’ ring of the metal SafeKey could melt. This will cause complete torque loss on the inward stroke of double acting models.

We therefore advise to use only Spring Return models for these “Tunnel Applications”.

This problem does not occur on Spring Return models because the end cap chambers on Spring Return are normally not pressurized.

High temperature pistons

Hytorch XL actuator sizes XL26 up to XL221 suitable for Tunnel Applications, do not require special pistons.

Hytorch XL actuator sizes XL281 up to XL4581 suitable for Tunnel Applications, require special pistons to keep the high temperature gear rack wear strip in place.

- In case of repair of a Tunnel Applications actuator, which will have the special pistons, only a repair kit is available. The repair kit contains all the necessary O-ring seals, bearings, washers and clip. Grease is not included.
- In case of a conversion from a standard temperature actuator to a Tunnel Applications actuator, which requires special pistons, the High Temperature conversion kits are available. The Conversion kit contains the special pistons and all the necessary O-ring seals, bearings, washers and clip. Grease is not included.

Torque output values for use on Tunnel applications

Spring Return Actuators (Nm), XL26 to XL681

Model Number	Spring Rating	Torque from Springs		Torques from air stroke (Nm) at given operating air pressure (bar)													
		Start	End	3.0 bar(g)		4.0 bar(g)		5.0 bar(g)		5.5 bar(g)		6.0 bar(g)		7.0 bar(g)		8.0 bar(g)	
				Start	End	Start	End	Start	End	Start	End	Start	End	Start	End	Start	End
XL26	S40	5	3	7	5	11	8	14	12	16	14	17	15	21	19	24	22
	S50	7	4	6	4	10	7	13	11	15	12	17	14	20	17	24	21
	S60	8	5	6	2	9	6	12	9	14	11	16	13	19	16	23	20
	S70	9	6	-	-	8	4	12	8	13	10	15	11	18	15	22	18
	S80	11	6	-	-	7	3	11	7	13	8	14	10	18	13	21	17
	S90	12	7	-	-	7	2	10	5	12	7	13	9	17	12	20	16
S1C	13	8	-	-	-	-	9	4	11	6	13	7	16	11	20	14	
XL71	S40	13	8	18	12	26	21	35	30	39	34	44	38	52	47	61	55
	S50	17	10	16	9	24	18	33	26	37	31	42	35	50	44	59	52
	S60	20	12	14	6	22	14	31	23	35	27	40	32	48	40	57	49
	S70	23	14	-	-	20	11	29	20	33	24	38	28	46	37	55	45
	S80	27	16	-	-	18	8	27	16	31	21	36	25	44	34	53	42
	S90	30	18	-	-	16	4	25	13	29	17	34	22	42	30	51	39
S1C	33	20	-	-	-	-	23	10	27	14	32	18	40	27	49	35	
XL131	S40	25	15	33	23	50	40	66	56	74	64	82	72	98	88	114	104
	S50	31	19	30	17	46	33	62	50	70	58	78	66	94	82	111	98
	S60	38	23	26	11	42	27	58	43	66	51	75	59	91	76	107	92
	S70	44	26	-	-	38	21	55	37	63	45	71	53	87	69	103	86
	S80	50	30	-	-	35	15	51	31	59	39	67	47	83	63	99	79
	S90	56	34	-	-	31	8	47	24	55	33	63	41	79	57	96	73
S1C	63	38	-	-	-	-	43	18	51	26	59	34	76	51	92	67	
XL186	S40	34	20	45	32	67	53	89	75	100	86	110	97	132	119	154	140
	S50	42	25	40	23	62	45	84	67	94	78	105	89	127	110	149	132
	S60	50	30	35	15	57	37	79	58	89	69	100	80	122	102	144	124
	S70	59	35	-	-	52	28	74	50	84	61	95	72	117	94	139	115
	S80	67	40	-	-	47	20	68	42	79	52	90	63	112	85	134	107
	S90	76	45	-	-	42	11	63	33	74	44	85	55	107	77	129	98
S1C	84	50	-	-	-	-	58	25	69	36	80	47	102	68	124	90	
XL221	S40	47	28	63	44	93	74	123	105	139	120	154	135	184	165	214	196
	S50	59	35	56	32	86	62	116	93	131	108	147	123	177	153	207	184
	S60	71	42	49	20	79	51	109	81	124	96	140	111	170	142	200	172
	S70	82	49	-	-	72	39	102	69	117	84	133	100	163	130	193	160
	S80	94	56	-	-	65	27	95	58	110	73	125	88	156	118	186	148
	S90	106	63	-	-	58	15	88	46	103	61	118	76	149	106	179	137
S1C	118	71	-	-	-	-	81	34	96	49	111	64	142	95	172	125	
XL281	S40	58	34	75	51	111	87	148	124	166	142	184	160	220	196	256	233
	S50	72	42	67	37	103	73	139	109	157	127	176	146	212	182	248	218
	S60	86	51	58	22	95	59	131	95	149	113	167	131	203	167	240	204
	S70	101	59	-	-	86	44	122	80	141	99	159	117	195	153	231	189
	S80	115	67	-	-	78	30	114	66	132	84	150	102	187	139	223	175
	S90	130	76	-	-	-	-	106	52	124	70	142	88	178	124	214	160
S1C	144	84	-	-	-	-	97	37	115	55	133	74	170	110	206	146	
XL426	S40	85	51	108	74	161	127	214	180	240	206	267	233	320	286	372	339
	S50	106	63	95	53	148	106	201	159	228	185	254	212	307	265	360	318
	S60	127	76	83	32	136	85	188	138	215	164	241	191	294	244	347	296
	S70	148	89	-	-	123	64	176	117	202	143	229	169	282	222	334	275
	S80	169	101	-	-	110	43	163	95	190	122	216	148	269	201	322	254
	S90	190	114	-	-	-	-	150	74	177	101	203	127	256	180	309	233
S1C	211	127	-	-	-	-	138	53	164	80	191	106	244	159	296	212	
XL681	S40	136	82	177	123	263	209	350	295	393	338	436	381	522	468	608	554
	S50	170	102	157	89	243	175	329	261	372	304	415	347	502	434	588	520
	S60	204	122	136	55	223	141	309	227	352	270	395	313	481	400	567	486
	S70	238	143	-	-	202	107	288	193	331	236	375	279	461	366	547	452
	S80	272	163	-	-	182	73	268	159	311	202	354	245	440	332	527	418
	S90	306	183	-	-	-	-	248	125	291	168	334	211	420	298	506	384
S1C	340	204	-	-	-	-	227	91	270	134	313	178	400	264	486	350	

Note:

We recommend that the valve (or louvre) manufacturer supplies the maximum required torque values (Including any adjustments or suggested safety factors for valve or louvre service conditions or application). Additionally, the valve manufacturer must identify at which position(s) and direction(s) of rotation (Counter Clock Wise or Clock Wise) these maximum requirements occur.

Torque output values for use on Tunnel applications

Spring Return Actuators (Nm), XL1127 to XL4581

Model Number	Spring Rating	Torque from Springs		Torques from air stroke (Nm) at given operating air pressure (bar)													
		Start	End	3.0 bar(g)		4.0 bar(g)		5.0 bar(g)		5.5 bar(g)		6.0 bar(g)		7.0 bar(g)		8.0 bar(g)	
				Start	End	Start	End	Start	End	Start	End	Start	End	Start	End	Start	End
XL1127	S40	223	133	300	210	444	355	588	499	661	571	733	644	877	788	1021	932
	S50	278	167	266	155	411	299	555	444	627	516	699	588	844	732	988	877
	S60	334	200	233	99	377	244	522	388	594	460	666	532	810	677	955	821
	S70	390	233	-	-	344	188	488	332	560	404	633	477	777	621	921	765
	S80	445	267	-	-	311	132	455	277	527	349	599	421	744	565	888	710
	S90	501	300	-	-	277	77	422	221	494	293	566	365	710	510	855	654
S1C	556	334	-	-	-	-	388	165	460	237	533	310	677	454	821	598	
XL1372	S40	274	164	365	255	541	431	717	608	805	696	894	784	1070	960	1246	1137
	S50	342	205	324	186	500	363	676	539	764	627	852	715	1029	892	1205	1068
	S60	411	246	282	118	459	294	635	471	723	559	811	647	988	823	1164	1000
	S70	479	288	-	-	418	226	594	402	682	490	770	578	947	755	1123	931
	S80	548	329	-	-	377	157	553	334	641	422	729	510	906	686	1082	863
	S90	616	370	-	-	336	89	512	265	600	353	688	441	864	618	1041	794
S1C	685	411	-	-	-	-	471	197	559	285	647	373	823	549	1000	726	
XL2586	S40	517	310	689	482	1022	815	1355	1148	1521	1315	1688	1481	2021	1814	2354	2147
	S50	646	388	611	353	944	686	1277	1019	1444	1185	1610	1352	1943	1685	2277	2018
	S60	776	465	534	224	867	557	1200	890	1366	1056	1533	1223	1866	1556	2199	1889
	S70	905	543	-	-	789	427	1122	760	1289	927	1455	1093	1788	1426	2121	1760
	S80	1034	620	-	-	712	298	1045	631	1211	798	1378	964	1711	1297	2044	1630
	S90	1163	698	-	-	634	169	967	502	1134	668	1300	835	1633	1168	1966	1501
S1C	1293	776	-	-	-	-	890	373	1056	539	1223	706	1556	1039	1889	1372	
XL4581	S40	915	549	1214	848	1802	1436	2390	2024	2683	2318	2977	2611	3565	3199	4153	3787
	S50	1144	686	1077	620	1665	1207	2252	1795	2546	2089	2840	2383	3428	2970	4016	3558
	S60	1372	823	940	391	1527	979	2115	1566	2409	1860	2703	2154	3291	2742	3878	3329
	S70	1601	961	-	-	1390	750	1978	1337	2272	1631	2566	1925	3153	2513	3741	3101
	S80	1830	1098	-	-	1253	521	1841	1109	2135	1403	2428	1696	3016	2284	3604	2872
	S90	2059	1235	-	-	1116	292	1703	880	1997	1174	2291	1468	2879	2055	3467	2643
S1C	2287	1372	-	-	-	-	1566	651	1860	945	2154	1239	2742	1827	3329	2414	

Note:

We recommend that the valve (or louvre) manufacturer supplies the maximum required torque values (including any adjustments or suggested safety factors for valve or louvre service conditions or application). Additionally, the valve manufacturer must identify at which position(s) and direction(s) of rotation (Counter Clock Wise or Clock Wise) these maximum requirements occur.

Torque output values for use on Tunnel applications

Spring Return Actuators (In.lbs), XL26 to XL681

Model Number	Spring Rating	Torque from Springs		Torques from air stroke (in.lbs) at given operating air pressure (PSI)															
		Start	End	40 PSI		50 PSI		60 PSI		70 PSI		80 PSI		90 PSI		100 PSI		120 PSI	
				Start	End	Start	End	Start	End	Start	End	Start	End	Start	End	Start	End	Start	End
XL26	S40	47	28	55	36	76	57	97	78	118	99	139	120	159	141	180	161	222	203
	S50	59	35	48	24	69	45	90	66	111	87	131	108	152	129	173	150	215	191
	S60	71	43	41	13	62	33	83	54	104	75	124	96	145	117	166	138	208	179
	S70	83	50	-	-	55	22	76	42	96	63	117	84	138	105	159	126	201	168
	S80	95	57	-	-	-	-	68	31	89	52	110	72	131	93	152	114	194	156
	S90	106	64	-	-	-	-	61	19	82	40	103	61	124	81	145	102	187	144
S1C	118	71	-	-	-	-	-	-	75	28	96	49	117	70	138	90	179	132	
XL71	S40	118	71	138	90	190	143	242	195	294	247	346	299	399	351	451	403	555	508
	S50	148	89	120	61	172	113	224	165	276	217	329	270	381	322	433	374	537	478
	S60	177	106	102	31	154	84	207	136	259	188	311	240	363	292	415	344	520	449
	S70	207	124	-	-	137	54	189	106	241	158	293	211	345	263	398	315	502	419
	S80	236	142	-	-	-	-	171	77	223	129	275	181	328	233	380	285	484	390
	S90	266	159	-	-	-	-	153	47	206	99	258	151	310	204	362	256	466	360
S1C	295	177	-	-	-	-	-	-	188	70	240	122	292	174	344	226	449	331	
XL131	S40	222	133	259	170	357	268	455	366	553	465	651	563	750	661	848	759	1044	955
	S50	278	167	226	115	324	213	422	311	520	409	618	507	716	605	814	703	1011	899
	S60	333	200	192	59	291	157	389	255	487	353	585	452	683	550	781	648	977	844
	S70	389	233	-	-	257	102	355	200	453	298	552	396	650	494	748	592	944	788
	S80	444	267	-	-	-	-	322	144	420	242	518	340	616	439	714	537	911	733
	S90	500	300	-	-	-	-	289	89	387	187	485	285	583	383	681	481	877	677
S1C	555	333	-	-	-	-	-	-	353	131	452	229	550	327	648	426	844	622	
XL186	S40	297	178	349	230	481	362	613	494	745	626	877	758	1009	890	1141	1022	1405	1286
	S50	372	223	304	156	436	288	568	420	700	552	832	684	964	816	1096	948	1360	1211
	S60	446	268	260	82	392	214	523	346	655	478	787	610	919	741	1051	873	1315	1137
	S70	520	313	-	-	347	139	479	271	611	403	743	535	875	667	1007	799	1271	1063
	S80	595	357	-	-	-	-	435	197	566	328	698	460	830	592	962	724	1226	988
	S90	670	401	-	-	-	-	390	122	522	254	654	386	786	518	918	650	1182	914
S1C	744	446	-	-	-	-	-	-	478	179	610	311	741	443	873	575	1137	839	
XL221	S40	416	250	485	319	669	503	853	686	1037	870	1221	1054	1404	1238	1588	1422	1956	1789
	S50	520	312	423	215	607	399	791	582	974	766	1158	950	1342	1134	1526	1318	1893	1685
	S60	624	375	361	111	544	295	728	478	912	662	1096	846	1279	1030	1463	1213	1831	1581
	S70	728	437	-	-	482	190	666	374	849	558	1033	742	1217	926	1401	1109	1768	1477
	S80	833	500	-	-	-	-	603	270	787	454	971	638	1155	822	1338	1005	1706	1373
	S90	937	562	-	-	-	-	541	166	725	350	908	534	1092	717	1276	901	1643	1269
S1C	1041	624	-	-	-	-	-	-	662	246	846	430	1030	613	1213	797	1581	1165	
XL281	S40	510	298	581	369	801	589	1021	809	1241	1029	1461	1249	1681	1469	1901	1689	2340	2128
	S50	638	373	507	242	727	462	947	681	1166	901	1386	1121	1606	1341	1826	1561	2266	2001
	S60	765	447	432	114	652	334	872	554	1092	774	1312	994	1532	1214	1751	1433	2191	1873
	S70	893	522	-	-	578	207	797	426	1017	646	1237	866	1457	1086	1677	1306	2117	1746
	S80	1020	596	-	-	-	-	723	299	943	519	1163	739	1383	958	1602	1178	2042	1618
	S90	1148	671	-	-	-	-	648	171	868	391	1088	611	1308	831	1528	1051	1968	1491
S1C	1276	745	-	-	-	-	-	-	794	264	1014	483	1233	703	1453	923	1893	1363	
XL426	S40	748	449	834	535	1155	855	1475	1176	1796	1497	2116	1817	2437	2138	2758	2458	3399	3100
	S50	935	561	722	348	1042	668	1363	989	1684	1310	2004	1630	2325	1951	2645	2271	3287	2913
	S60	1122	673	610	161	930	481	1251	802	1571	1123	1892	1443	2213	1764	2533	2084	3175	2726
	S70	1309	785	-	-	818	294	1139	615	1459	936	1780	1256	2101	1577	2421	1898	3062	2539
	S80	1496	897	-	-	-	-	1027	428	1347	749	1668	1069	1988	1390	2309	1711	2950	2352
	S90	1683	1009	-	-	-	-	914	241	1235	562	1556	882	1876	1203	2197	1524	2838	2165
S1C	1870	1122	-	-	-	-	-	-	1123	375	1443	695	1764	1016	2085	1337	2726	1978	
XL681	S40	1203	722	1369	888	1891	1410	2414	1933	2937	2455	3459	2978	3982	3501	4505	4023	5550	5069
	S50	1504	902	1188	587	1711	1110	2234	1632	2756	2155	3279	2677	3801	3200	4324	3723	5369	4768
	S60	1804	1083	1008	286	1531	809	2053	1331	2576	1854	3098	2377	3621	2899	4144	3422	5189	4467
	S70	2105	1263	-	-	1350	508	1873	1031	2395	1553	2918	2076	3441	2599	3963	3121	5008	4166
	S80	2406	1443	-	-	-	-	1692	730	2215	1253	2738	1775	3260	2298	3783	2820	4828	3866
	S90	2707	1624	-	-	-	-	1512	429	2034	952	2557	1474	3080	1997	3602	2520	4648	3565
S1C	3007	1804	-	-	-	-	-	-	1854	651	2377	1174	2899	1696	3422	2219	4467	3264	

Note:
We recommend that the valve (or louvre) manufacturer supplies the maximum required torque values (Including any adjustments or suggested safety factors for valve or louvre service conditions or application). Additionally, the valve manufacturer must identify at which position(s) and direction(s) of rotation (Counter Clock Wise or Clock Wise) these maximum requirements occur.

Torque output values for use on Tunnel applications

Spring Return Actuators (In.lbs), XL1127 to XL4581

Model Number	Spring Rating	Torque from Springs		Torques from air stroke (in.lbs) at given operating air pressure (PSI)																
		Start	End	40		50		60		70		80		90		100		120		
				Start	End	Start	End	Start	End	Start	End	Start	End	Start	End	Start	End	Start	End	
XL1127	S40	1970	1181	2319	1530	3194	2405	4069	3280	4944	4155	5819	5030	6694	5905	7569	6780	9319	8530	
	S50	2462	1476	2024	1038	2899	1913	3774	2788	4649	3663	5524	4538	6399	5413	7274	6288	9024	8038	
	S60	2955	1771	1729	545	2604	1420	3479	2295	4354	3170	5229	4045	6104	4920	6979	5795	8729	7545	
	S70	3447	2066	-	-	2309	928	3184	1803	4059	2678	4934	3553	5809	4428	6684	5303	8434	7053	
	S80	3940	2361	-	-	-	-	2889	1310	3764	2185	4639	3060	5514	3935	6389	4810	8139	6560	
	S90	4432	2657	-	-	-	-	2593	818	3468	1693	4343	2568	5218	3443	6093	4318	7843	6068	
S1C	4925	2952	-	-	-	-	-	-	3173	1200	4048	2075	4923	2950	5798	3825	7548	5575		
XL1372	S40	2425	1454	2821	1850	3889	2919	4958	3988	6027	5056	7096	6125	8164	7194	9233	8263	11372	10400	
	S50	3031	1818	2457	1244	3526	2313	4595	3381	5663	4450	6732	5519	7801	6588	8870	7656	11007	9794	
	S60	3637	2181	2094	638	3162	1707	4231	2775	5300	3844	6369	4913	7437	5982	8506	7050	10644	9188	
	S70	4243	2545	-	-	2799	1100	3867	2169	4936	3238	6005	4307	7074	5375	8142	6444	10280	8582	
	S80	4850	2909	-	-	-	-	3504	1563	4573	2632	5641	3700	6710	4769	7779	5838	9916	7975	
	S90	5456	3272	-	-	-	-	3140	957	4209	2025	5278	3094	6347	4163	7415	5232	9553	7369	
S1C	6062	3636	-	-	-	-	-	-	3845	1419	4914	2488	5983	3557	7052	4625	9189	6763		
XL2586	S40	4576	2746	5329	3499	7348	5518	9367	7537	11386	9556	13404	11574	15423	13593	17442	15612	21479	19649	
	S50	5720	3432	4643	2355	6662	4374	8681	6393	10699	8412	12718	10430	14737	12449	16756	14468	20793	18505	
	S60	6863	4118	3957	1212	5975	3230	7994	5249	10013	7268	12032	9287	14050	11305	16069	13324	20107	17362	
	S70	8007	4805	-	-	5289	2086	7308	4105	9327	6124	11345	8143	13364	10161	15383	12180	19420	16218	
	S80	9151	5491	-	-	-	-	6621	2961	8640	4980	10659	6999	12678	9018	14696	11036	18734	15074	
	S90	10295	6177	-	-	-	-	5935	1817	7954	3836	9973	5855	11991	7874	14010	9892	18048	13930	
S1C	11439	6864	-	-	-	-	-	-	7267	2692	9286	4711	11305	6730	13324	8748	17361	12786		
XL4581	S40	8097	4858	9392	6153	12955	9716	16517	13278	20080	16841	23642	20403	27205	23966	30767	27528	37892	34653	
	S50	10121	6072	8178	4129	11740	7692	15303	11254	18865	14817	22428	18379	25990	21942	29553	25504	36678	32629	
	S60	12145	7287	6963	2105	10526	5667	14088	9230	17651	12792	21213	16355	24776	19917	28338	23480	35463	30605	
	S70	14169	8501	-	-	9311	3643	12874	7206	16436	10768	19999	14331	23561	17893	27124	21456	34249	28581	
	S80	16194	9716	-	-	-	-	11659	5181	15222	8744	18784	12306	22347	15869	25909	19431	33034	26556	
	S90	18218	10930	-	-	-	-	10445	3157	14007	6720	17570	10282	21132	13845	24695	17407	31820	24532	
S1C	20242	12145	-	-	-	-	-	-	-	-	-	-	16355	8258	19918	11821	23480	15383	30605	22508

Note:

We recommend that the valve (or louvre) manufacturer supplies the maximum required torque values (including any adjustments or suggested safety factors for valve or louvre service conditions or application). Additionally, the valve manufacturer must identify at which position(s) and direction(s) of rotation (Counter Clock Wise or Clock Wise) these maximum requirements occur.

Low Temperature Actuator

For for general low temperature applications

These Hytork XL Actuators contain special 'O'-ring seals, and grease to enable them to remain functional at low temperatures of down to -40°C / -40°F

Hytork XL actuators can be supplied as standard with a Low Temperature trim kit. To upgrade standard Hytork XL actuators to this Low Temperature variation or for maintenance, trim kits are available with the appropriate parts and instructions.

Specifications:

- Temperature range : -40°C to +100°C / -40°F to +212°F
- Dynamic O-ring seals : Silicone Rubber 8870.
- Static O-ring seals : Nitrile Rubber (Buna-N)
- Bearing material : Acetal M90 (same as standard actuator)
- Grease : Amoil ISO-460 PC# 802 (ESL-5)

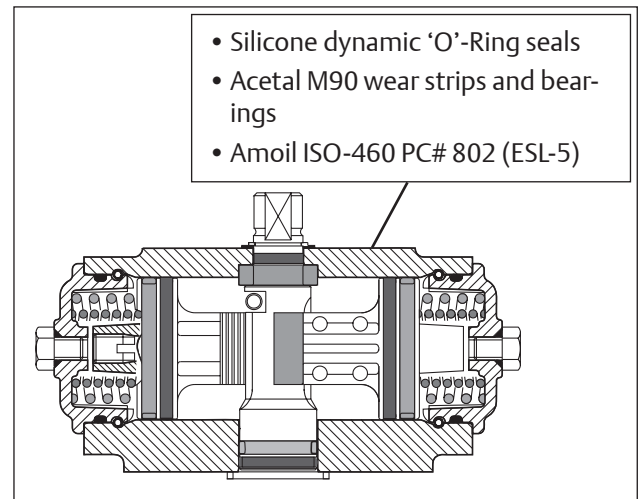

'Component Description	Material	Qty	Model Numbers
Dynamic 'O'-ring Seals (to be exchanged)			
'O' ring Pinion top	Silicone Rubber 8870	1	XL26 - XL4581
'O' ring Pinion Bottom	Silicone Rubber 8870	1	XL26 - XL4581
'O' ring Piston	Silicone Rubber 8870	2	XL26 - XL4581
Static 'O'-ring Seals (same as standard)			
'O' ring End Cap	Nitrile Rubber (Buna-N)	2	XL26 - XL4581
'O' ring SAFEKEY Head	Nitrile Rubber (Buna-N)	2	XL26 - XL4581
Thread Seal	Stainless Steel / Rubber	2	XL26 - XL221
'O' ring Limit Stops	Nitrile Rubber (Buna-N)	2	XL281 - XL1372
'O' ring End Cap Stop bolt	Nitrile Rubber (Buna-N)	2	XL26 - XL4581
Wear Strips and Bearings (to be exchanged)			
Piston Wear Strips	Acetal M90	2	XL26 - XL4581
Piston Head Glide Ring	Acetal M90	2	XL26 - XL4581
Pinion Top Bearing	Acetal M90	1	XL26 - XL4581
Pinion Bottom Bearing	Acetal M90	1	XL26 - XL4581

Standard corrosion protection system

Description:

The corrosion protection system of standard Hytork XL series pneumatic actuators consists of the following treatments or materials:

1. CERAMIGARD body treatment

The body and end caps have a unique surface finish of Di-aluminium Trioxide (Al₂O₃); a hard, corrosion resistant ceramic like surface, protecting body and end caps against wear and corrosion.

Prior to the CERAMIGARD body treatment the components are degreased to remove oil stain from the castings surface.

CERAMIGARD exceeds the requirements of specification MIL-A-8625, Type II, Class 1 and is applied with a layer thickness between 10 to 15 Microns.

2. Powder coating finish

- Polyurethane powder coating for exterior use.
- The powder coating is applied cold using automatic electrostatic spray equipment and is cured for about 10 minutes at minimum 200°C (392°F) offering excellent light and weather resistance.
- The powder coating thickness is between 80 and 160 microns.

- Good chemical resistance against most bases, acids, solvents, alkalis and oils at normal temperatures.
- Excellent exterior mechanical durability.
- The coating has passed a salt spray test according to ASTM B117 for 1000 hours.
- The powder coating is virtually solvent free, and therefore environmentally friendly.

3. Cobalt zinc plated pinion

All Hytork actuator pinions are Cobalt Zinc plated. Cobalt Zinc plating provides a uniform ductility that will withstand up to 6 times the corrosion resistance of conventional zinc plating.

4. Stainless steel travel stops

The travel stop screws and nuts are made of stainless steel. This assures positive sealing, correct port alignment and long life.

5. The chemical and durability assessment.

All these components and treatments including the durable pinion design, CERAMIGARD surface finish, standard powder coated paint and stainless steel travel stops shows no decline of actuator functions after 1000 hours salt spray test.

Test result polyurethane powder coating

No	Item	Standard	Specification
1	Hardness	ASTM D3363 Pencil (Mitsubishi Uni)	2H
2	Adhesion	ISO 2409, ASTM D3359 Cross hatch test (2mm)	Gt (0) 100% Adhesion
3	Impact test	ASTM D2794 5/8" Ball (direct)	Min. 25 lb.in without detachment
4	Bend test	DIN 53152, ISO1519, ASTM D522	Min 5 mm without cracking
5	Salt Spray resistance	ASTM B117 (1000 hours) "X-cut" (Zinc phosphated steel)	No Blistering Creep < 2 mm
6	Acid resistance	ISO 2812 5% H2SO4, 1 Hour	No Blistering
7	Alkali resistance	ISO 2812 5% Na CO3, 1 hour	No Blistering
8	Water resistance	20° C, 7 days	No Blistering
9	Boiling test	1 hour @ 98°C	No Blistering

This data sheet contains general information as supplied by the paint supplier and describes typical properties for the coating.

“Commando” corrosion protection system

Description:

The COMMANDO corrosion protection system of Hytork XL series pneumatic actuators consist of the following treatments or materials:

1 Pretreatment

Pretreatment is provided to ensure good adhesion and is applied in this order:

- Alkali wash of the body, end caps and pinions
- Acid wash of the body, end caps and pinions
- Alkali wash of the pistons.

2 Coating process

The aluminum body parts are treated with a Self-Priming one-coat blends of FEP fluoropolymer from the 954-101 range in a method that no extruded actuator body can receive, providing a complete, durable impregnation of all body parts, inside and out. The steel pinion is treated with 954-103.

The coating is applied to the body (inside and out), pinion and end caps by using spray equipment and dried and cured in an oven.

3 XL COMMANDO

The result is the “XL COMMANDO”. Years of field trials have proven this to be the answer to many corrosive environments. Light in weight, heavy in performance, state of the art design and a durable impregnation which guards against corrosion.

This durable impregnation can best be achieved in cast aluminum parts (all XL COMMANDO body parts are cast aluminum). As the aluminum metal grains are expanded under heat the 954-101 is applied, entering the grain structure and, upon cooling, is locked at the surface, integral with the grain structure. Extruded surfaces can only be coated and are more susceptible to scratches and other mechanical deterioration.

4 Valve position monitoring

To compliment the “XL COMMANDO” actuator range, Hytork has two solutions for valve position monitoring in corrosive environments.

- There is the proven “HyVision” (NEMA 4 and IP66) manufactured in corrosion resistant composite materials
- The “SafeVision COMMANDO” (NEMA 4,4X,7,9 & ATEX II 2 GD EEx d IIC T6 specifications) manufactured and treated using the same processes as the “XL COMMANDO” to provide a complete solution to many of your corrosive environment problems.
- This product is only intended for use in large-scale fixed installations excluded from the scope of Directive 2011/65/EU on the restriction of the use of certain hazardous substances in electrical and electronic equipment (RoHS 2).

5 Application

The “XL COMMANDO” is available in twelve sizes producing up to 35,000 in.lbs. (3954Nm) of torque for all types of 90 degree rotation valves. The “SafeVision COMMANDO” valve position monitors are available with up to four switches including proximity sensors and the “i MAX” hermetically sealed reed switch.

Specifications:

Coating	: Self-Priming one-coat FEP fluoropolymer.
Color	: Green for housing and end caps. : Black for the pinion.
Temperature	: -20° to + 100°C / -4°F to +212°F
Application	: Optional on Hytork XL pneumatic actuators and SafeVision switchboxes.

Envelope Dimensions and Torque Data

XL26 Double acting and Spring Return actuator

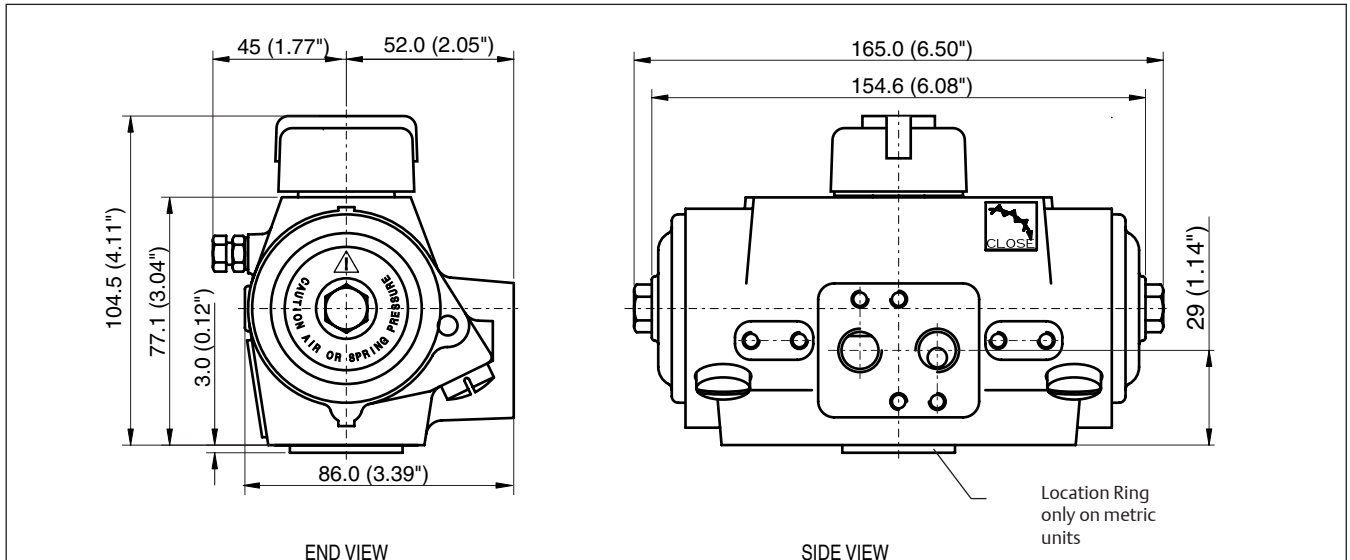

Torque in Nm, Pressure in bar(g)																
Double Acting Torques		10		14		17		19		21		24		28		
Spring Rating	Torque From Springs		3.0 bar(g)		4.0 bar(g)		5.0 bar(g)		5.5 bar(g)		6.0 bar(g)		7.0 bar(g)		8.0 bar(g)	
	Start	End	Start	End	Start	End	Start	End	Start	End	Start	End	Start	End	Start	End
S40	6	4	7	4	10	8	14	11	15	13	17	15	21	18	24	22
S50	7	4	6	3	9	6	13	10	14	12	16	13	20	17	23	20
S60	9	5	5	1	8	5	12	8	14	10	15	12	19	15	22	19
S70	10	6	-	-	8	3	11	7	13	9	14	10	18	14	21	17
S80	12	7	-	-	7	2	10	5	12	7	14	9	17	12	20	16
S90	13	8	-	-	-	-	9	4	11	6	13	7	16	11	20	14
S1C	15	9	-	-	-	-	8	2	10	4	12	6	15	9	19	13

Torque in inch-pounds, Pressure in PSI																
Double Acting Torques		83		104		125		167		188		209		250		
Spring Rating	Torque From Springs		40 PSI		50 PSI		60 PSI		80 PSI		90 PSI		100 PSI		120 PSI	
	Start	End	Start	End	Start	End	Start	End	Start	End	Start	End	Start	End	Start	End
S40	53	32	52	31	73	52	94	73	135	114	156	135	177	156	219	198
S50	66	39	44	18	65	39	86	60	128	101	148	122	169	143	211	185
S60	79	47	-	-	57	26	78	46	120	88	141	109	161	130	203	172
S70	92	55	-	-	-	-	70	33	112	75	133	96	153	117	195	158
S80	105	63	-	-	-	-	62	20	104	62	125	83	146	104	187	145
S90	118	71	-	-	-	-	-	-	96	49	117	70	138	90	179	132
S1C	131	79	-	-	-	-	-	-	88	36	109	57	130	77	172	119

Envelope Dimensions and Torque Data

XL71 Double acting and Spring Return actuator

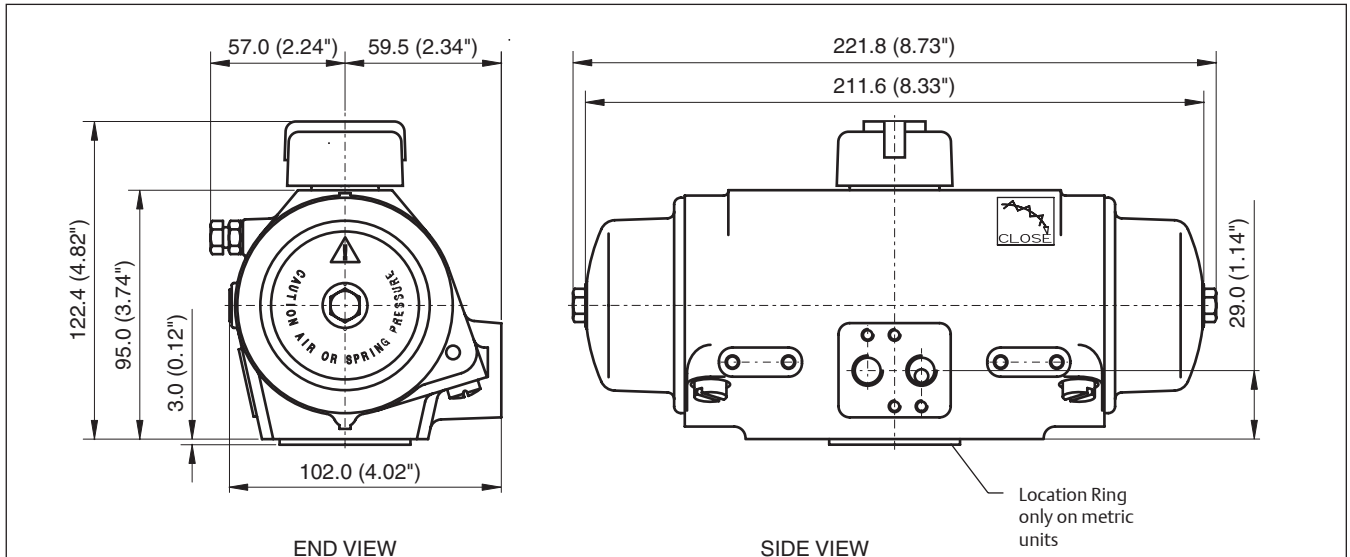

Torque in Nm, Pressure in bar(g)																
Double Acting Torques		26		34		43		47		52		60		69		
Spring Rating	Torque From Springs		3.0 bar(g)		4.0 bar(g)		5.0 bar(g)		5.5 bar(g)		6.0 bar(g)		7.0 bar(g)		8.0 bar(g)	
	Start	End	Start	End	Start	End	Start	End	Start	End	Start	End	Start	End	Start	End
S40	15	9	17	11	26	20	34	28	38	32	43	37	51	45	60	54
S50	19	11	15	7	23	16	32	24	36	29	41	33	49	42	58	50
S60	22	13	12	4	21	12	30	21	34	25	38	29	47	38	55	47
S70	26	16	-	-	19	8	27	17	32	21	36	26	45	34	53	43
S80	30	18	-	-	17	5	25	13	30	18	34	22	42	31	51	39
S90	33	20	-	-	-	-	23	10	27	14	32	18	40	27	49	35
S1C	37	22	-	-	-	-	21	6	25	10	29	15	38	23	47	32

Torque in inch-pounds, Pressure in PSI																
Double Acting Torques		209		261		313		417		469		521		626		
Spring Rating	Torque From Springs		40 PSI		50 PSI		60 PSI		80 PSI		90 PSI		100 PSI		120 PSI	
	Start	End	Start	End	Start	End	Start	End	Start	End	Start	End	Start	End	Start	End
S40	131	79	130	77	182	130	234	182	338	286	391	338	443	390	547	495
S50	164	98	110	45	162	97	214	149	319	253	371	305	423	357	527	462
S60	197	118	-	-	143	64	195	116	299	220	351	273	403	325	508	429
S70	230	138	-	-	-	-	175	83	279	188	332	240	384	292	488	396
S80	263	158	-	-	-	-	155	50	260	155	312	207	364	259	468	363
S90	295	177	-	-	-	-	-	-	240	122	292	174	344	226	449	331
S1C	328	197	-	-	-	-	-	-	220	89	273	141	325	193	429	298

Envelope Dimensions and Torque Data

XL131 Double acting and Spring Return actuator

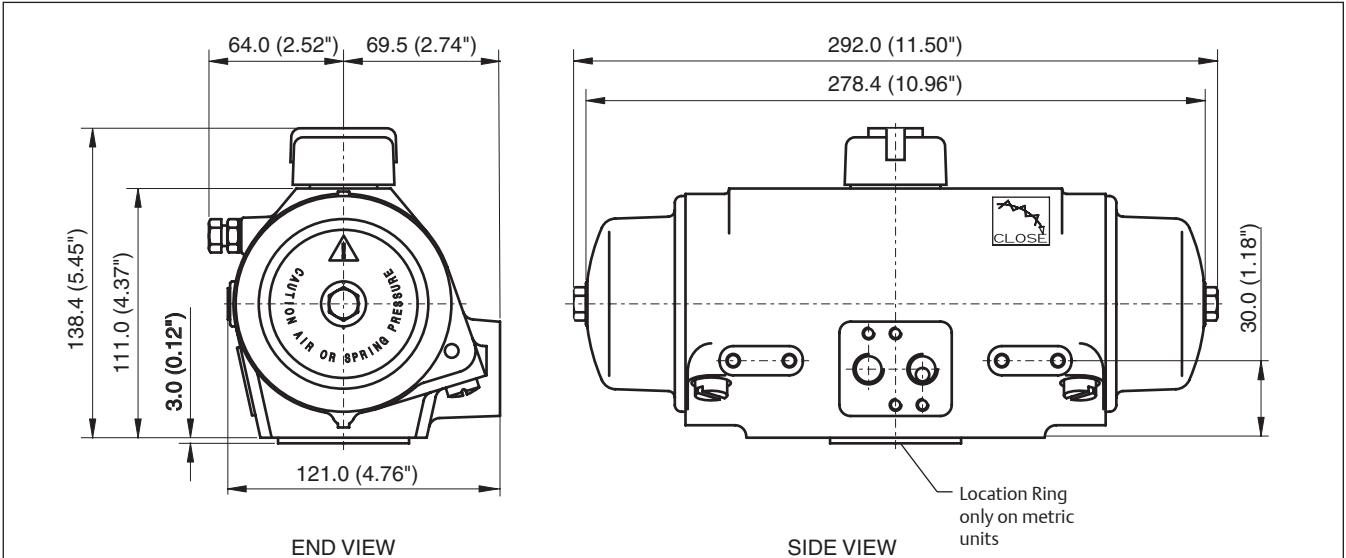

Torque in Nm, Pressure in bar(g)

Double Acting Torques		49		65		81		89		97		113		129		
Spring Rating	Torque From Springs		3.0 bar(g)		4.0 bar(g)		5.0 bar(g)		5.5 bar(g)		6.0 bar(g)		7.0 bar(g)		8.0 bar(g)	
	Start	End	Start	End	Start	End	Start	End	Start	End	Start	End	Start	End	Start	End
S40	28	17	32	21	48	37	64	53	72	61	80	69	97	85	113	102
S50	35	21	28	14	44	30	60	46	68	54	76	62	92	78	109	95
S60	42	25	23	7	40	23	56	39	64	47	72	55	88	71	104	88
S70	49	29	-	-	35	16	52	32	60	40	68	48	84	64	100	81
S80	56	33	-	-	31	9	47	25	56	33	64	41	80	57	96	74
S90	63	38	-	-	-	-	43	18	51	26	59	34	76	51	92	67
S1C	70	42	-	-	-	-	39	11	47	19	55	27	71	44	88	60

Torque in inch-pounds, Pressure in PSI

Double Acting Torques		392		491		589		785		883		981		1177		
Spring Rating	Torque From Springs		40 PSI		50 PSI		60 PSI		80 PSI		90 PSI		100 PSI		120 PSI	
	Start	End	Start	End	Start	End	Start	End	Start	End	Start	End	Start	End	Start	End
S40	247	148	244	146	342	244	440	342	637	538	735	636	833	734	1029	930
S50	309	185	207	84	305	182	403	280	600	476	698	574	796	672	992	869
S60	370	222	-	-	268	120	366	218	563	414	661	513	759	611	955	807
S70	432	259	-	-	-	-	329	157	526	353	624	451	722	549	918	745
S80	494	296	-	-	-	-	292	95	489	291	587	389	685	487	881	683
S90	555	333	-	-	-	-	-	-	452	229	550	327	648	426	844	622
S1C	617	370	-	-	-	-	-	-	414	168	513	266	611	364	807	560

Envelope Dimensions and Torque Data

XL186 Double acting and Spring Return actuator

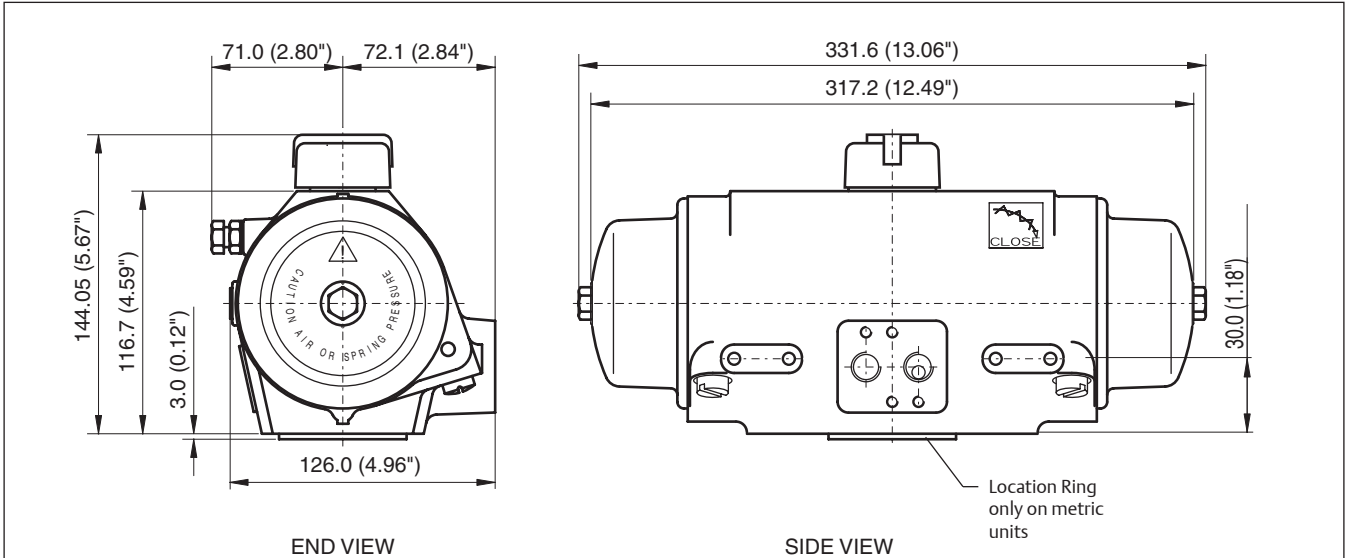

Torque in Nm, Pressure in bar(g)																
Double Acting Torques		65		87		109		120		131		152		174		
Spring Rating	Torque From Springs		3.0 bar(g)		4.0 bar(g)		5.0 bar(g)		5.5 bar(g)		6.0 bar(g)		7.0 bar(g)		8.0 bar(g)	
	Start	End	Start	End	Start	End	Start	End	Start	End	Start	End	Start	End	Start	End
S40	37	22	43	28	65	50	86	71	97	82	108	93	130	115	152	137
S50	47	28	37	19	59	40	81	62	92	73	102	84	124	106	146	127
S60	56	34	32	9	53	31	75	53	86	64	97	75	119	96	140	118
S70	65	39	-	-	48	22	70	43	80	54	91	65	113	87	135	109
S80	75	45	-	-	42	12	64	34	75	45	86	56	108	78	129	99
S90	84	50	-	-	-	-	58	25	69	36	80	46	102	68	124	90
S1C	93	56	-	-	-	-	53	15	64	26	75	37	96	59	118	81

Torque in inch-pounds, Pressure in PSI																
Double Acting Torques		528		660		792		1055		1187		1319		1583		
Spring Rating	Torque From Springs		40 PSI		50 PSI		60 PSI		80 PSI		90 PSI		100 PSI		120 PSI	
	Start	End	Start	End	Start	End	Start	End	Start	End	Start	End	Start	End	Start	End
S40	331	198	329	197	461	329	593	461	857	725	989	857	1121	989	1385	1253
S50	413	248	280	115	412	247	543	379	807	642	939	774	1071	906	1335	1170
S60	495	298	-	-	362	164	494	296	757	560	889	692	1021	824	1285	1088
S70	578	347	-	-	312	81	444	213	708	477	840	609	972	741	1236	1005
S80	661	397	-	-	-	-	395	130	659	394	791	526	923	658	1186	922
S90	744	446	-	-	-	-	-	-	609	311	741	443	873	575	1137	839
S1C	827	495	-	-	-	-	-	-	560	229	692	361	824	492	1088	756

Envelope Dimensions and Torque Data

XL221 Double acting and Spring Return actuator

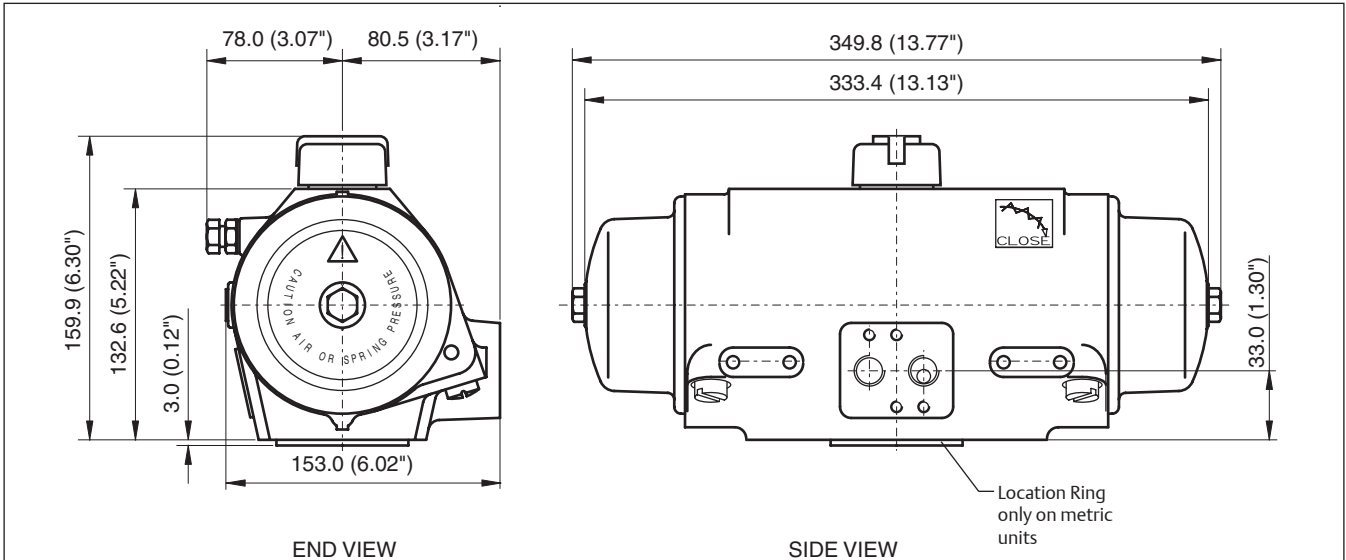

Torque in Nm, Pressure in bar(g)

Double Acting Torques		91		121		152		167		182		212		243		
Spring Rating	Torque From Springs		3.0 bar(g)		4.0 bar(g)		5.0 bar(g)		5.5 bar(g)		6.0 bar(g)		7.0 bar(g)		8.0 bar(g)	
	Start	End	Start	End	Start	End	Start	End	Start	End	Start	End	Start	End	Start	End
S40	52	31	60	39	90	69	120	99	135	114	151	130	181	160	211	190
S50	65	39	52	26	82	56	112	86	128	101	143	117	173	147	203	177
S60	78	47	44	13	74	43	105	73	120	88	135	104	165	134	196	164
S70	91	55	-	-	66	30	97	60	112	75	127	90	157	121	188	151
S80	105	63	-	-	59	17	89	47	104	62	119	77	150	108	180	138
S90	118	71	-	-	-	-	81	34	96	49	111	64	142	95	172	125
S1C	131	78	-	-	-	-	73	21	88	36	104	51	134	82	164	112

Torque in inch-pounds, Pressure in PSI

Double Acting Torques		735		919		1103		1470		1654		1838		2205		
Spring Rating	Torque From Springs		40 PSI		50 PSI		60 PSI		80 PSI		90 PSI		100 PSI		120 PSI	
	Start	End	Start	End	Start	End	Start	End	Start	End	Start	End	Start	End	Start	End
S40	463	278	458	273	641	456	825	640	1193	1008	1377	1192	1560	1375	1928	1743
S50	578	347	388	157	572	341	756	525	1123	892	1307	1076	1491	1260	1859	1627
S60	694	416	-	-	503	225	686	409	1054	777	1238	960	1422	1144	1789	1512
S70	809	486	-	-	-	-	617	293	985	661	1168	845	1352	1028	1720	1396
S80	925	555	-	-	-	-	548	178	915	545	1099	729	1283	913	1650	1280
S90	1041	624	-	-	-	-	-	-	846	430	1030	613	1213	797	1581	1165
S1C	1156	694	-	-	-	-	-	-	777	314	960	498	1144	682	1512	1049

Envelope Dimensions and Torque Data

XL281 Double acting and Spring Return actuator

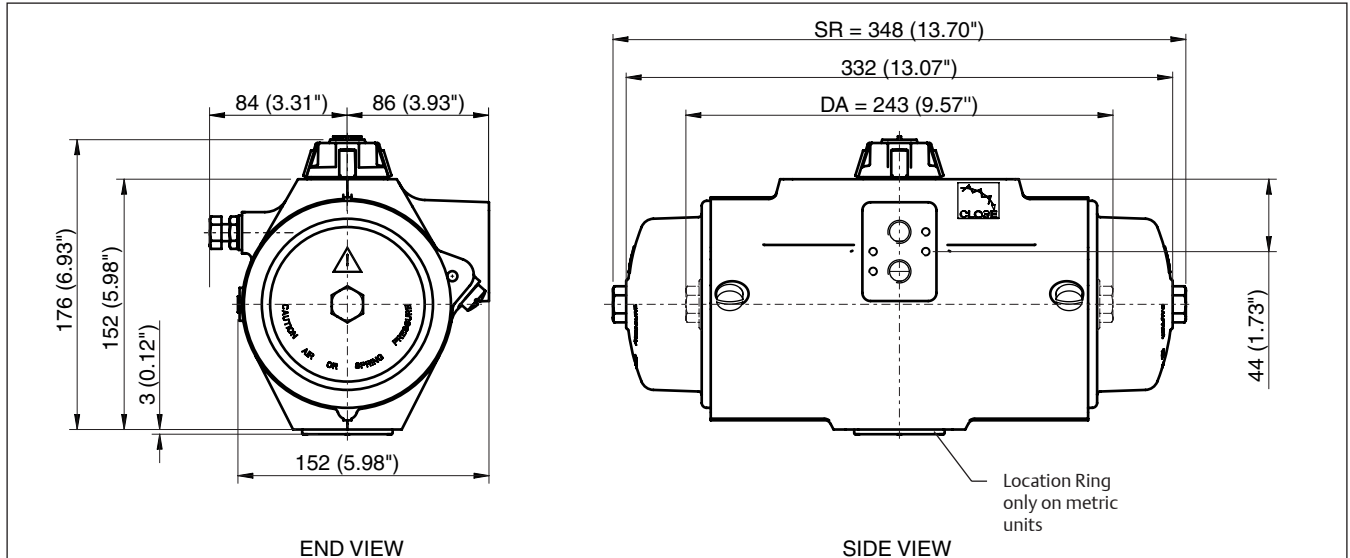

Torque in Nm, Pressure in bar(g)																
Double Acting Torques		109		145		181		200		218		254		290		
Spring Rating	Torque From Springs		3.0 bar(g)		4.0 bar(g)		5.0 bar(g)		5.5 bar(g)		6.0 bar(g)		7.0 bar(g)		8.0 bar(g)	
	Start	End	Start	End	Start	End	Start	End	Start	End	Start	End	Start	End	Start	End
S40	64	37	71	45	108	81	144	117	162	135	180	154	216	190	253	226
S50	80	47	62	29	98	65	135	101	153	119	171	138	207	174	243	210
S60	96	56	-	-	89	49	125	85	143	103	161	122	198	158	234	194
S70	112	66	-	-	80	33	116	69	134	87	152	106	188	142	225	178
S80	128	75	-	-	-	-	106	53	125	71	143	90	179	126	215	162
S90	144	84	-	-	-	-	97	37	115	55	133	74	170	110	206	146
S1C	160	94	-	-	-	-	-	-	106	39	124	57	160	94	197	130

Torque in inch-pounds, Pressure in PSI																
Double Acting Torques		880		1099		1319		1759		1979		2199		2639		
Spring Rating	Torque From Springs		40 PSI		50 PSI		60 PSI		80 PSI		90 PSI		100 PSI		120 PSI	
	Start	End	Start	End	Start	End	Start	End	Start	End	Start	End	Start	End	Start	End
S40	567	331	548	313	768	532	988	752	1428	1192	1648	1412	1867	1632	2307	2072
S50	709	414	465	171	685	391	905	611	1345	1050	1565	1270	1785	1490	2224	1930
S60	850	497	-	-	602	249	822	469	1262	909	1482	1129	1702	1348	2142	1788
S70	992	580	-	-	-	-	739	327	1179	767	1399	987	1619	1207	2059	1646
S80	1134	663	-	-	-	-	657	185	1096	625	1316	845	1536	1065	1976	1505
S90	1276	745	-	-	-	-	-	-	1014	483	1233	703	1453	923	1893	1363
S1C	1417	828	-	-	-	-	-	-	931	342	1151	562	1370	782	1810	1221

Envelope Dimensions and Torque Data

XL426 Double acting and Spring Return actuator

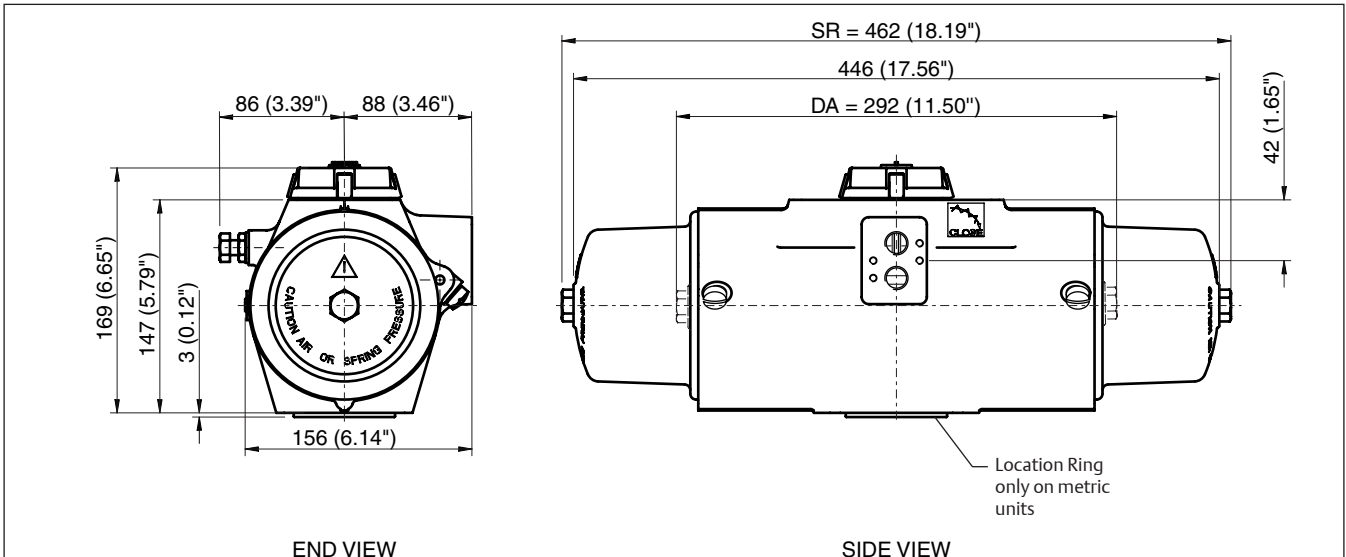

Torque in Nm, Pressure in bar(g)																
Double Acting Torques		159		212		264		291		317		370		423		
Spring Rating	Torque From Springs		3.0 bar(g)		4.0 bar(g)		5.0 bar(g)		5.5 bar(g)		6.0 bar(g)		7.0 bar(g)		8.0 bar(g)	
	Start	End	Start	End	Start	End	Start	End	Start	End	Start	End	Start	End	Start	End
S40	94	56	102	65	155	118	208	171	235	197	261	223	314	276	367	329
S50	117	70	88	41	141	94	194	147	221	174	247	200	300	253	353	306
S60	141	84	-	-	127	71	180	124	206	150	233	177	286	229	339	282
S70	164	99	-	-	113	47	166	100	192	127	219	153	272	206	325	259
S80	188	113	-	-	-	-	152	77	178	103	205	130	258	182	311	235
S90	211	127	-	-	-	-	138	53	164	80	191	106	244	159	296	212
S1C	235	141	-	-	-	-	-	-	150	56	177	83	229	136	282	188

Torque in inch-pounds, Pressure in PSI																
Double Acting Torques		1283		1603		1924		2565		2886		3206		3848		
Spring Rating	Torque From Springs		40 PSI		50 PSI		60 PSI		80 PSI		90 PSI		100 PSI		120 PSI	
	Start	End	Start	End	Start	End	Start	End	Start	End	Start	End	Start	End	Start	End
S40	831	498	784	452	1105	772	1425	1093	2067	1734	2387	2055	2708	2375	3349	3017
S50	1039	623	659	244	980	564	1301	885	1942	1526	2263	1847	2583	2168	3224	2809
S60	1246	748	-	-	855	357	1176	677	1817	1319	2138	1639	2459	1960	3100	2601
S70	1454	872	-	-	-	-	1051	470	1693	1111	2013	1431	2334	1752	2975	2393
S80	1662	997	-	-	-	-	927	262	1568	903	1889	1224	2209	1544	2851	2186
S90	1870	1122	-	-	-	-	-	-	1443	695	1764	1016	2085	1337	2726	1978
S1C	2077	1246	-	-	-	-	-	-	1319	488	1639	808	1960	1129	2601	1770

Envelope Dimensions and Torque Data

XL681 Double acting and Spring Return actuator

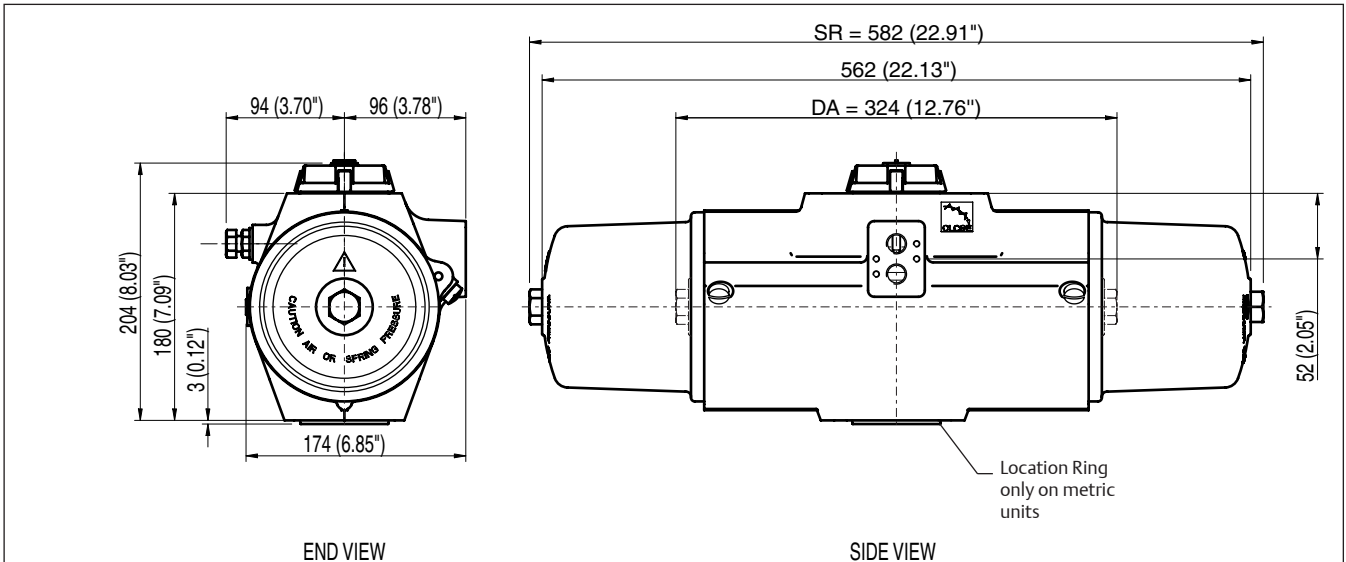

Torque in Nm, Pressure in bar(g)																
Double Acting Torques		259		345		431		474		517		604		690		
Spring Rating	Torque From Springs		3.0 bar(g)		4.0 bar(g)		5.0 bar(g)		5.5 bar(g)		6.0 bar(g)		7.0 bar(g)		8.0 bar(g)	
	Start	End	Start	End	Start	End	Start	End	Start	End	Start	End	Start	End	Start	End
S40	151	91	168	108	254	194	340	280	384	323	427	366	513	453	599	539
S50	189	113	145	70	232	156	318	242	361	285	404	329	490	415	576	501
S60	227	136	123	32	209	118	295	205	338	248	381	291	468	377	554	463
S70	264	159	-	-	186	81	273	167	316	210	359	253	445	339	531	425
S80	302	181	-	-	164	43	250	129	293	172	336	215	422	301	509	388
S90	340	204	-	-	-	-	227	91	270	134	313	178	400	264	486	350
S1C	378	227	-	-	-	-	205	54	248	97	291	140	377	226	463	312

Torque in inch-pounds, Pressure in PSI																
Double Acting Torques		2091		2613		3136		4181		4704		5226		6272		
Spring Rating	Torque From Springs		40 PSI		50 PSI		60 PSI		80 PSI		90 PSI		100 PSI		120 PSI	
	Start	End	Start	End	Start	End	Start	End	Start	End	Start	End	Start	End	Start	End
S40	1337	802	1289	754	1811	1277	2334	1799	3379	2844	3902	3367	4424	3890	5470	4935
S50	1671	1002	1088	420	1611	942	2133	1465	3179	2510	3701	3033	4224	3556	5269	4601
S60	2005	1203	-	-	1410	608	1933	1131	2978	2176	3501	2699	4023	3221	5069	4267
S70	2339	1403	-	-	-	-	1732	797	2778	1842	3300	2365	3823	2887	4868	3933
S80	2673	1604	-	-	-	-	1532	463	2577	1508	3100	2031	3622	2553	4668	3598
S90	3007	1804	-	-	-	-	-	-	2377	1174	2899	1696	3422	2219	4467	3264
S1C	3341	2005	-	-	-	-	-	-	2176	840	2699	1362	3221	1885	4267	2930

Envelope Dimensions and Torque Data

XL1127 Double acting and Spring Return actuator

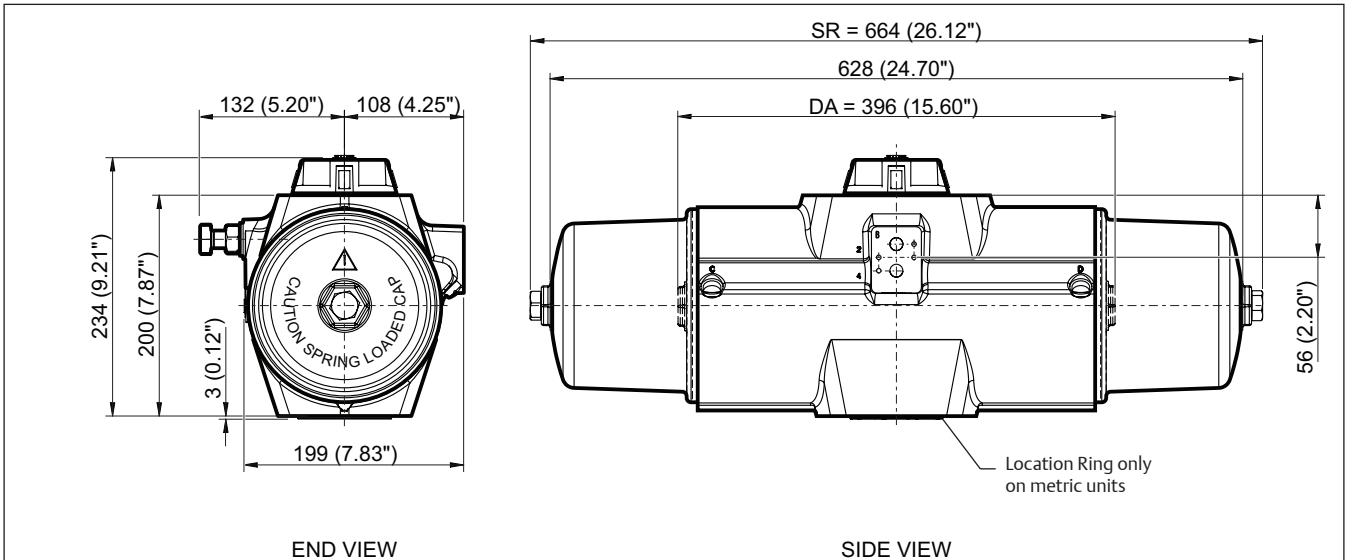

Torque in Nm, Pressure in bar(g)																
Double Acting Torques		433		577		722		794		866		1010		1155		
Spring Rating	Torque From Springs		3.0 bar(g)		4.0 bar(g)		5.0 bar(g)		5.5 bar(g)		6.0 bar(g)		7.0 bar(g)		8.0 bar(g)	
	Start	End	Start	End	Start	End	Start	End	Start	End	Start	End	Start	End	Start	End
S40	247	148	285	186	429	330	574	474	646	547	718	619	862	763	1007	907
S50	309	185	248	124	392	268	536	413	609	485	681	557	825	701	970	846
S60	371	222	211	62	355	206	499	351	572	423	644	495	788	639	932	784
S70	433	259	-	-	318	145	462	289	535	361	607	433	751	578	895	722
S80	495	296	-	-	281	83	425	227	497	299	570	371	714	516	858	660
S90	556	334	-	-	-	-	388	165	460	237	533	310	677	454	821	598
S1C	618	371	-	-	-	-	351	103	423	176	495	248	640	392	784	537

Torque in inch-pounds, Pressure in PSI																
Double Acting Torques		3500		4375		5250		7000		7875		8750		10500		
Spring Rating	Torque From Springs		40 PSI		50 PSI		60 PSI		80 PSI		90 PSI		100 PSI		120 PSI	
	Start	End	Start	End	Start	End	Start	End	Start	End	Start	End	Start	End	Start	End
S40	2189	1312	2188	1311	3063	2186	3938	3061	5688	4811	6563	5686	7438	6561	9188	8311
S50	2736	1640	1860	764	2735	1639	3610	2514	5360	4264	6235	5139	7110	6014	8860	7764
S60	3283	1968	-	-	2407	1092	3282	1967	5032	3717	5907	4592	6782	5467	8532	7217
S70	3830	2296	-	-	2079	545	2954	1420	4704	3170	5579	4045	6454	4920	8204	6670
S80	4377	2624	-	-	-	-	2626	873	4376	2623	5251	3498	6126	4373	7876	6123
S90	4925	2952	-	-	-	-	-	-	4048	2075	4923	2950	5798	3825	7548	5575
S1C	5472	3280	-	-	-	-	-	-	3720	1528	4595	2403	5470	3278	7220	5028

Envelope Dimensions and Torque Data

XL1372 Double acting and Spring Return actuator

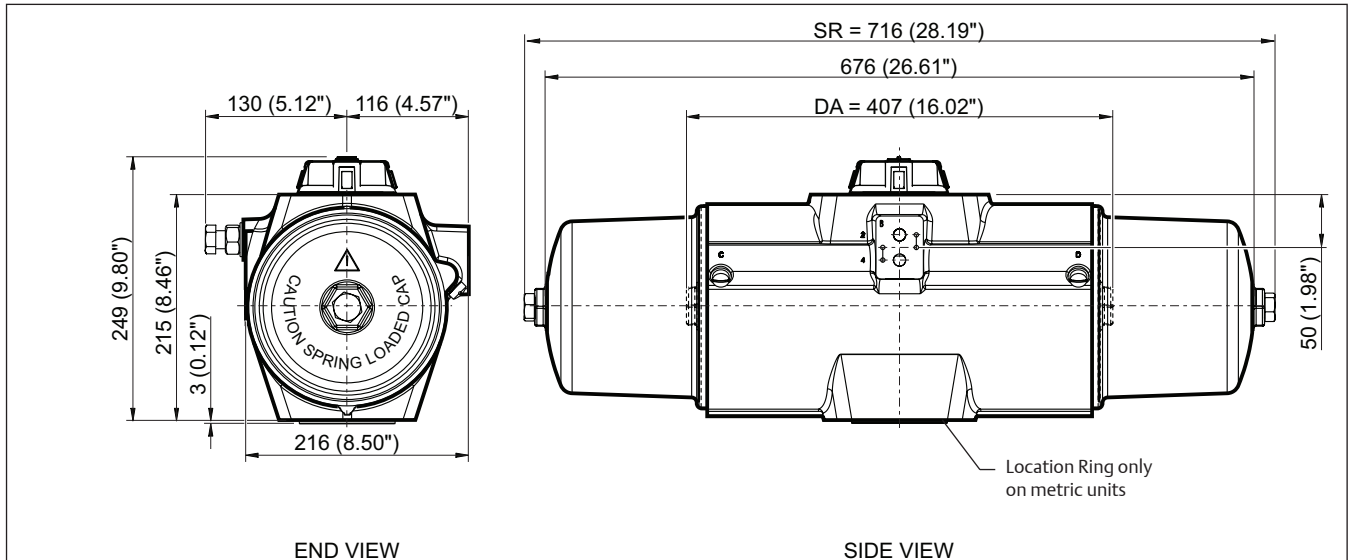

Torque in Nm, Pressure in bar(g)																
Double Acting Torques		529		705		882		970		1058		1234		1411		
Spring Rating	Torque From Springs		3.0 bar(g)		4.0 bar(g)		5.0 bar(g)		5.5 bar(g)		6.0 bar(g)		7.0 bar(g)		8.0 bar(g)	
	Start	End	Start	End	Start	End	Start	End	Start	End	Start	End	Start	End	Start	End
S40	304	183	346	225	523	401	699	577	787	665	875	753	1052	930	1228	1106
S50	381	228	301	148	477	325	653	501	741	589	830	677	1006	854	1182	1030
S60	457	274	255	72	431	249	608	425	696	513	784	601	960	778	1137	954
S70	533	320	-	-	386	172	562	349	650	437	738	525	915	701	1091	878
S80	609	365	-	-	340	96	516	273	605	361	693	449	869	625	1045	802
S90	685	411	-	-	-	-	471	197	559	285	647	373	823	549	1000	726
S1C	761	456	-	-	-	-	425	120	513	209	601	297	778	473	954	649

Torque in inch-pounds, Pressure in PSI																
Double Acting Torques		4275		5344		6413		8550		9619		10688		12825		
Spring Rating	Torque From Springs		40 PSI		50 PSI		60 PSI		80 PSI		90 PSI		100 PSI		120 PSI	
	Start	End	Start	End	Start	End	Start	End	Start	End	Start	End	Start	End	Start	End
S40	2694	1616	2659	1581	3728	2649	4797	3718	6934	5856	8003	6924	9072	7993	11209	10131
S50	3368	2020	2255	907	3324	1976	4393	3045	6530	5182	7599	6251	8668	7320	10805	9457
S60	4041	2424	-	-	2920	1302	3989	2371	6126	4509	7195	5577	8264	6646	10401	8784
S70	4715	2828	-	-	-	-	3585	1698	5722	3835	6791	4904	7860	5973	9997	8110
S80	5389	3232	-	-	-	-	3181	1024	5318	3161	6387	4230	7456	5299	9593	7436
S90	6062	3636	-	-	-	-	-	-	4914	2488	5983	3557	7052	4625	9189	6763
S1C	6736	4040	-	-	-	-	-	-	4510	1814	5579	2883	6648	3952	8785	6089

Envelope Dimensions and Torque Data

XL2586 Double acting and Spring Return actuator

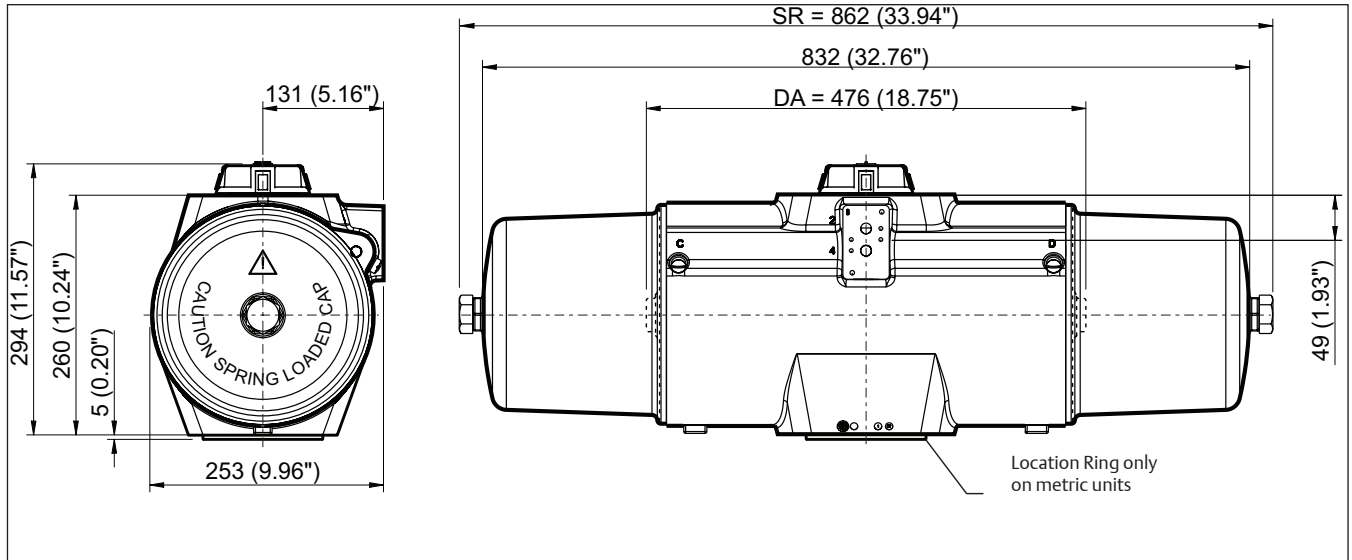

Torque in Nm, Pressure in bar(g)

Double Acting Torques		999		1332		1665		1832		1998		2331		2664		
Spring Rating	Torque From Springs		3.0 bar(g)		4.0 bar(g)		5.0 bar(g)		5.5 bar(g)		6.0 bar(g)		7.0 bar(g)		8.0 bar(g)	
	Start	End	Start	End	Start	End	Start	End	Start	End	Start	End	Start	End	Start	End
S40	574	345	654	425	987	758	1320	1091	1487	1257	1654	1424	1987	1757	2320	2090
S50	718	431	568	281	901	614	1234	947	1401	1114	1567	1280	1900	1613	2233	1946
S60	862	517	482	137	815	470	1148	803	1315	970	1481	1137	1814	1470	2147	1803
S70	1005	603	-	-	729	327	1062	660	1228	826	1395	993	1728	1326	2061	1659
S80	1149	689	-	-	643	183	976	516	1142	683	1309	849	1642	1182	1975	1515
S90	1293	776	-	-	-	-	890	373	1056	539	1223	706	1556	1039	1889	1372
S1C	1436	862	-	-	-	-	803	229	970	396	1136	562	1470	895	1803	1228

Torque in inch-pounds, Pressure in PSI

Double Acting Torques		8075		10094		12113		16150		18169		20188		24225		
Spring Rating	Torque From Springs		40 PSI		50 PSI		60 PSI		80 PSI		90 PSI		100 PSI		120 PSI	
	Start	End	Start	End	Start	End	Start	End	Start	End	Start	End	Start	End	Start	End
S40	5084	3051	5024	2991	7043	5010	9062	7028	13099	11066	15118	13085	17137	15103	21174	19141
S50	6355	3813	4262	1720	6281	3739	8299	5757	12337	9795	14356	11814	16374	13832	20412	17870
S60	7626	4576	-	-	5518	2468	7537	4486	11574	8524	13593	10543	15612	12561	19649	16599
S70	8897	5338	-	-	-	-	6774	3215	10812	7253	12830	9272	14849	11290	18887	15328
S80	10168	6101	-	-	-	-	6011	1944	10049	5982	12068	8001	14086	10019	18124	14057
S90	11439	6864	-	-	-	-	-	-	9286	4711	11305	6730	13324	8748	17361	12786
S1C	12710	7626	-	-	-	-	-	-	8524	3440	10542	5459	12561	7477	16599	11515

Envelope Dimensions and Torque Data

XL4581 Double acting and Spring Return actuator

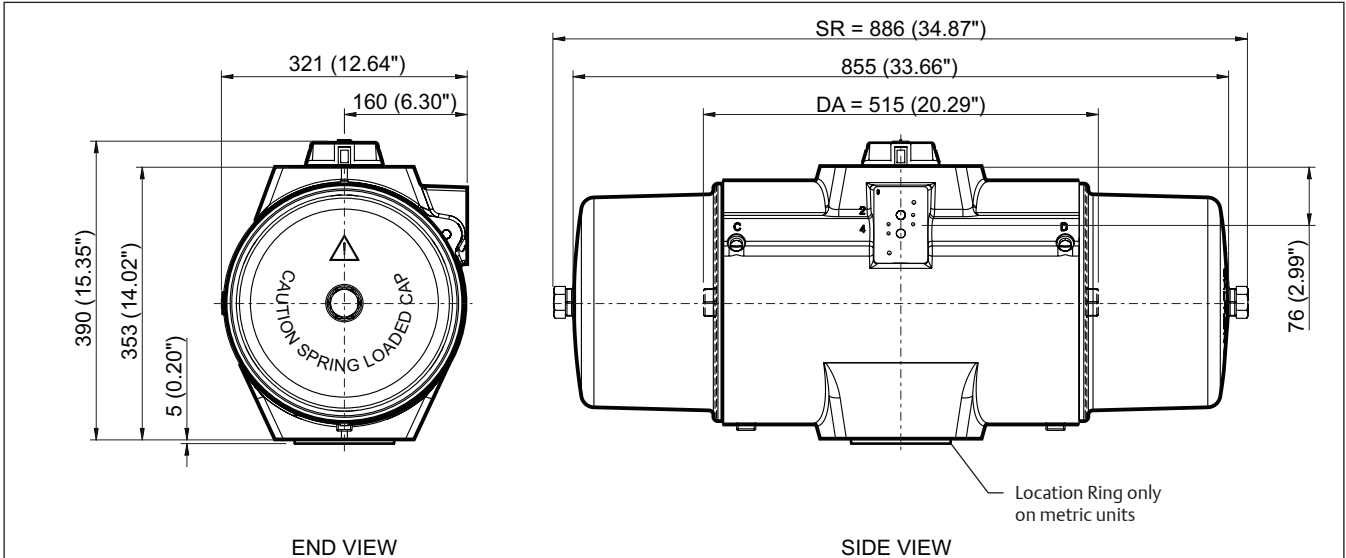

Torque in Nm, Pressure in bar(g)

Double Acting Torques		1763		2351		2939		3232		3526		4114		4702		
Spring Rating	Torque From Springs		3.0 bar(g)		4.0 bar(g)		5.0 bar(g)		5.5 bar(g)		6.0 bar(g)		7.0 bar(g)		8.0 bar(g)	
	Start	End	Start	End	Start	End	Start	End	Start	End	Start	End	Start	End	Start	End
S40	1017	610	1153	747	1741	1334	2329	1922	2623	2216	2916	2510	3504	3097	4092	3685
S50	1271	762	1001	492	1588	1080	2176	1668	2470	1962	2764	2256	3352	2843	3939	3431
S60	1525	915	848	238	1436	826	2024	1414	2318	1708	2611	2001	3199	2589	3787	3177
S70	1779	1067	-	-	1284	572	1871	1160	2165	1453	2459	1747	3047	2335	3634	2923
S80	2033	1220	-	-	1131	318	1719	905	2013	1199	2306	1493	2894	2081	3482	2669
S90	2287	1372	-	-	-	-	1566	651	1860	945	2154	1239	2742	1827	3329	2414
S1C	2541	1525	-	-	-	-	1414	397	1708	691	2001	985	2589	1573	3177	2160

Torque in inch-pounds, Pressure in PSI

Double Acting Torques		14250		17813		21375		28500		32063		35625		42750		
Spring Rating	Torque From Springs		40 PSI		50 PSI		60 PSI		80 PSI		90 PSI		100 PSI		120 PSI	
	Start	End	Start	End	Start	End	Start	End	Start	End	Start	End	Start	End	Start	End
S40	8996	5398	8852	5254	12415	8816	15977	12379	23102	19504	26665	23066	30227	26629	37352	33754
S50	11246	6747	7503	3004	11065	6567	14628	10129	21753	17254	25315	20817	28878	24379	36003	31504
S60	13495	8097	-	-	9716	4318	13278	7880	20403	15005	23966	18568	27528	22130	34653	29255
S70	15744	9446	-	-	-	-	11929	5631	19054	12756	22617	16319	26179	19881	33304	27006
S80	17993	10795	-	-	-	-	10580	3382	17705	10507	21267	14070	24830	17632	31955	24757
S90	20242	12145	-	-	-	-	-	-	16355	8258	19918	11821	23480	15383	30605	22508
S1C	22491	13494	-	-	-	-	-	-	15006	6009	18568	9571	22131	13134	29256	20259

World Area Configuration Centers (WACC) offer sales support, service, inventory and commissioning to our global customers.

Choose the WACC or sales office nearest you:

NORTH & SOUTH AMERICA

19200 Northwest Freeway
Houston TX 77065
USA
T +1 281 477 4100

Av. Hollingsworth
325 Iporanga Sorocaba
SP 18087-105
Brazil
T +55 15 3413 8888

ASIA PACIFIC

No. 9 Gul Road
#01-02 Singapore 629361
T +65 6777 8211

No. 1 Lai Yuan Road
Wuqing Development Area
Tianjin 301700
P. R. China
T +86 22 8212 3300

MIDDLE EAST & AFRICA

P. O. Box 17033
Jebel Ali Free Zone
Dubai
T +971 4 811 8100

P. O. Box 10305
Jubail 31961
Saudi Arabia
T +966 3 340 8650

24 Angus Crescent
Longmeadow Business Estate East
P.O. Box 6908 Greenstone
1616 Modderfontein Extension 5
South Africa
T +27 11 451 3700

EUROPE

Holland Faszor 6
Székesfehérvár 8000
Hungary
T +36 22 53 09 50

Strada Biffi 165
29017 Fiorenzuola d'Arda (PC)
Italy
T +39 0523 944 411

For complete list of sales and manufacturing sites, please visit www.emerson.com/actuationtechnologieslocations or contact us at info.actuationtechnologies@emerson.com

www.emerson.com/hytork

©2018 Emerson. All rights reserved.

The Emerson logo is a trademark and service mark of Emerson Electric Co. Hytork™ is a mark of one of the Emerson family of companies. All other marks are property of their respective owners.

The contents of this publication are presented for information purposes only, and while every effort has been made to ensure their accuracy, they are not to be construed as warranties or guarantees, express or implied, regarding the products or services described herein or their use or applicability. All sales are governed by our terms and conditions, which are available on request. We reserve the right to modify or improve the designs or specifications of our products at any time without notice.

HYTORK™

EMERSON™