

**Data sheet**

Date: Rev. 06/10  
DOC.DSB.CBB.PN

# Bettis CBB-Series

Technical data sheet - Imperial and Metric

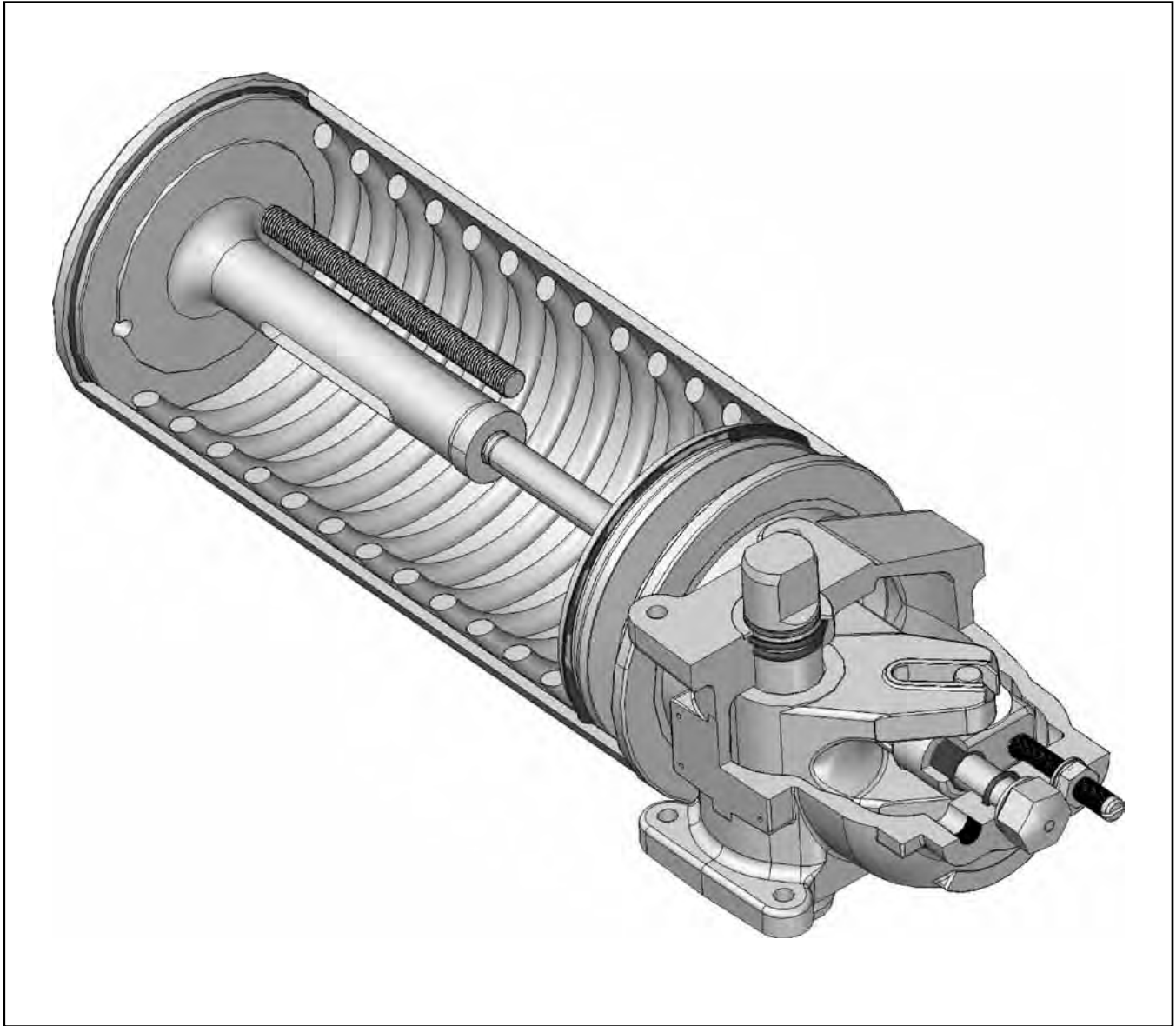

## Data sheet

Sheet No.: CBPI 1.01 RevB

Date: February 2010

# CBB-Series

# Torque Ratings – (Pneumatic)

All Published Torques are Guaranteed Minimum Values.

### Double-Acting Actuators

#### CBB-Series

Actuator Model	See Bettis' Definitions	Operating Pressure (PSIG)							
		40	50	60	70	80	90	100	120
		Pressure Torque Output Start/Min./End (lb-in)							
CBB 315	Start/End	678	848	1017	1187	1356	1526	1695	2034
	Minimum	404	505	606	707	808	910	1011	1213
CBB 420	Start/End	1536	1921	2305	2689	3073	3457	3841	4609
	Minimum	871	1089	1307	1525	1743	1961	2179	2614
CBB 520	Start/End	2133	2666	3200	3733				
	Minimum	1302	1628	1954	2279				
CBB 525	Start/End	2944	3680	4416	5152	5888	6624	7361	8833
	Minimum	1720	2150	2580	3009	3439	3869	4299	5159
CBB725	Start/End	5757	7197	8636	10075	11515			
	Minimum	3434	4292	5151	6009	6868			

### Spring-Return Actuators

#### CBB-Series

Actuator Model	Spring Torque Start/Min./End (lb-in)		Operating Pressure (PSIG)								
			40	50	60	70	80	90	100	120	150
			Pressure Torque Output Start/Min./End (lb-in)								
CBB315 SR40	Start	350	375	531	688	844	1000	1157	1313	1626	2095
	Min.	151	158	247	336	424	512	600	688	864	1128
	End	202	216	377	538	698	859	1020	1181	1502	1985
CBB315 SR60	Start	598		438	608	778	948	1117	1287	1627	2136
	Min.	238		153	249	343	436	530	623	808	1085
	End	305		172	342	512	681	851	1021	1360	1870
CBB315 SR80	Start	757				698	884	1069	1254	1625	2181
	Min.	306				237	328	418	509	689	958
	End	402				312	498	683	869	1239	1795
CBB315 SR100	Start	1069						876	1053	1406	1935
	Min.	405						331	428	621	906
	End	494						421	600	957	1493
Actuator Model	Spring Torque Start/Min./End (lb-in)		Pressure Torque Output Start/Min./End (lb-in)								
			40	50	60	70	80	90	100	120	150
			Operating Pressure (PSIG)								

# BETTIS™

www.Bettis.com

Copyright © Emerson Process Management. The information in this document is subject to change without notice.

Updated data sheets can be obtained from our website [www.bettis.com](http://www.bettis.com) or from your nearest Valve Automation Center.

USA: +1 281 727 5300 Europe: +31 74 256 1010 Asia-Pacific: +65 6501 4600



**EMERSON™**  
Process Management

**Data sheet**

Sheet No.: CBPI 1.02 RevB

Date: February 2010

**CBB-Series**

# Torque Ratings – (Pneumatic)

All Published Torques are Guaranteed Minimum Values.

**Spring-Return Actuators**

**CBB-Series (cont.)**

Actuator Model	SpringTorque Start/Min./End (lb-in)		Operating Pressure (PSIG)								
			40	50	60	70	80	90	100	120	150
			Pressure Torque Output Start/Min./End (lb-in)								
CBB415 SR40	Start	682	692	981	1271	1560	1850	2139	2429		
	Min.	284	285	451	614	778	941	1105	1268		
	End	365	387	701	1014	1328	1641	1955	2269		
CBB415 SR60	Start	1076		701	979	1256	1533	1811	2088		
	Min.	431		264	435	603	770	934	1099		
	End	577		294	600	905	1211	1516	1822		
CBB415 SR80	Start	1345				1077	1362	1648	1933		
	Min.	576				428	602	772	942		
	End	711				510	811	1113	1414		
CBB415 SR100	Start	1659						1701	2007		
	Min.	673						542	719		
	End	756						564	861		
CBB420 SR40	Start	591	844	1173	1501	1829	2157	2485	2813	3470	4454
	Min.	301	317	500	680	859	1037	1215	1393	1748	2282
	End	479	391	709	1028	1346	1665	1983	2302	2939	3894
CBB420 SR60	Start	1320			1333	1685	2037	2390	2742	3446	4503
	Min.	481			480	670	860	1048	1235	1607	2166
	End	691			562	871	1179	1488	1797	2415	3341
CBB420 SR80	Start	1661				1468	1825	2182	2539	3253	4325
	Min.	655				481	690	891	1088	1480	2068
	End	901				502	844	1187	1529	2215	3243
CBB520 SR40	Start	1004	1311	1805	2300	2794	3289	3783	4278		
	Min.	445	503	782	1056	1326	1596	1867	2137		
	End	562	677	1255	1834	2412	2990	3568	4146		
CBB520 SR60	Start	1719		1385	1895	2405	2914	3424	3934		
	Min.	747		484	794	1095	1390	1685	1980		
	End	966		509	1087	1665	2243	2821	3399		
CBB520 SR80	Start	2575				2133	2658	3183	3708	4757	
	Min.	1019				790	1111	1424	1734	2347	
	End	1243				893	1494	2095	2696	3898	
CBB520 SR100	Start	3880						2535	3067	4132	
	Min.	1361						855	1171	1773	
	End	1715						913	1491	2647	
CBB420 SR100	Start	2230						1958	2320	3044	4130
	Min.	836						643	857	1264	1859
	End	1119						674	1021	1716	2758
Actuator Model	SpringTorque Start/Min./End (lb-in)		Pressure Torque Output Start/Min./End (lb-in)								
			40	50	60	70	80	90	100	120	150
			Operating Pressure (PSIG)								



www.Bettis.com

Copyright © Emerson Process Management. The information in this document is subject to change without notice.

Updated data sheets can be obtained from our website [www.bettis.com](http://www.bettis.com) or from your nearest Valve Automation Center.

USA: +1 281 727 5300 Europe: +31 74 256 1010 Asia-Pacific: +65 6501 4600



**EMERSON**  
Process Management

**Data sheet**

Sheet No.: CBPI 1.03 RevB

Date: February 2010

**CBB-Series**

# Torque Ratings – (Pneumatic)

All Published Torques are Guaranteed Minimum Values.

**Spring-Return Actuators**

**CBB-Series (cont.)**

Actuator Model	SpringTorque Start/Min./End (lb-in)		Operating Pressure (PSIG)								
			40	50	60	70	80	90	100	120	150
			Pressure Torque Output Start/Min./End (lb-in)								
CBB525 SR40	Start	1652	1619	2310	3001	3692	4383	5074	5765	7147	
	Min.	608	638	993	1345	1698	2050	2402	2752	3452	
	End	949	946	1637	2328	3019	3710	4401	5092	6474	
CBB525 SR60	Start	2527		1849	2549	3250	3950	4651	5351	6752	8854
	Min.	983		632	1035	1425	1814	2198	2582	3348	4499
	End	1372		694	1404	2114	2824	3534	4244	5665	7795
CBB525 SR80	Start	3038				2732	3432	4133	4833	6234	8336
	Min.	1293				966	1363	1750	2138	2900	4042
	End	1680				1130	1859	2589	3318	4777	6965
CBB525 SR100	Start	4620						3673	4392	5832	7991
	Min.	1676						1369	1777	2581	3770
	End	2234						1696	2454	3970	6245
CBB725 SR40	Start	3148	3354	4780	6206	7632	9058	10484	11910		
	Min.	1283	1306	2048	2788	3520	4252	4984	5716		
	End	1641	1948	3488	5028	6568	8108	9648	11189		
CBB725 SR60	Start	5249		3467	4817	6167	7517	8867	10217		
	Min.	2106		1234	2080	2897	3709	4511	5313		
	End	2762		1284	2824	4364	5904	7444	8984		
CBB725 SR80	Start	7370				5064	6395	7726	9057	11719	
	Min.	2830				2018	2872	3706	4541	6189	
	End	3330				2326	3885	5444	7003	10122	
CBB725 SR100	Start	9482						7374	8781	11595	
	Min.	3260						2478	3279	4828	
	End	4269						2748	4250	7254	
Actuator Model	SpringTorque Start/Min./End (lb-in)		Pressure Torque Output Start/Min./End (lb-in)								
			40	50	60	70	80	90	100	120	150
			Operating Pressure (PSIG)								



www.Bettis.com

Copyright © Emerson Process Management. The information in this document is subject to change without notice.

Updated data sheets can be obtained from our website [www.bettis.com](http://www.bettis.com) or from your nearest Valve Automation Center.

USA: +1 281 727 5300 Europe: +31 74 256 1010 Asia-Pacific: +65 6501 4600



## Data sheet

Sheet No.: CBPM 1.01 RevB

Date: February 2010

# CBB-Series

## Torque Ratings – (Pneumatic)

All Published Torques are Guaranteed Minimum Values.

### Double-Acting Actuators

#### CBB-Series

Actuator Model	Stroke Position	Operating Pressure (Bar)							
		3	3.5	4	5	5.5	6	7	8
		Pressure Torque Output Start/Min./End (Nm)							
CBB 315	Start/End	83	97	111	139	153	167	194	222
	Minimum	50	58	66	83	91	99	116	133
CBB 420	Start/End	189	220	252	315	346	378	441	504
	Minimum	107	125	143	179	196	214	250	286
CBB 520	Start/End	262	306	350	437				
	Minimum	160	187	213	267				
CBB 525	Start/End	362	422	482	603	663	724	844	965
	Minimum	211	247	282	352	387	423	493	564
CBB725	Start/End	708	826	944	1179	1297			
	Minimum	422	492	563	703	774			

### Spring-Return Actuators

#### CBB-Series

Actuator Model	Spring Torque Start/Min./End (Nm)	Operating Pressure (Bar)										
		3	3.5	4	5	5.5	6	7	8	9	10	11
		Pressure Torque Output Start/Min./End (Nm)										
CBB315 SR40	Start	39	49	61	74	100	113	125	151	177	202	228
	Min.	17	21	29	36	51	58	65	79	94	108	123
	End	23	31	44	57	84	97	110	136	162	189	215
CBB315 SR60	Start	68	51	65	93	107	121	148	176	204	232	
	Min.	27	18	26	41	49	57	72	87	102	117	
	End	34	21	35	63	76	90	118	146	174	202	
CBB315 SR80	Start	86			84	99	115	145	175	206	236	
	Min.	35			29	37	44	59	74	89	103	
	End	45			41	56	71	101	132	162	192	
CBB315 SR100	Start	121					93	122	151	180	209	238
	Min.	46					34	50	66	81	97	113
	End	56					42	71	100	129	159	188
Actuator Model	Spring Torque Start/Min./End (Nm)	Pressure Torque Output Start/Min./End (Nm)										
		3	3.5	4	5	5.5	6	7	8	9	10	11
		Operating Pressure (Bar)										

# BETTIS™

www.Bettis.com

Copyright © Emerson Process Management. The information in this document is subject to change without notice.

Updated data sheets can be obtained from our website [www.bettis.com](http://www.bettis.com) or from your nearest Valve Automation Center.

USA: +1 281 727 5300 Europe: +31 74 256 1010 Asia-Pacific: +65 6501 4600



# EMERSON™

Process Management

**Data sheet**

Sheet No.: CBPM 1.02 RevB

Date: February 2010

**CBB-Series**

# Torque Ratings – (Pneumatic)

All Published Torques are Guaranteed Minimum Values.

**Spring-Return Actuators**

**CBB-Series (cont.)**

Actuator Model	Spring Torque Start/Min./End (Nm)		Operating Pressure (Bar)										
			3	3.5	4	5	5.5	6	7	8	9	10	11
			Pressure Torque Output Start/Min./End (Nm)										
CBB415 SR40	Start	77	90	113	137	185	208	232	279				
	Min.	32	39	52	66	93	106	119	146				
	End	41	56	82	108	159	185	210	262				
CBB415 SR60	Start	122		82	104	150	173	195	241				
	Min.	49		31	45	73	87	100	127				
	End	65		36	61	111	136	161	211				
CBB415 SR80	Start	152				130	153	176	223	270			
	Min.	65				53	68	82	109	137			
	End	80				66	91	116	165	214			
CBB415 SR100	Start	187						182	232				
	Min.	76						54	84				
	End	85						54	102				
CBB420 SR40	Start	67	108	135	162	216	243	270	324	377	431	485	
	Min.	34	43	58	73	102	117	131	160	190	219	248	
	End	54	57	83	109	161	187	213	266	318	370	422	
CBB420 SR60	Start	149			143	200	229	258	316	374	431	489	
	Min.	54			50	81	97	112	143	173	204	234	
	End	78			56	107	132	158	208	259	310	360	
CBB420 SR80	Start	188				176	205	235	293	352	410	469	527
	Min.	74				61	77	94	126	158	191	223	255
	End	102				66	94	123	179	235	291	347	403
CBB420 SR100	Start	252						209	268	328	387	446	506
	Min.	94						64	100	134	166	199	232
	End	126						64	121	178	235	292	349
CBB520 SR40	Start	113	168	208	249	330	370	411	492				
	Min.	50	68	91	113	158	180	202	246				
	End	64	99	147	194	289	336	384	478				
CBB520 SR60	Start	194		161	203	286	328	370	453	537			
	Min.	84		58	83	132	156	180	229	277			
	End	109		62	110	205	252	299	394	489			
CBB520 SR80	Start	291				256	299	342	428	514			
	Min.	115				98	125	150	201	251			
	End	140				118	167	216	315	413			
CBB520 SR100	Start	438						268	356	443	530		
	Min.	154						84	138	187	236		
	End	194						84	178	273	368		
Actuator Model	Spring Torque Start/Min./End (Nm)		Pressure Torque Output Start/Min./End (Nm)										
			3	3.5	4	5	5.5	6	7	8	9	10	11
			Operating Pressure (Bar)										



www.Bettis.com

Copyright © Emerson Process Management. The information in this document is subject to change without notice. Updated data sheets can be obtained from our website [www.bettis.com](http://www.bettis.com) or from your nearest Valve Automation Center. USA: +1 281 727 5300 Europe: +31 74 256 1010 Asia-Pacific: +65 6501 4600



**Data sheet**

Sheet No.: CBPM 1.03 RevB

Date: February 2010

**CBB-Series**

# Torque Ratings – (Pneumatic)

All Published Torques are Guaranteed Minimum Values.

**Spring-Return Actuators**

**CBB-Series (cont.)**

Actuator Model	Spring Torque Start/Min./End (Nm)	Operating Pressure (Bar)											
		3	3.5	4	5	5.5	6	7	8	9	10	11	
		Pressure Torque Output Start/Min./End (Nm)											
CBB525 SR40	Start	187	210	267	324	437	493	550	663	776	890	1003	
	Min.	69	86	115	144	202	231	260	317	374	432	489	
	End	107	134	191	248	361	417	474	587	700	814	927	
CBB525 SR60	Start	286		215	272	387	445	502	617	732	846	961	
	Min.	111		75	108	172	204	235	298	361	424	487	
	End	155		85	143	259	317	375	492	608	725	841	
CBB525 SR80	Start	343				329	386	443	558	673	788	903	1017
	Min.	146				121	153	185	248	311	373	435	498
	End	190				148	208	268	387	507	627	746	866
CBB525 SR100	Start	522						391	509	627	745	862	980
	Min.	189						141	208	274	339	404	469
	End	252						166	290	415	539	663	787
CBB725 SR40	Start	356	436	552	669	903	1020	1137	1370				
	Min.	145	175	236	297	419	479	539	658				
	End	185	281	407	534	786	912	1038	1291				
CBB725 SR60	Start	593		403	514	735	846	956	1178	1399			
	Min.	238		147	217	351	417	483	614	745			
	End	312		158	284	537	663	789	1042	1294			
CBB725 SR80	Start	833				610	719	828	1046	1264			
	Min.	320				253	322	391	527	662			
	End	376				307	435	563	818	1074			
CBB725 SR100	Start	1071						786	1016	1247			
	Min.	368						251	384	511			
	End	482						260	506	752			
Actuator Model	Spring Torque Start/Min./End (Nm)	Pressure Torque Output Start/Min./End (Nm)											
		3	3.5	4	5	5.5	6	7	8	9	10	11	
		Operating Pressure (Bar)											



www.Bettis.com

Copyright © Emerson Process Management. The information in this document is subject to change without notice. Updated data sheets can be obtained from our website [www.bettis.com](http://www.bettis.com) or from your nearest Valve Automation Center. USA: +1 281 727 5300 Europe: +31 74 256 1010 Asia-Pacific: +65 6501 4600



# Data sheet

Sheet No.: CBPI 2.01 RevB

Date: February 2010

CBB-Series

## Performance Data – (Pneumatic)

### Double-Acting Actuators CBB-Series

Actuator Model	Volume				Maximum Operating Pressure (MOP)*		Maximum Allowable Working Pressure (MAWP)**		Approximate Weight of Actuator	
	Outboard		Inboard (Housing)		PSIG	Bar	PSIG	Bar	Lbs.	Kg
	Cu. Inches	Cubic Cm	Cu. Inches	Cubic Cm						
CBB 315	24	393.3	54	885.0	120	8.3	200	13.8	20	9.1
CBB 420	53	868.5	115	1884.5	120	8.3	200	13.8	22	10.0
CBB 520	83	1360.1	148	2425.3	70	4.8	160	11.0	28	12.7
CBB 525	105	1720.6	207	3392.1	120	8.3	200	13.8	44	20.0
CBB 725	208	3408.5	327	5358.6	80	5.5	160	11.0	68	31.0

### Spring-Return Actuators CBB-Series

Actuator Model	Volume		Maximum Operating Pressure (MOP)*		Maximum Allowable Working Pressure (MAWP)**		Approximate Weight of Actuator	
	Cu. Inches	Cubic Cm	PSIG	Bar	PSIG	Bar	Lbs.	Kg
◆ CBB 315-SR40 SR60 SR80 SR100	54	885	155	10.7	200	13.8	22	10.0
	54	885	152	10.5	200	13.8	23	10.4
	54	885	150	10.3	200	13.8	26	11.8
	54	885	164	11.3	200	13.8	25	11.4
◆ CBB 415-SR40 SR60 SR80 SR100	75	1229	100	6.9	160	11.0	27	12.7
	75	1229	112	7.7	160	11.0	29	14.1
	75	1229	117	8.1	160	11.0	30	14.1
	75	1229	114	7.9	160	11.0	31	14.1
◆ CBB 420-SR40 SR60 SR80 SR100	115	1884.5	157	10.8	200	13.8	37	16.8
	115	1884.5	156	10.8	200	13.8	39	17.7
	115	1884.5	161	11.0	200	13.8	40	18.1
	115	1884.5	166	11.4	200	13.8	41	18.6
◆ CBB 520-SR40 SR60 SR80 SR100	148	2425.3	110	7.6	160	11.0	45	20.4
	148	2425.3	116	8.0	160	11.0	48	21.8
	148	2425.3	120	8.3	160	11.0	49	22.2
	148	2425.3	132	9.1	160	11.0	53	24.0
◆ CBB 525-SR40 SR60 SR80 SR100	207	3392	146	10.1	200	13.8	62	28.1
	207	3392	151	10.4	200	13.8	65	29.5
	207	3392	159	11.0	200	13.8	65	29.5
	207	3392	163	11.2	200	13.8	67	30.4
◆ CBB 725-SR40 SR60 SR80 SR100	327	5358.6	102	7.0	160	11.0	97	44.0
	327	5358.6	115	8.0	160	11.0	98	44.5
	327	5358.6	124	8.6	160	11.0	104	47.2
	327	5358.6	124	8.6	160	11.0	107	48.5

Notes:

- ◆ CBA-SRXXM mechanical handwheel overrides are available on these models. The override adds approximately 2 lbs. (.8 kg) to the weight of the standard CBA model.
  - ▲ Maximum volume including cavity required for calculating consumption per stroke.
  - \* **Maximum Operating Pressure (MOP)** is the pressure required to produce the maximum rated torque of the actuator.
  - \*\* **Maximum Allowable Working Pressure (MAWP)** is the maximum static pressure that may be applied to a fully stroked actuator against the travel stops.
- Standard installation produces clockwise rotation when the outboard side of piston is pressurized.  
 Standard installation produces counterclockwise rotation when the inboard side of piston is pressurized.  
 Note: Actuator may be installed opposite of that shown above

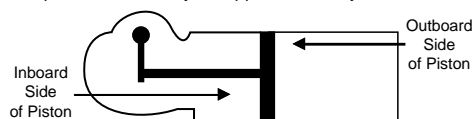

**BETTIS**<sup>™</sup>

www.Bettis.com

Copyright © Emerson Process Management. The information in this document is subject to change without notice.  
 Updated data sheets can be obtained from our website [www.bettis.com](http://www.bettis.com) or from your nearest Valve Automation Center.  
 USA: +1 281 727 5300 Europe: +31 74 256 1010 Asia-Pacific: +65 6501 4600

**EMERSON**<sup>™</sup>  
 Process Management



# Data sheet

Sheet No.: CBPI 3.01 RevB

Date: September 2010

CBB-Series

## Dimensions – (Pneumatic) In.

### Double-Acting Actuators CBBXXX

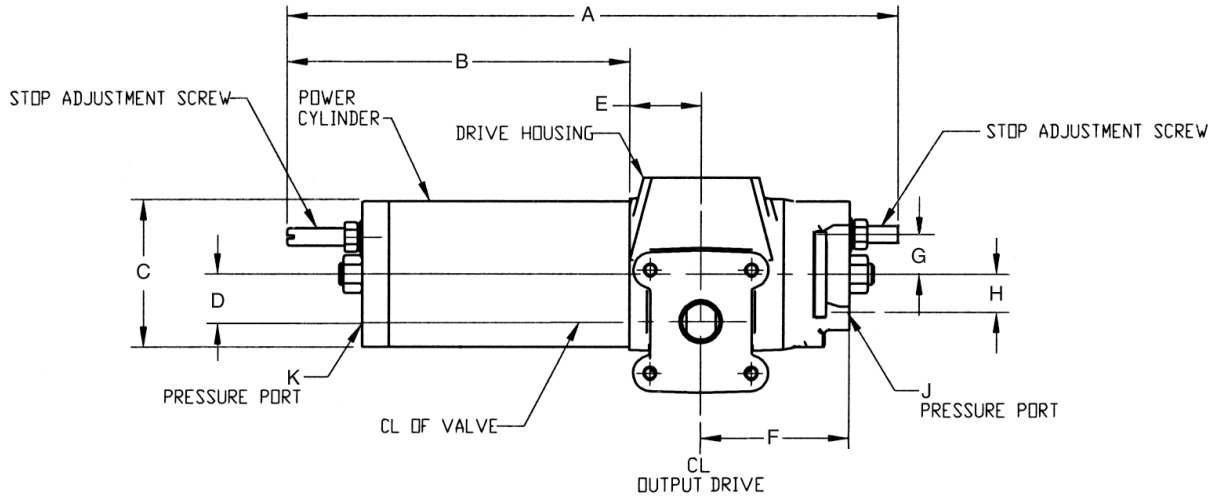

Actuator Model	A	B	C	D	E	F	G	H	J/K	L	M	N
CBB315	14.16	7.38	3.25	1.09	1.88	3.46	0.94	0.94	1/4" NPT	.313-18 UNC	0.38	2.250
CBB420	16.43	8.57	4.25	1.38	2.13	4.37	1.10	1.10	3/8" NPT	.375-16 UNC	0.50	3.000
CBB520	16.46	8.63	5.38	1.38	2.07	4.37	1.10	1.10	3/8" NPT	.375-16 UNC	0.50	3.000
CBB525	19.22	9.88	5.38	1.69	2.56	5.00	1.25	1.25	3/8" NPT	.500-13 UNC	0.50	3.500
CBB725	19.44	10.24	7.50	1.69	2.53	5.00	1.25	1.25	3/8" NPT	.500-13 UNC	0.50	3.500

Actuator Model	P	Q	R	S	T	U	V	W	X	Y	Z	AA
CBB315	.313-18 UNC	1.125	2.91	5.81	0.75	2.22	5.18	0.614 0.620	1.03	3.75	1.09	0.873 0.875
CBB420	.375-16 UNC	1.500	3.35	6.69	0.75	2.81	6.25	0.864 0.870	1.03	4.63	1.38	1.123 1.125
CBB520	.375-16 UNC	1.500	3.35	6.69	0.75	2.81	6.25	0.864 0.870	1.03	4.63	1.38	1.121 1.125
CBB525	.500-13 UNC	1.750	4.38	8.75	1.12	3.50	7.58	1.115 1.121	1.50	5.75	1.69	1.498 1.500
CBB725	.500-13 UNC	1.750	4.38	8.75	1.12	3.50	7.58	1.115 1.121	1.50	5.75	1.69	1.498 1.500

Note: Not Certified dimensional drawings. Such drawings available on request.  
Contact factory with correct model designation and serial number.  
All dimensions are expressed in inches.

**BETTIS**<sup>™</sup>

www.Bettis.com

Copyright © Emerson Process Management. The information in this document is subject to change without notice.  
Updated data sheets can be obtained from our website [www.bettis.com](http://www.bettis.com) or from your nearest Valve Automation Center.  
USA: +1 281 727 5300 Europe: +31 74 256 1010 Asia-Pacific: +65 6501 4600

  
**EMERSON**<sup>™</sup>  
Process Management

# Data sheet

Sheet No.: CBPI 3.02 RevB

Date: September 2010

# CBB-Series

## Dimensions – (Pneumatic) In.

Double-Acting Actuators  
CBBXXX (cont.)

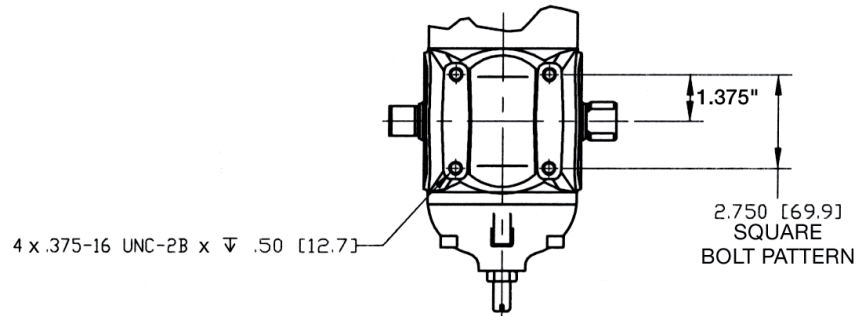

ACTUATORS SHOWN ROTATED  
TO FULL CLOCKWISE POSITION

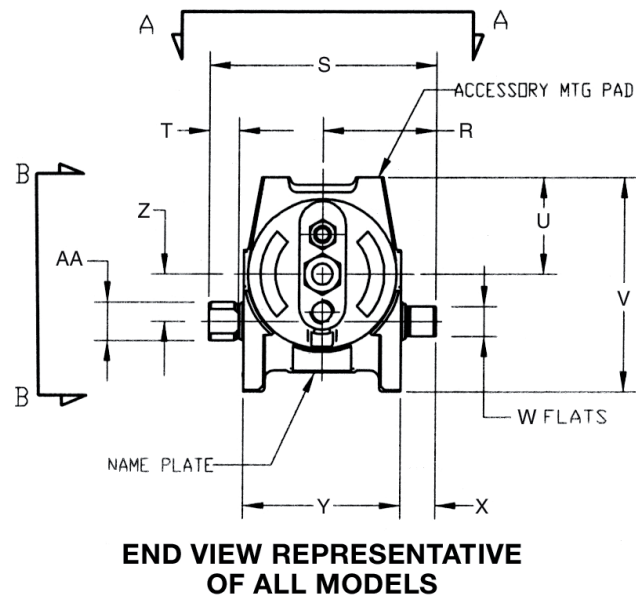
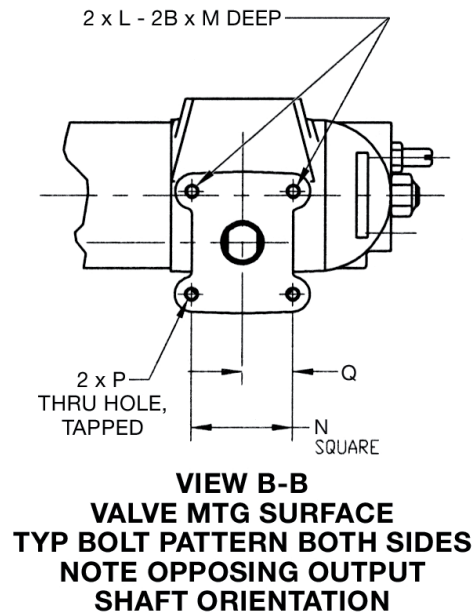

Note: Not Certified dimensional drawings. Such drawings available on request.  
Contact factory with correct model designation and serial number.  
All dimensions are expressed in inches.

# BETTIS™

www.Bettis.com

Copyright © Emerson Process Management. The information in this document is subject to change without notice.  
Updated data sheets can be obtained from our website [www.bettis.com](http://www.bettis.com) or from your nearest Valve Automation Center.  
USA: +1 281 727 5300 Europe: +31 74 256 1010 Asia-Pacific: +65 6501 4600

**EMERSON™**  
Process Management

# Data sheet

Sheet No.: CBPI 3.03 Rev D

Date: January 2013

CBB-Series

## Dimensions – (Pneumatic) In.

### Spring-Return Actuators CBB XXX-SRX

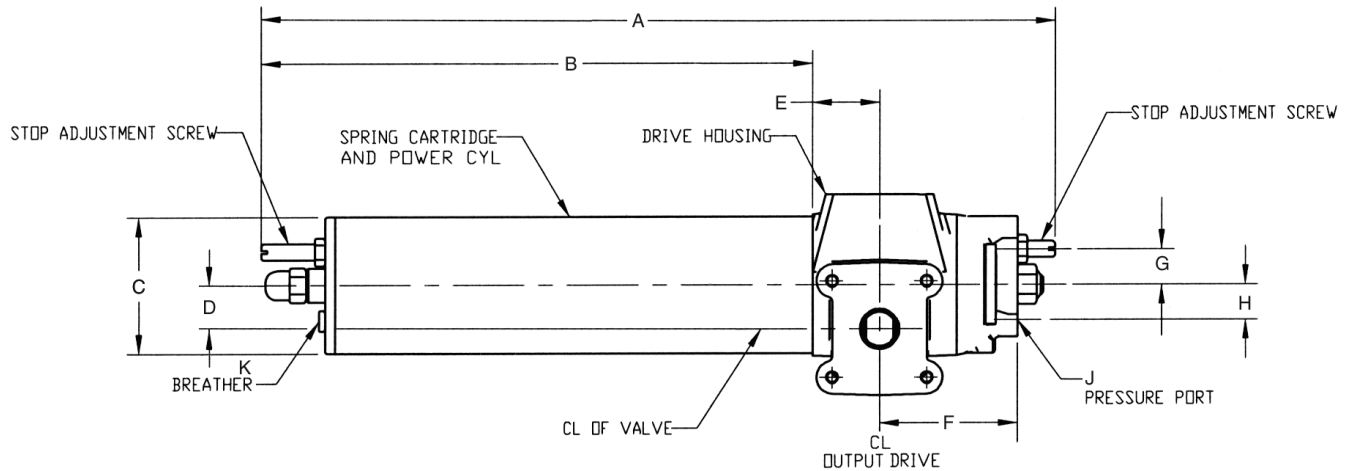

Actuator Model	A	B	C	D	E	F	G	H	J	K	L
CBB315-SRX	20.13	13.66	3.25	1.09	1.88	3.46	0.94	0.94	1/4" NPT	1/4" NPT	.313-18 UNC
CBB415-SRX	20.20	13.71	4.25	1.09	1.88	3.46	0.94	0.94	1/4" NPT	1/4" NPT	.313-18 UNC
CBB420-SRX	24.54	17.07	4.25	1.38	2.13	4.37	1.10	1.10	3/8" NPT	1/4" NPT	.375-16 UNC
CBB520-SRX	24.88	17.44	5.38	1.38	2.07	4.37	1.10	1.10	3/8" NPT	1/4" NPT	.375-16 UNC
CBB525-SRX	28.21	18.01	5.38	1.69	2.56	5.00	1.25	1.25	3/8" NPT	1/4" NPT	.500-13 UNC
CBB725-SRX	28.09	18.37	7.50	1.69	2.53	5.00	1.25	1.25	3/8" NPT	1/4" NPT	.500-13 UNC

Actuator Model	M	N	P	Q	R	S	T	U	V	W	X	Y	Z	AA
CBB315-SRX	0.38	2.250	.313-18 UNC	1.125	2.91	5.81	0.75	2.22	5.18	0.614 0.620	1.03	3.75	1.09	0.873 0.875
CBB415-SRX	0.38	2.250	.313-18 UNC	1.125	2.91	5.81	0.75	2.22	5.18	0.614 0.620	1.03	3.75	1.09	0.871 0.875
CBB420-SRX	0.50	3.000	.375 -16 UNC	1.500	3.35	6.69	0.75	2.81	6.25	0.864 0.870	1.03	4.63	1.38	1.123 1.125
CBB520-SRX	0.50	3.000	.375 -16 UNC	1.500	3.35	6.69	0.75	2.81	6.25	0.864 0.870	1.03	4.63	1.38	1.121 1.125
CBB525-SRX	0.50	3.500	.500 -13 UNC	1.750	4.38	8.75	1.12	3.50	7.58	1.115 1.121	1.50	5.75	1.69	1.498 1.500
CBB725-SRX	0.50	3.500	.500 -13 UNC	1.750	4.38	8.75	1.12	3.50	7.58	1.115 1.121	1.50	5.75	1.69	1.498 1.500

Note: Not Certified dimensional drawings. Such drawings available on request.  
Contact factory with correct model designation and serial number.  
All dimensions are expressed in inches.

**BETTIS**<sup>TM</sup>

www.Bettis.com

Copyright © Emerson Process Management. The information in this document is subject to change without notice.  
Updated data sheets can be obtained from our website [www.bettis.com](http://www.bettis.com) or from your nearest Valve Automation Center.  
USA: +1 281 727 5300 Europe: +31 74 256 1010 Asia-Pacific: +65 6501 4600

  
**EMERSON**<sup>TM</sup>  
Process Management

**Data sheet**

Sheet No.: CBPI 3.04 RevB

Date: September 2010

**CBB-Series**

# Dimensions – (Pneumatic) In.

**Spring-Return Actuators**

**CBB XXX-SRX (cont.)**

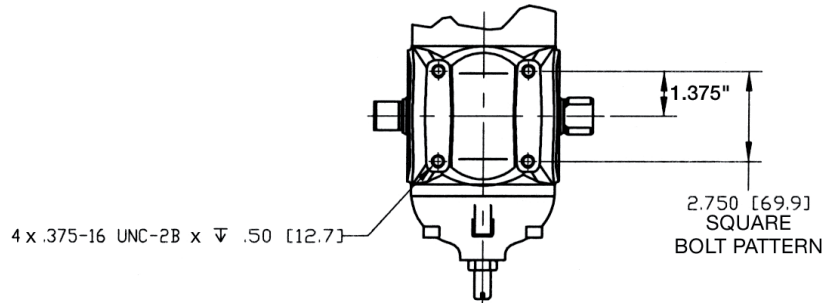

ACTUATORS SHOWN ROTATED TO FULL CLOCKWISE POSITION

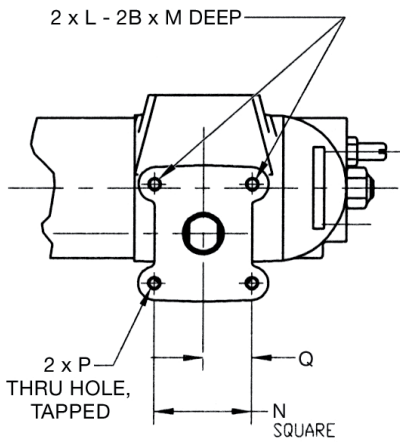

**VIEW B-B**  
**VALVE MTG SURFACE**  
**TYP BOLT PATTERN BOTH SIDES**  
**NOTE OPPOSING OUTPUT**  
**SHAFT ORIENTATION**

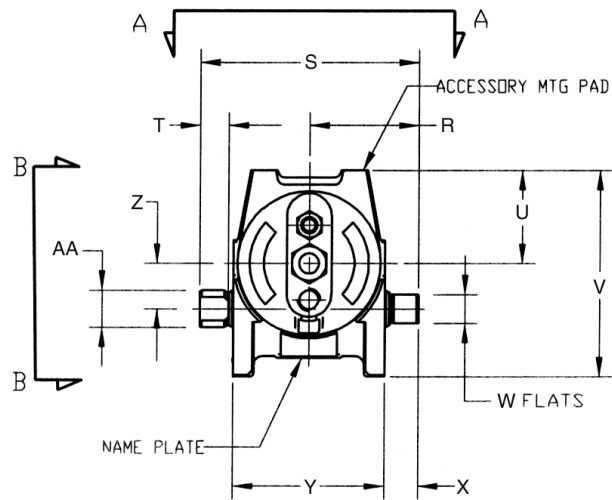

**END VIEW REPRESENTATIVE**  
**OF ALL MODELS**

Note: Not Certified dimensional drawings. Such drawings available on request.  
Contact factory with correct model designation and serial number.  
All dimensions are expressed in inches.



www.Bettis.com

Copyright © Emerson Process Management. The information in this document is subject to change without notice.  
Updated data sheets can be obtained from our website [www.bettis.com](http://www.bettis.com) or from your nearest Valve Automation Center.  
USA: +1 281 727 5300 Europe: +31 74 256 1010 Asia-Pacific: +65 6501 4600



# Data sheet

Sheet No.: CBPI 3.05 RevB

Date: September 2010

CBB-Series

## Dimensions – (Pneumatic) In.

### M3(HW) Override

Double-Acting Actuators

CBB XXX-M3(HW)

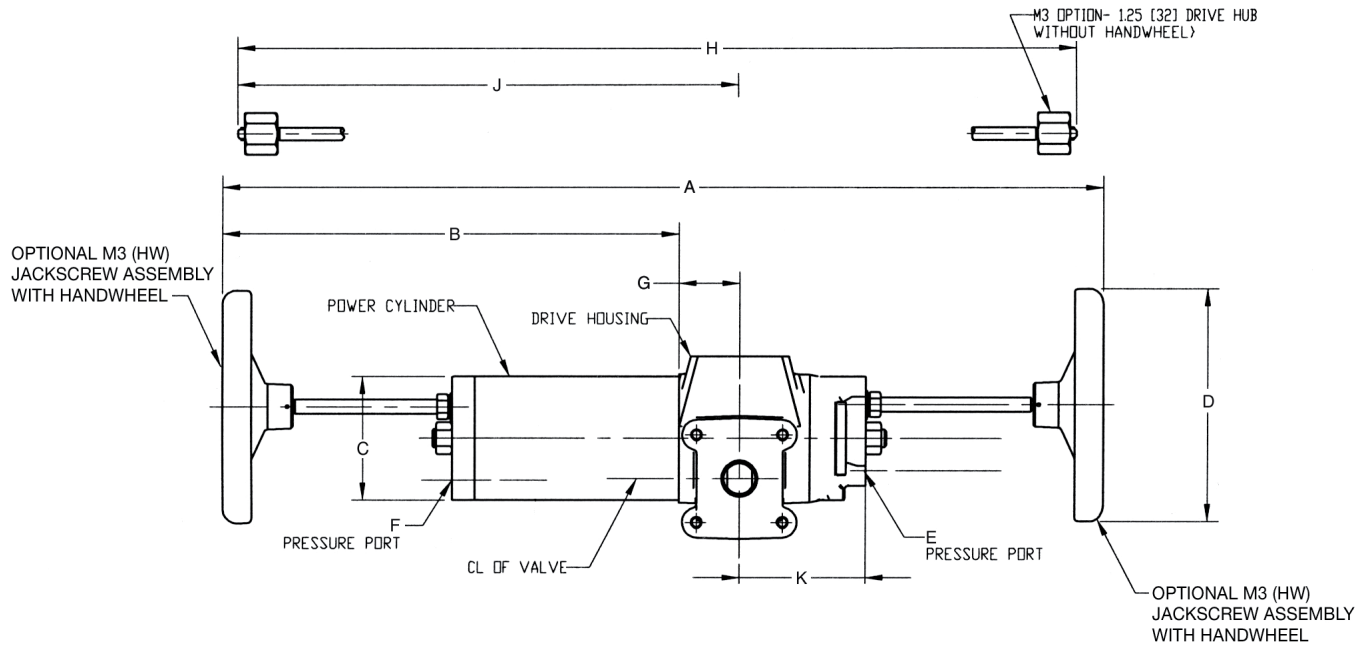

Actuator Model	A	B	C	D	E	F	G	H	J	K
CBB315-M3HW	25.23	13.01	3.25	6.00	1/4" NPT	1/4" NPT	1.88	24.21	14.37	3.47
CBB420-M3HW	30.58	15.82	4.25	8.00	3/8" NPT	3/8" NPT	2.13	29.12	17.37	4.38
CBB520-M3HW	30.58	15.85	5.25	8.00	3/8" NPT	3/8" NPT	2.09	29.06	17.37	4.38
CBB525-M3HW	36.52	18.92	5.25	10.00	3/8" NPT	3/8" NPT	2.56	34.17	20.31	5.00
CBB725-M3HW	36.65	19.08	7.50	10.00	3/8" NPT	3/8" NPT	2.53	34.17	20.31	5.00

Note: Not Certified dimensional drawings. Such drawings available on request.  
 Contact factory with correct model designation and serial number.  
 All dimensions are expressed in inches.

**BETTIS**<sup>™</sup>

www.Bettis.com

Copyright © Emerson Process Management. The information in this document is subject to change without notice.  
 Updated data sheets can be obtained from our website [www.bettis.com](http://www.bettis.com) or from your nearest Valve Automation Center.  
 USA: +1 281 727 5300 Europe: +31 74 256 1010 Asia-Pacific: +65 6501 4600

  
**EMERSON**<sup>™</sup>  
 Process Management

# Data sheet

Sheet No.: CBPI 3.06 RevB

Date: September 2010

CBB-Series

## Dimensions – (Pneumatic) In.

### M3(HW) Override

#### Spring-Return Actuators

#### CBB XXX-SRX-M3

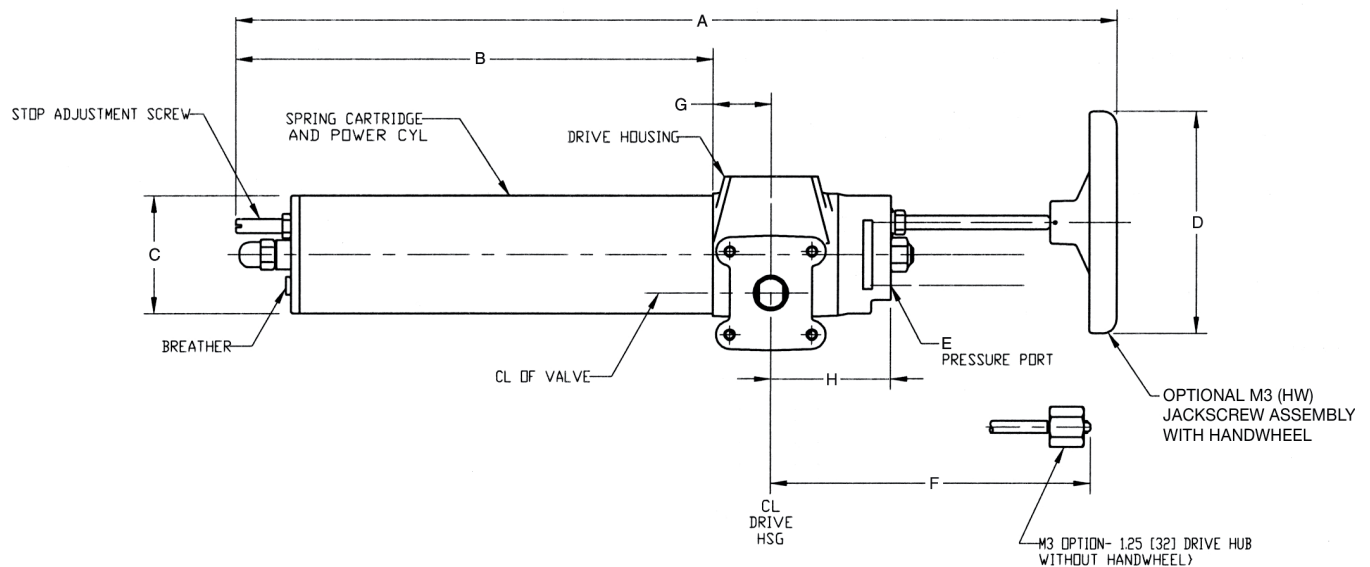

Actuator Model	A	B	C	D	E	F	G	H
CBB315-SR-M3HW	26.66	14.43	3.25	6.00	1/4" NPT	9.84	1.88	3.47
CBB415-SR-M3HW	26.74	14.51	4.25	6.00	1/4" NPT	9.84	1.88	3.47
CBB420-SR-M3HW	32.13	17.37	4.25	8.00	3/8" NPT	11.69	2.13	4.38
CBB420-SR-M3HW	32.16	17.43	5.38	8.00	3/8" NPT	11.69	2.09	4.38
CBB525-SR-M3HW	36.93	19.33	5.38	10.00	3/8" NPT	13.86	2.56	5.00
CBB725-SR-M3HW	36.98	19.41	7.50	10.00	3/8" NPT	13.86	2.53	5.00

Note: Not Certified dimensional drawings. Such drawings available on request.  
 Contact factory with correct model designation and serial number.  
 All dimensions are expressed in inches.

**BETTIS**<sup>™</sup>

www.Bettis.com

Copyright © Emerson Process Management. The information in this document is subject to change without notice.  
 Updated data sheets can be obtained from our website [www.bettis.com](http://www.bettis.com) or from your nearest Valve Automation Center.  
 USA: +1 281 727 5300 Europe: +31 74 256 1010 Asia-Pacific: +65 6501 4600

**EMERSON**<sup>™</sup>  
 Process Management

# Data sheet

Sheet No.: CBPM 3.01 Rev D  
Date: August 2012

CBB-Series

## Dimensions – (Pneumatic) mm.

### Double-Acting Actuators CBBXXX

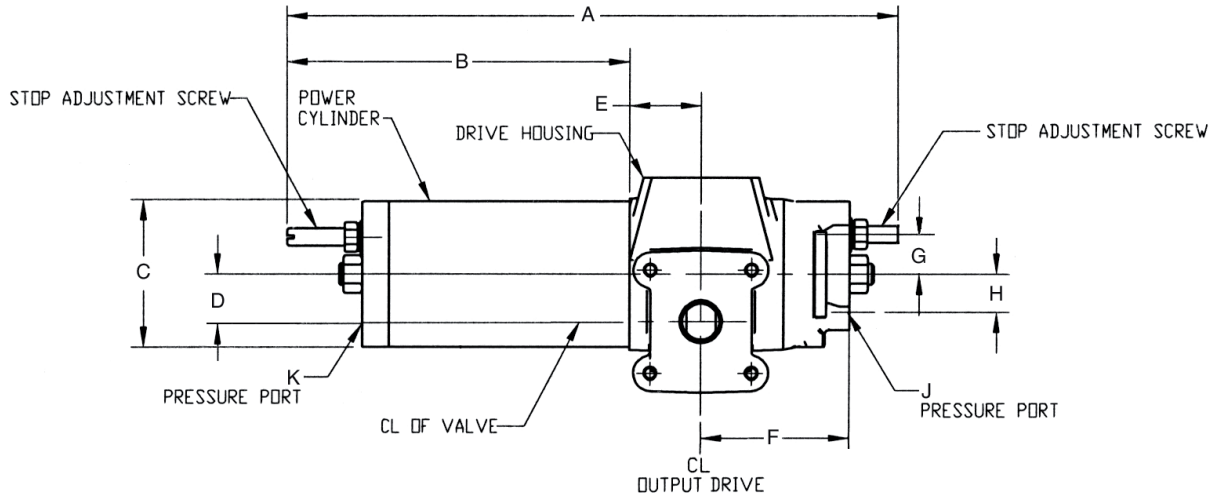

Actuator Model	A	B	C	D	E	F	G	H	J/K	L	M	N
CBB315	359.8	187.5	82.6	27.8	47.8	87.8	23.8	23.9	1/4" NPT	.313-18 UNC	9.7	57.2
CBB420	417.3	217.6	108.0	34.9	54.1	111.0	27.9	27.9	3/8" NPT	.375-16 UNC	12.7	76.2
CBB520	418.1	219.2	136.7	34.9	53.5	111.0	27.9	27.9	3/8" NPT	.375-16 UNC	12.7	76.2
CBB525	488.1	250.9	136.7	42.9	65.0	127.0	31.8	28.4	3/8" NPT	.500-13 UNC	12.7	88.9
CBB725	492.7	260.1	190.5	42.9	64.2	127.0	31.8	28.4	3/8" NPT	.500-13 UNC	12.7	88.9

Actuator Model	P	Q	R	S	T	U	V	W	X	Y	Z	AA
CBB315	.313-18 UNC	28.6	73.8	147.6	19.1	56.4	131.5	15.60 15.75	26.2	95.3	27.8	22.17 22.23
CBB420	.375-16 UNC	38.1	85.1	169.9	19.1	71.3	158.9	21.95 22.10	26.2	117.5	35.1	28.52 28.58
CBB520	.375-16 UNC	38.1	85.1	169.9	19.1	71.3	158.9	21.95 22.10	26.2	117.5	35.1	28.52 28.58
CBB525	.500-13 UNC	44.5	111.1	222.3	28.4	88.9	192.6	28.32 28.47	38.1	146.1	42.9	38.05 38.10
CBB725	.500-13 UNC	44.5	111.1	222.3	28.4	88.9	192.6	28.32 28.47	38.1	146.1	42.9	38.05 38.10

Note: Not Certified dimensional drawings. Such drawings available on request.  
Contact factory with correct model designation and serial number.  
All dimensions are expressed in millimeters.

**BETTIS**<sup>™</sup>

www.Bettis.com

Copyright © Emerson Process Management. The information in this document is subject to change without notice.  
Updated data sheets can be obtained from our website [www.bettis.com](http://www.bettis.com) or from your nearest Valve Automation Center.  
USA: +1 281 727 5300 Europe: +31 74 256 1010 Asia-Pacific: +65 6501 4600

  
**EMERSON**<sup>™</sup>  
Process Management

# Data sheet

Sheet No.: CBPM 3.02 RevC

Date: September 2011

CBB-Series

## Dimensions – (Pneumatic) mm.

Double-Acting Actuators  
CBBXXX (cont.)

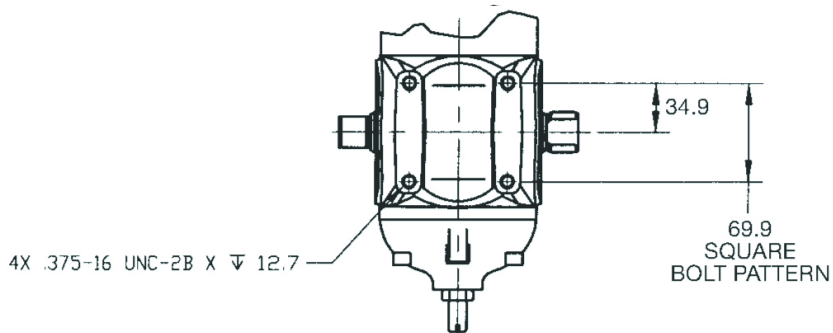

ACTUATORS SHOWN ROTATED  
TO FULL CLOCKWISE POSITION

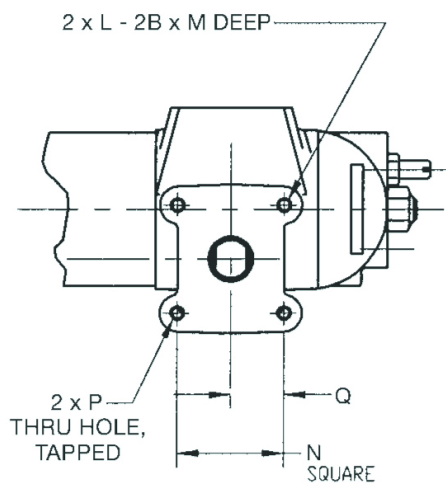

**VIEW B-B**  
VALVE MTG SURFACE  
TYP BOLT PATTERN BOTH SIDES  
NOTE OPPOSING OUTPUT  
SHAFT ORIENTATION

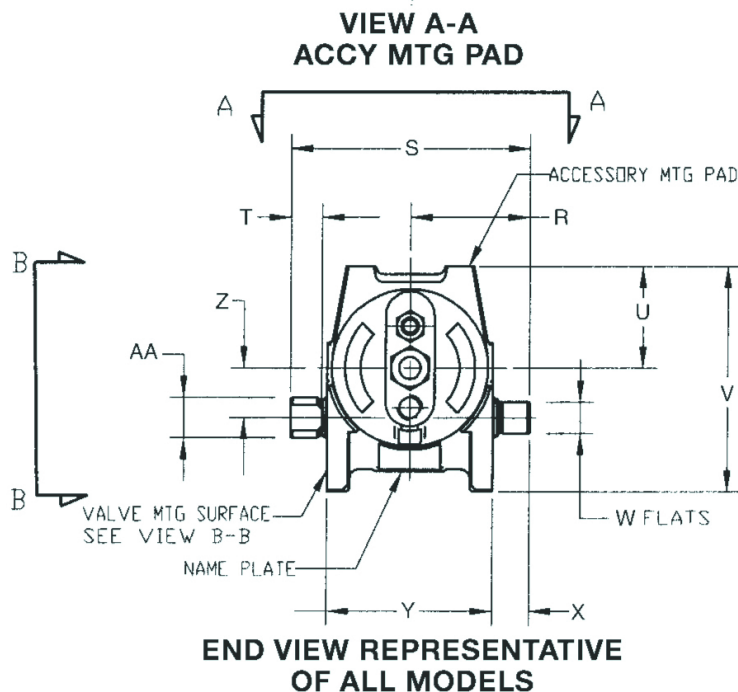

**END VIEW REPRESENTATIVE  
OF ALL MODELS**

Note: Not Certified dimensional drawings. Such drawings available on request.  
Contact factory with correct model designation and serial number.  
All dimensions are expressed in millimeters.

**BETTIS**<sup>™</sup>

www.Bettis.com

Copyright © Emerson Process Management. The information in this document is subject to change without notice.  
Updated data sheets can be obtained from our website [www.bettis.com](http://www.bettis.com) or from your nearest Valve Automation Center.  
USA: +1 281 727 5300 Europe: +31 74 256 1010 Asia-Pacific: +65 6501 4600

**EMERSON**<sup>™</sup>  
Process Management



# Data sheet

Sheet No.: CBPM 3.03 Rev E

Date: January 2013

# CBB-Series

## Dimensions – (Pneumatic) mm.

### Spring-Return Actuators CBB XXX-SRX

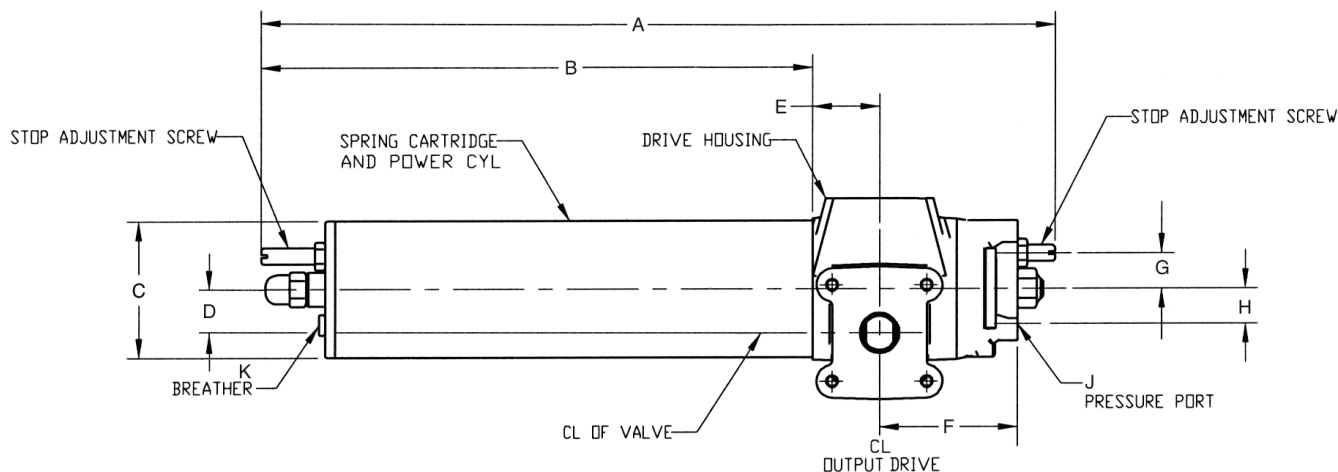

Actuator Model	A	B	C	D	E	F	G	H	J	K	L
CBB315-SRX	511.2	347.0	82.6	27.8	47.8	87.8	23.8	23.9	1/4" NPT	1/4" NPT	.313-18 UNC
CBB415-SRX	513.3	348.2	108.0	27.8	47.8	87.8	23.9	23.9	1/4" NPT	1/4" NPT	.313-18 UNC
CBB420-SRX	623.3	433.5	108.0	34.9	54.1	111.0	27.9	27.9	3/8" NPT	1/4" NPT	.375-16 UNC
CBB520-SRX	631.9	442.9	136.7	34.9	52.2	111.0	27.9	27.9	3/8" NPT	1/4" NPT	.375-16 UNC
CBB525-SRX	716.6	457.4	136.7	42.9	65.0	127.0	31.8	28.4	3/8" NPT	1/4" NPT	.500-13 UNC
CBB725-SRX	713.6	466.7	190.5	42.9	64.2	127.0	31.8	28.4	3/8" NPT	1/4" NPT	.500-13 UNC

Actuator Model	M	N	P	Q	R	S	T	U	V	W	X	Y	Z	AA
CBB315-SRX	9.7	57.2	.313-18 UNC	28.6	73.8	147.6	19.1	56.4	131.5	15.60 15.75	26.2	95.3	27.8	22.17 22.23
CBB415-SRX	9.7	57.2	.313-18 UNC	28.6	73.8	147.6	19.1	56.4	131.5	15.60 15.75	26.2	95.3	27.8	22.17 22.23
CBB420-SRX	12.7	76.2	.375-16 UNC	38.1	85.1	169.9	19.1	71.3	158.9	21.95 22.10	26.2	117.5	35.1	28.52 28.58
CBB520-SRX	12.7	76.2	.375-16 UNC	38.1	85.1	169.9	19.1	71.3	158.9	21.95 22.10	26.2	117.5	35.1	28.52 28.58
CBB525-SRX	12.7	88.9	.500-13 UNC	44.5	111.1	222.3	28.4	88.9	192.6	28.32 28.47	38.1	146.1	42.9	38.05 38.10
CBB725-SRX	12.7	88.9	.500-13 UNC	44.5	111.1	222.3	28.4	88.9	192.6	28.32 28.47	38.1	146.1	42.9	38.05 38.10

Note: Not Certified dimensional drawings. Such drawings available on request.  
Contact factory with correct model designation and serial number.  
All dimensions are expressed in millimeters.

# BETTIS™

www.Bettis.com

Copyright © Emerson Process Management. The information in this document is subject to change without notice.  
Updated data sheets can be obtained from our website [www.bettis.com](http://www.bettis.com) or from your nearest Valve Automation Center.  
USA: +1 281 727 5300 Europe: +31 74 256 1010 Asia-Pacific: +65 6501 4600



# EMERSON™

Process Management

# Data sheet

Sheet No.: CBPM 3.04 RevC

Date: September 2011

# CBB-Series

## Dimensions – (Pneumatic) mm.

### Spring-Return Actuators

CBB XXX-SRX (cont.)

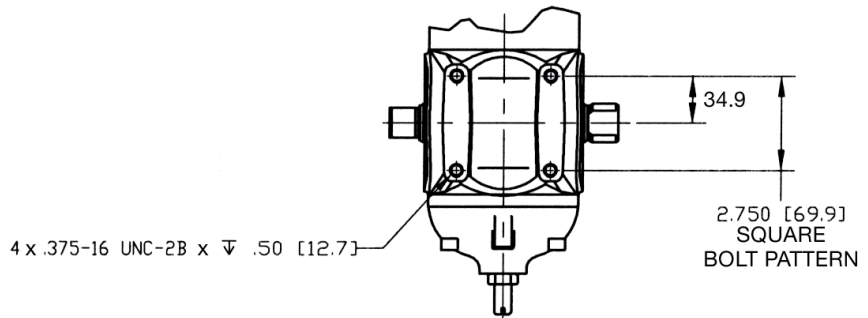

ACTUATORS SHOWN ROTATED TO FULL CLOCKWISE POSITION

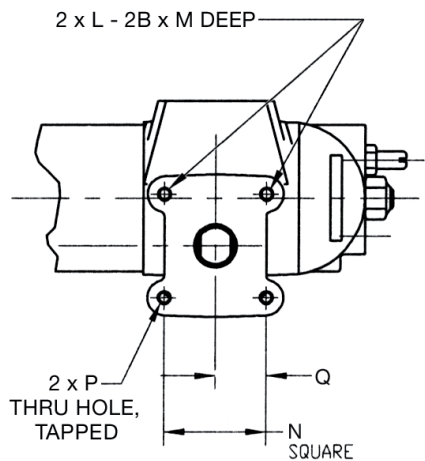

**VIEW B-B**  
**VALVE MTG SURFACE**  
**TYP BOLT PATTERN BOTH SIDES**  
**NOTE OPPOSING OUTPUT**  
**SHAFT ORIENTATION**

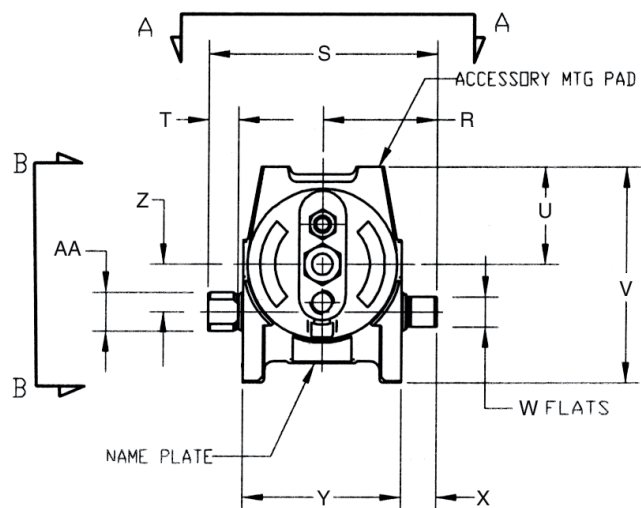

**END VIEW REPRESENTATIVE**  
**OF ALL MODELS**

Note: Not Certified dimensional drawings. Such drawings available on request.  
Contact factory with correct model designation and serial number.  
All dimensions are expressed in millimeters.

# BETTIS™

www.Bettis.com

Copyright © Emerson Process Management. The information in this document is subject to change without notice.  
Updated data sheets can be obtained from our website [www.bettis.com](http://www.bettis.com) or from your nearest Valve Automation Center.  
USA: +1 281 727 5300 Europe: +31 74 256 1010 Asia-Pacific: +65 6501 4600

**EMERSON™**  
Process Management

# Data sheet

Sheet No.: CBPM 3.05 RevC

Date: September 2011

CBB-Series

## Dimensions – (Pneumatic) mm.

### M3(HW) Override

Double-Acting Actuators

CBB XXX-M3(HW)

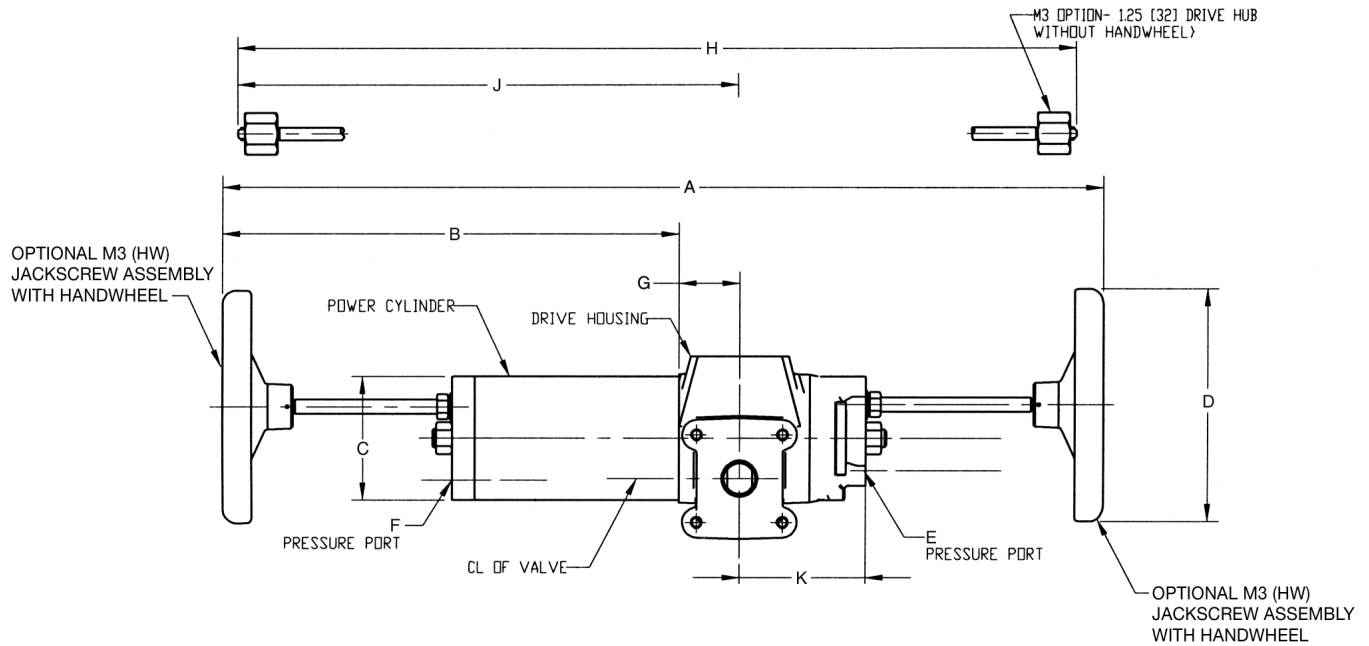

Actuator Model	A	B	C	D	E	F	G	H	J	K
CBB315-M3HW	640.8	365.0	82.6	152.4	1/4" NPT	1/4" NPT	47.6	614.9	365.0	88.2
CBB420-M3HW	776.8	401.8	108.0	203.2	3/8" NPT	3/8" NPT	54.0	739.6	441.1	111.1
CBB520-M3HW	776.8	402.5	133.4	203.2	3/8" NPT	3/8" NPT	53.2	738.0	441.1	111.1
CBB525-M3HW	927.5	480.5	133.4	254.0	3/8" NPT	3/8" NPT	65.0	867.9	515.8	127.0
CBB725-M3HW	930.8	484.6	190.5	254.0	3/8" NPT	3/8" NPT	64.2	867.9	515.8	127.0

Note: Not Certified dimensional drawings. Such drawings available on request.  
 Contact factory with correct model designation and serial number.  
 All dimensions are expressed in millimeters.

**BETTIS**<sup>™</sup>

www.Bettis.com

Copyright © Emerson Process Management. The information in this document is subject to change without notice.  
 Updated data sheets can be obtained from our website [www.bettis.com](http://www.bettis.com) or from your nearest Valve Automation Center.  
 USA: +1 281 727 5300 Europe: +31 74 256 1010 Asia-Pacific: +65 6501 4600

  
**EMERSON**<sup>™</sup>  
 Process Management

# Data sheet

Sheet No.: CBPM 3.06 RevC

Date: September 2011

CBB-Series

## Dimensions – (Pneumatic) mm.

### M3(HW) Override

#### Spring-Return Actuators

#### CBB XXX-SRX-M3

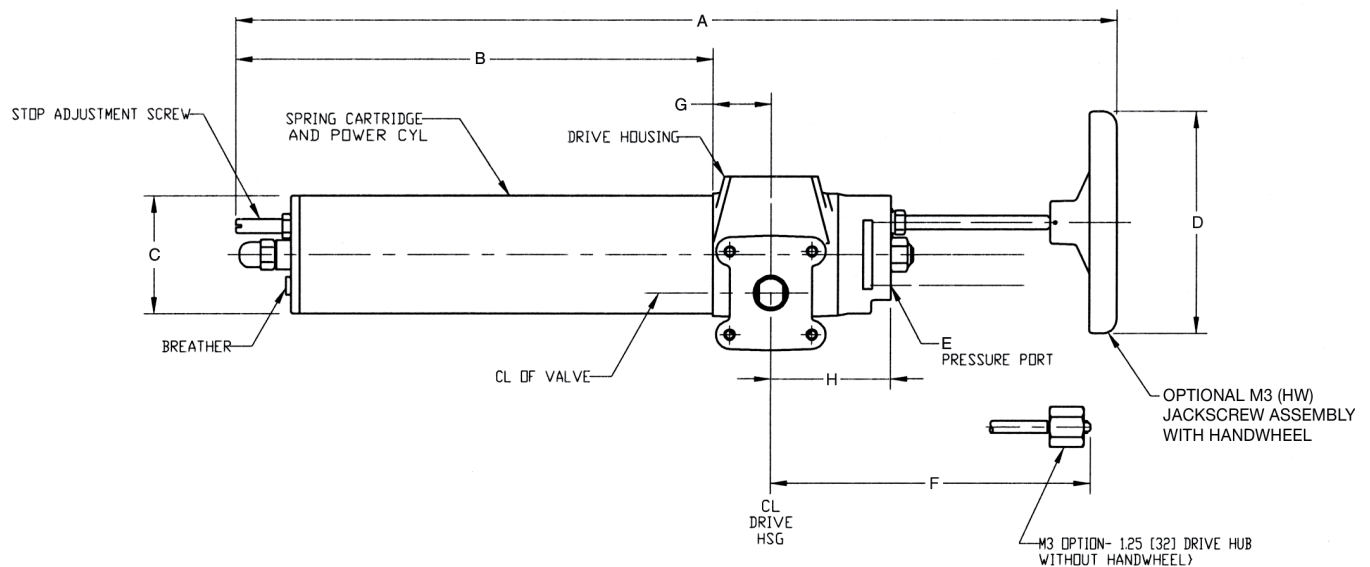

Actuator Model	A	B	C	D	E	F	G	H
CBB315-SR-M3HW	677.1	366.5	82.6	152.4	1/4" NPT	249.9	47.6	88.2
CBB415-SR-M3HW	679.1	368.6	108.0	152.4	1/4" NPT	249.9	47.6	88.2
CBB420-SR-M3HW	816.2	441.3	108.0	203.2	3/8" NPT	297.0	54.0	111.1
CBB520-SR-M3HW	816.8	442.7	136.7	203.2	3/8" NPT	297.0	53.2	111.1
CBB525-SR-M3HW	937.9	491.0	136.7	254.0	3/8" NPT	351.9	65.0	127.0
CBB725-SR-M3HW	939.2	493.1	190.5	254.0	3/8" NPT	352.1	64.2	127.0

Note: Not Certified dimensional drawings. Such drawings available on request.  
 Contact factory with correct model designation and serial number.  
 All dimensions are expressed in millimeters.

**BETTIS**<sup>™</sup>

www.Bettis.com

Copyright © Emerson Process Management. The information in this document is subject to change without notice.  
 Updated data sheets can be obtained from our website [www.bettis.com](http://www.bettis.com) or from your nearest Valve Automation Center.  
 USA: +1 281 727 5300 Europe: +31 74 256 1010 Asia-Pacific: +65 6501 4600

  
**EMERSON**<sup>™</sup>  
 Process Management

**Contact Us: Emerson Process Management, Valve Automation facilities at your nearest location:**

**NORTH & SOUTH AMERICA**

9200 Northwest Freeway  
Houston Texas 77065  
USA  
T +1 281 727 5300  
F +1 281 727 5353

2500 Park Avenue West  
Mansfield, OH 44906  
USA  
T +1 419 529 4311  
F +1 419 529 3688

9009 King Palm Drive  
Tampa, FL 33619  
USA  
T +1 813 630 2255  
F +1 813 630 9449

13840 Pike Road  
Missouri City, Texas 77489  
USA  
T +1 281 499 1561  
F +1 281 499 8445

Av. Hollingsworth,  
325, Iporanga Sorocaba,  
SP 18087-105  
Brazil  
T +55 15 3238 3788  
F +55 15 3228 3300

**MIDDLE EAST & AFRICA**

P. O. Box 17033  
Dubai  
United Arab Emirates  
T +971 4 811 8100  
F +971 4 886 5465

P. O. Box 105958  
Abu Dhabi  
United Arab Emirates  
T +971 2 697 2000  
F +971 2 555 0364

P. O. Box 3911  
Al Khobar 31952  
Saudi Arabia  
T +966 3 814 7560  
F +966 3 814 7570

P.O. Box 10305  
Jubail 31961  
Saudi Arabia  
T +966 3 340 8650  
F +966 3 340 8790

P. O. Box 32281  
Doha  
Qatar  
T +974 4 576777  
F +974 4 315448

24 Angus Crescent  
Longmeadow Business Estate East  
P.O. Box 6908; Greenstone; 1616  
Modderfontein, Extension 5  
South Africa  
T +27 11 451 3700  
F +27 11 451 3800

**EUROPE**

Asveldweg 11  
7556 BR Hengelo (O)  
The Netherlands  
T +31 74 256 1010  
F +31 74 291 0938

Siemensring 112  
47877 Willich  
Germany  
T +49 2154 499 660  
F +49 2154 499 6613

25, Rue de Villeneuve  
Silic – BP 40434  
94583 Rungis  
France  
T +33 1 49 79 73 00  
F +33 1 49 79 73 99

Via Montello 71/73  
20038 Seregno (Milan)  
Italy  
T +39 0362 2285 207  
F +39 0362 2436 55

6 Bracken Hill  
South West Industrial Estate  
Peterlee SR8 2LS  
United Kingdom  
T +44 191 518 0020  
F +44 191 518 0032

2A Szturmowa Str  
02-678 Warsaw  
Poland  
T +48 22 45 89 237  
F +48 22 45 89 231

C/ Francisco Gervás, 1  
28108 Alcobendas – Madrid  
Spain  
T +34 0913 586 000  
F +34 0913 589 145

Letnikovskaya Str. 10-2  
115114 Moscow  
Russia and FSU  
T +7 495 981 98 11  
F +7 495 981 98 10

**ASIA PACIFIC**

No. 9 Gul Road  
#01-02 Singapore 629361  
T +65 6501 4600  
F +65 6268 0028

9/F Gateway Building  
No. 10 Ya Bao Road  
Chaoyang District  
Beijing 100020  
P.R.China  
T +86 10 5821 1188  
F +86 10 5821 1100

No.15 Xing Wang Road  
Wuqing Development Area  
Tianjin 301700  
P.R.China  
T +86 22 8212 3300  
F +86 22 8212 3308

Lot 13112, Mukim Labu  
Kawasan Perindustrian Nilai  
71807 Nilai, Negeri Sembilan  
Malaysia  
T +60 6 799 2323  
F +60 6 799 9942

471 Mountain Highway  
Bayswater, Victoria 3153  
Australia  
T +61 3 9721 0200  
F +61 3 9720 0588

Delphi B Wing, 601 & 602  
6th Floor, Central Avenue  
Powai, Mumbai – 400 076  
India  
T +91 22 6662 0566  
F +91 22 6662 0500

NOF, Shinagawa Konan Bldg  
1-2-5, Higashi-shinagawa  
Shinagawa-ku, Tokyo  
140-0002 Japan  
T +81 3 5769 6873  
F +81 3 5769 6902

All rights reserved.

No part of this publication may be copied or published by means of printing, photocopying, microfilm or otherwise without prior written consent of Emerson Process Management. This restriction also applies to the corresponding drawings and diagrams.

Emerson Process Management has the right to change parts of the machine at any time without prior or direct notice to the client. The contents of this publication are subject to change without notice.

This publication is to be used for the standard version of the machine only. Thus Emerson Process Management cannot be held responsible for any damage resulting from the application of this publication to the version actually delivered to you.

For extra information as to adjustments, maintenance and repair, contact the technical department of your supplier.

This publication has been written with great care. However, Emerson Process Management cannot be held responsible, either for any errors occurring in this publication or for their consequences.

©2013 Emerson Electric Co.

**BETTIS**<sup>™</sup>

www.Bettis.com



**EMERSON**<sup>™</sup>  
Process Management