

## ICON 2000 ELECTRIC ACTUATORS

The ICON 2000 v4 series are electronically-configurable quarter and multi-turn actuators with advanced operation, control, setting and maintenance characteristics



### FEATURES

- Non-intrusive configuration
- User-friendly push-button panel for operation, setting and diagnostics
- Bluetooth™ wireless connectivity
- Watertight and explosionproof PDAs available
- Advanced maintenance data and alarm reports
- Valve condition monitoring
- Configurable 'data logger' function for maintenance and diagnostic programs in recorder or event modes
- Customized numeric and graphic displays with 8 language options
- Single enhanced terminal block
- Digital contactless torque and position sensing
- Advanced open bus communication protocols:
  - Lonworks
  - Profibus DPV0, DPV1 and redundant DPV1
  - Foundation Fieldbus
  - Modbus
  - Hart
- Suitable for use in SIL 2 applications
- Available in LP low power version with less than 1.65 A current consumption

### GENERAL APPLICATION

The ICON 2000 is available in five sizes and is designed for on/off or modulating operation of valves used in heavy industrial, chemical and petrochemical plants.

### APPROVALS

Waterproof: IP68 or NEMA 4, 4X and NEMA 6  
 Explosionproof: Ex-d IIB T4  
 Higher explosionproof classifications available  
 Suitable for use in SIL 2 applications

### TECHNICAL DATA

Power supply: 3 phase from 208 V to 690 V at 50/60 Hz  
 1 phase from 110 V to 240 V at 50/60 Hz  
 DC (Direct current) from 24 V to 110 V

Torque output: From 30 to 334,000 Nm  
 Speed range: From 12 to 173 RPM at 50/60 Hz

Ambient temperature  
 Standard range: -20°C to +85°C  
 Extended temperature ranges available

Bluetooth™ is a trademark of Bluetooth SIG, Inc., USA

# ICON 2000 ELECTRIC ACTUATORS

## COMPONENT PARTS

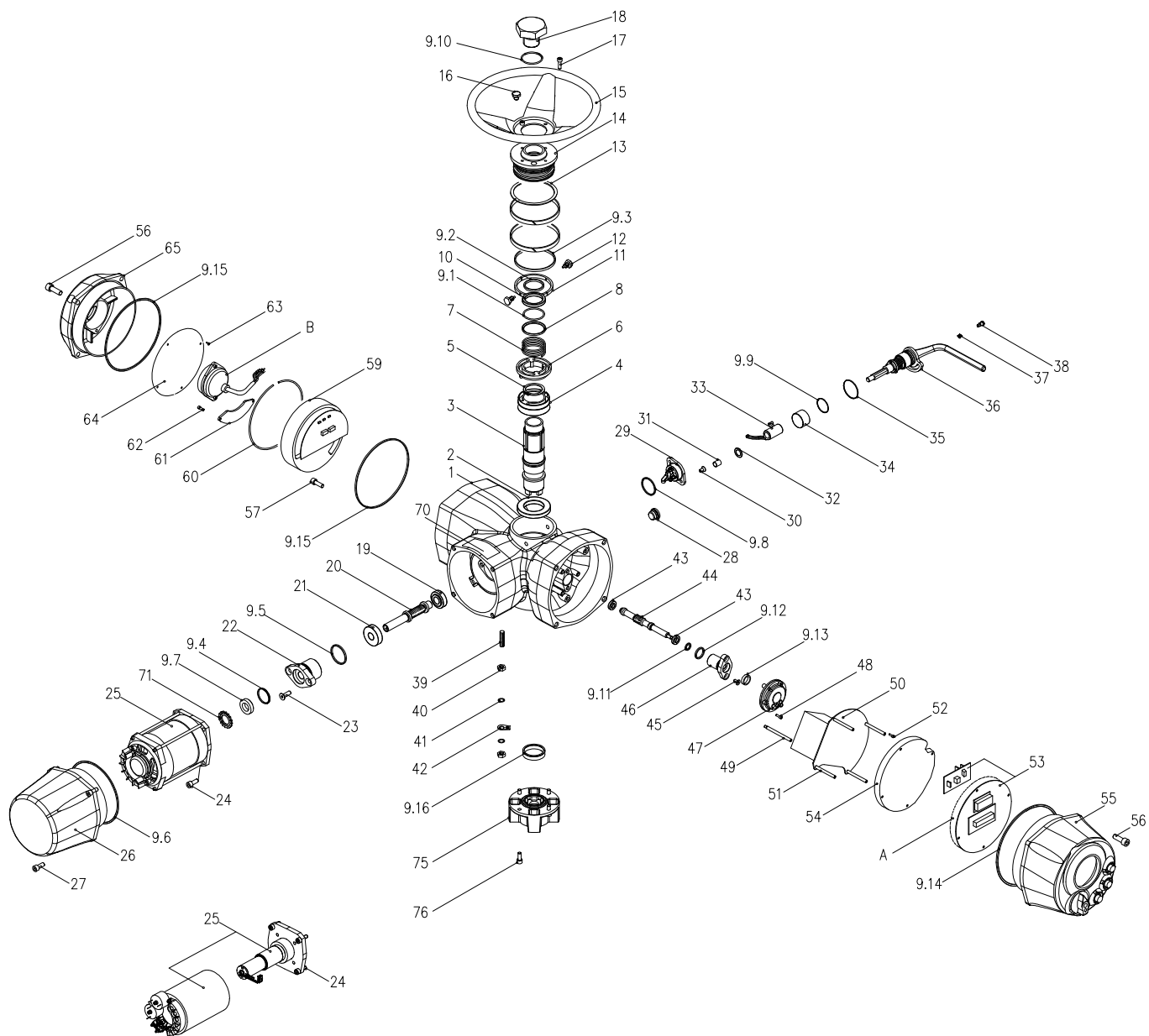

# ICON 2000 ELECTRIC ACTUATORS

## COMPONENT PARTS

### ICON 2000 COMPONENT PARTS

Item	Qty	Description	Material	Item	Qty	Description	Material
1	1	Housing	Aluminium	29	1	Finger assembly *	--
2	1	Lower bearing	Carbon steel	30	2	Screw	Stainless steel
3	1	Hollow shaft	Carbon steel	31	1	Bush	Steel-bronze-PTFE
4	1	Worm wheel	Bronze	32	1	Shoulder washer	Nylon
5	1	Circlip	Carbon steel	33	1	Fork	Carbon steel
6	1	Driver sleeve	Cast iron	34	1	Bearing bush	Carbon steel
7	1	Driver sleeve spring	Carbon steel	35	1	Lever washer	Carbon steel
8	1	Spring retaining ring	Carbon steel	36	1	Lever assembly	--
9	1	Seal kit *	--	37	1	Lever screw block	Stainless steel
9.1	1	O-ring *	FPM rubber	38	1	Screw	Carbon steel
9.2	1	Seal ring *	NBR rubber	39	1	Earth stud	Brass
9.3	1	Q-ring *	NBR rubber	40	2	Earth stud nut	Brass
9.4	1	O-ring *	NBR rubber	41	2	Washer	Carbon steel
9.5	1	O-ring *	NBR rubber	42	1	Earth stud indication plate	Stainless steel
9.6	1	O-ring *	NBR rubber	43	2	Bearing	Carbon steel
9.7	1	Seal ring *	PTFE	44	1	Position sensor shaft	Brass
9.8	1	O-ring *	NBR rubber	45	2	Screw	Stainless steel
9.9	1	O-ring *	Fluorosilcon rubber	46	1	Position sensor flange	Aluminium
9.10	1	O-ring *	NBR rubber	47	1	Position sensor assembly *	--
9.11	1	Q-ring *	NBR rubber	48	3	Screw	Stainless steel
9.12	1	O-ring *	NBR rubber	49	4	Column	Stainless steel
9.13	1	Seal ring *	PTFE	50	1	Power card *	--
9.14	1	O-ring *	NBR rubber	51	4	Column	Stainless steel
9.15	2	O-ring *	NBR rubber	52	4	Screw	Stainless steel
9.16	1	Seal ring *	NBR rubber	53	1	Processor card *	--
10	1	Upper bearing	Carbon steel	54	1	Power card cover	Nylon
11	2	Cover retaining ring	Carbon steel	55	1	Local interface assembly	--
12	2	Plug	Stainless steel	56	8	Screw	Stainless steel
13	1	Cover shoulder washer	Carbon steel	57	1	Screw	Stainless steel
14	1	Cover	Aluminium	59	1	Terminal board *	--
15	1	Handwheel	Carbon steel	60	1	Circlip	Stainless steel
16	1	Oil plug	Carbon steel	61	1	Power terminals cover	Nylon
17	4	Screw	Carbon steel	62	2	Screw	Stainless steel
18	1	Stem protection tube	Carbon steel	63	4	Screw	Stainless steel
19	1	Taper bearing	Carbon steel	64	1	Terminal board plate	Plastic
20	1	Worm shaft	Alloy steel	65	1	Terminal board cover	Aluminium
21	1	Taper bearing	Carbon steel	70	1	Data plate	Stainless steel
22	1	Worm shaft flange	Aluminium	71	1	Circlip	Stainless steel
23	2	Screw	Carbon steel	75	1	Thrust block assembly	--
24	4	Screw	Carbon steel	76	4	Screw	Stainless steel
25	1	Electric motor assembly *	--	<b>Optional</b>			
26	1	Motor cover	Aluminium	A	1	Bus interface card *	--
27	4	Screw	Stainless steel	B	1	Battery assembly	--
28	1	Oil plug	--				

\* Recommended spare parts

# ICON 2000 ELECTRIC ACTUATORS

## NON-HAZARDOUS AND HAZARDOUS AREA CERTIFICATION

### ICON 2000 STANDARD SPECIFICATIONS

#### NON-HAZARDOUS AND HAZARDOUS AREA CERTIFICATIONS

##### Enclosure / weatherproof standards (IEC / NEMA)

Standards	Enclosure marking	Version	Temperature range		
			3-ph		
			Up to 60 st/hr	> 60 st/hr	1-ph & DC
IEC EN 60529	IP66 / IP68	Standard temperature	-20°C/+85°C	-20°C/+65°C	-20°C/+65°C
		Low temperature	-40°C/+85°C	-40°C/+65°C	-40°C/+65°C
		Extra low temperature	-60°C/+65°C	-60°C/+65°C	-60°C/+65°C
NEMA 250	NEMA 4, 4X, 6	Standard temperature	-20°C/+85°C	-20°C/+65°C	-20°C/+65°C
		Low temperature	-40°C/+85°C	-40°C/+65°C	-40°C/+65°C
		Extra low temperature	-55°C/+65°C	-55°C/+65°C	-55°C/+65°C

##### European standards hazardous areas (ATEX)

Standards	Enclosure marking		Version	Temperature range		
	Gas	Dust		3-ph		
	Up to 60 st/hr	> 60 st/hr		1-ph & DC		
ATEX (60079)	Ex d IIB T4 Gb §	Ex tb IIIC T135°C Db	Standard temperature	-20°C/+65°C [TM]	-20°C/+65°C	-20°C/+65°C
				-20°C/+85°C	-20°C/+65°C	-20°C/+65°C
ATEX (60079)	Ex d IIB T4 Gb §	Ex tb IIIC T135°C Db	Low temperature	-40°C/+65°C [TM]	-40°C/+65°C	-40°C/+65°C
			ICON 010, 020 <sup>[1]</sup>	-40°C/+85°C	-40°C/+65°C	-40°C/+65°C
ATEX (60079)	Ex d IIB T4 Gb §	Ex tb IIIC T135°C Db	Extra Low temperature	-60°C/+65°C [TM]	-60°C/+65°C	-60°C/+65°C
			ICON 010, 020 <sup>[1]</sup>	-60°C/+85°C	-60°C/+65°C	-60°C/+65°C
ATEX (60079)	Ex d IIB T4 Gb §	Ex tb IIIC T135°C Db	Low temperature	-40°C/+65°C [TM]	-40°C/+65°C	-40°C/+65°C
			ICON 030, 040, 050 <sup>[1]</sup>	-40°C/+85°C	-40°C/+65°C	-40°C/+65°C
ATEX (60079)	Ex d IIB T4 Gb §	Ex tb IIIC T135°C Db	Extra Low temperature	-55°C/+65°C [TM]	-55°C/+65°C	-55°C/+65°C
			ICON 030, 040, 050 <sup>[1]</sup>	-55°C/+85°C	-55°C/+65°C	-55°C/+65°C
ATEX (60079)	c Ex d e IIB T4 Gb §	c Ex tb IIIC T135°C Db	Standard temperature	-25°C/+60°C	-25°C/+60°C	-25°C/+60°C
ATEX (60079)	c Ex d IIC T4 Gb <sup>[2]</sup> §	c Ex tb IIIC T135°C Db <sup>[2]</sup>	Standard temperature	-20°C/+85°C	-20°C/+85°C	-20°C/+85°C
ATEX (60079)	c Ex d IIC T4 Gb <sup>[2]</sup> §	c Ex tb IIIC T135°C Db <sup>[2]</sup>	Low temperature	-40°C/+85°C	-40°C/+85°C	-40°C/+85°C
ATEX (60079)	c Ex d IIC T4 Gb <sup>[2]</sup> §	c Ex tb IIIC T135°C Db <sup>[2]</sup>	Extra Low temperature	-60°C/+85°C	-60°C/+85°C	-60°C/+85°C
			ICON 010, 020 <sup>[2]</sup>			
ATEX (60079)	c Ex d e IIC T4 Gb <sup>[3]</sup> §	c Ex tb IIIC T135°C Db <sup>[3]</sup>	Standard temperature	-25°C/+60°C	-25°C/+60°C	-25°C/+60°C
ATEX (60079)	c Ex d e IIB+H2 T4 Gb <sup>[4]</sup> §	c Ex tb IIIC T135°C Db <sup>[4]</sup>	Standard temperature	-25°C/+60°C	-25°C/+60°C	-25°C/+60°C

##### North American standards hazardous areas (NEC / CSA / FM)

Standards	Enclosure marking		Version	Temperature range		
	Gas	Dust		3-ph		
	15' duty rating	30' duty rating		1-ph & DC		
NEC 500 CSA	Class 1, Group C, D	Class II, Groups E, F and G; Class III	Standard temperature	Up to 60 st/hr -40°C/+70°C	> 60 st/hr -40°C/+70°C	-40°C/+70°C
NEC 500 FM	Class 1, Division 1, Groups C and D	Class II, Groups E, F and G; Class III	Standard temperature	-25°C/+70°C	-25°C/+60°C	-25°C/+60°C

#### NOTES

§ With battery: add ia

1. With extension lowest temp limited to -20°C
2. Applicable to models ICON 2000 010, 020
3. Applicable to models ICON 2000 010, 020, 030
4. Applicable to models ICON 2000 040, 050

# ICON 2000 ELECTRIC ACTUATORS

## NON-HAZARDOUS AND HAZARDOUS AREA CERTIFICATION

### International standards hazardous areas (IECEX)

Standards	Enclosure marking			Temperature range		
	Gas	Dust	Version	3-ph		
				Up to 60 st/hr	> 60 st/hr	1-ph & DC
IECEX	Ex d IIB T4 Gb §	Ex tb IIIC T135°C Db	Standard temperature	-20°C/+85°C	-20°C/+65°C	-20°C/+65°C
IECEX	Ex d IIB T4 Gb §	Ex tb IIIC T135°C Db	Low temperature ICON 010, 020 <sup>[1]</sup>	-40°C/+85°C	-40°C/+65°C	-40°C/+65°C
IECEX	Ex d IIB T4 Gb §	Ex tb IIIC T135°C Db	Extra Low temperature ICON 010, 020 <sup>[1]</sup>	-60°C/+85°C	-60°C/+65°C	-60°C/+65°C
IECEX	Ex d IIB T4 Gb §	Ex tb IIIC T135°C Db	Low temperature ICON 030, 040, 050 <sup>[1]</sup>	-40°C/+85°C	-40°C/+65°C	-40°C/+65°C
IECEX	Ex d IIB T4 Gb §	Ex tb IIIC T135°C Db	Extra Low temperature ICON 030, 040, 050 <sup>[1]</sup>	-55°C/+85°C	-55°C/+65°C	-55°C/+65°C

### INMETRO Brazilian standards hazardous area

Standards	Enclosure marking			Temperature range		
	Gas	Dust	Version	3-ph		
				Up to 60 st/hr	> 60 st/hr	1-ph & DC
INMETRO	Ex d IIB T4 Gb §	Ex tb IIIC T135°C Db	Standard temperature	-20°C/+65°C [TM] -20°C/+85°C	-20°C/+65°C	-20°C/+65°C
INMETRO	Ex d IIB T4 Gb §	Ex tb IIIC T135°C Db	Low temperature ICON 010, 020 <sup>[1]</sup>	-40°C/+65°C [TM] -40°C/+85°C	-40°C/+65°C	-40°C/+65°C
INMETRO	Ex d IIB T4 Gb §	Ex tb IIIC T135°C Db	Extra Low temperature ICON 010, 020 <sup>[1]</sup>	-60°C/+65°C [TM] -60°C/+85°C	-60°C/+65°C	-60°C/+65°C
INMETRO	Ex d IIB T4 Gb §	Ex tb IIIC T135°C Db	Low temperature ICON 030, 040, 050 <sup>[1]</sup>	-40°C/+65°C [TM] -40°C/+85°C	-40°C/+65°C	-40°C/+65°C
INMETRO	Ex d IIB T4 Gb §	Ex tb IIIC T135°C Db	Extra Low temperature ICON 030, 040, 050 <sup>[1]</sup>	-55°C/+65°C [TM] -55°C/+85°C	-55°C/+65°C	-55°C/+65°C

### EAC CoC Russian standards hazardous area

Standards	Enclosure marking			Temperature range		
	Gas	Dust	Version	3-ph		
				Up to 60 st/hr	> 60 st/hr	1-ph & DC
EAC CoC	Ex d IIB T4 Gb §	Ex tb IIIC T135°C Db	Standard temperature	-20°C/+65°C [TM] -20°C/+85°C	-20°C/+65°C	-20°C/+65°C
EAC CoC	Ex d IIB T4 Gb §	Ex tb IIIC T135°C Db	Low temperature ICON 010, 020 <sup>[1]</sup>	-40°C/+65°C [TM] -40°C/+85°C	-40°C/+65°C	-40°C/+65°C
EAC CoC	Ex d IIB T4 Gb §	Ex tb IIIC T135°C Db	Extra Low temperature ICON 010, 020 <sup>[1]</sup>	-60°C/+65°C [TM] -60°C/+85°C	-60°C/+65°C	-60°C/+65°C
EAC CoC	Ex d IIB T4 Gb §	Ex tb IIIC T135°C Db	Low temperature ICON 030, 040, 050 <sup>[1]</sup>	-40°C/+65°C [TM] -40°C/+85°C	-40°C/+65°C	-40°C/+65°C
EAC CoC	Ex d IIB T4 Gb §	Ex tb IIIC T135°C Db	Extra Low temperature ICON 030, 040, 050 <sup>[1]</sup>	-55°C/+65°C [TM] -55°C/+85°C	-55°C/+65°C	-55°C/+65°C

### KOSHA Korean standards hazardous area

Standards	Enclosure marking			Temperature range		
	Gas	Dust	Version	3-ph		
				Up to 60 st/hr	> 60 st/hr	1-ph & DC
KOSHA	Ex d IIB T4 Gb §	Ex tb IIIC T135°C Db	Standard temperature	-20°C/+65°C [TM] -20°C/+85°C	-20°C/+65°C	-20°C/+65°C
KOSHA	Ex d IIB T4 Gb §	Ex tb IIIC T135°C Db	Low temperature ICON 010, 020 <sup>[1]</sup>	-40°C/+65°C [TM] -40°C/+85°C	-40°C/+65°C	-40°C/+65°C
KOSHA	Ex d IIB T4 Gb §	Ex tb IIIC T135°C Db	Extra Low temperature ICON 010, 020 <sup>[1]</sup>	-60°C/+65°C [TM] -60°C/+85°C	-60°C/+65°C	-60°C/+65°C
KOSHA	Ex d IIB T4 Gb §	Ex tb IIIC T135°C Db	Low temperature ICON 030, 040, 050 <sup>[1]</sup>	-40°C/+65°C [TM] -40°C/+85°C	-40°C/+65°C	-40°C/+65°C
KOSHA	Ex d IIB T4 Gb §	Ex tb IIIC T135°C Db	Extra Low temperature ICON 030, 040, 050 <sup>[1]</sup>	-55°C/+65°C [TM] -55°C/+85°C	-55°C/+65°C	-55°C/+65°C

### NOTES

§ With battery: add ia

1. With extension lowest temp limited to -20°C

# ICON 2000 ELECTRIC ACTUATORS

## BASE VERSION FEATURES

---

### BASE VERSION FEATURES

---

#### REMOTE CONTROLS

4 wires (OP, CL, Stop, C/latched)  
3 wires (OP, CL, C/push-to-run or latched with instant reverse)  
2 wires (NO contact to open or reverse)

#### Control voltage

24 V DC, internal supply  
20 to 125 V DC, external supply

#### REMOTE OUTPUT CONTACTS

##### Status

Open limit  
Closed limit  
Position  $\geq$ xx %  
Position  $\leq$ xx %  
Closing  
Opening  
Motor running blinker  
Mid-travel position  
Local selected  
Remote selected  
Local stop active  
ESD signal on  
Manual operation

##### Alarms

Motor over-temperature  
Over-torque over torque in OP  
Over-torque in CL  
Valve jammed in OP  
Valve jammed in CL  
Valve jammed  
Warnings  
Low lithium battery (if present)  
Mid-travel alarm in CL/OP  
Mains-only AS8

#### EMERGENCY SHUTDOWN (ESD)

Selector in LOCAL  
Selector in OFF  
Motor temperature alarm  
Local STOP pushbutton  
Torque alarm  
2 speed timer  
Stay put  
Move to open position  
Move to close position  
Move to pre-set position

#### MONITOR RELAY

Loss of power  
Loss of one phase  
Electrical contactor failure  
Loss of one phase  
Local stop activated  
Local selector switch in LOCAL/OFF  
Internal temperature alarm  
Position sensor  
Hardware error  
Motor temperature alarm  
Torque alarm  
Jammed valve  
Mid-travel alarm  
Speed sensor configuration error  
Manual operation  
ESD signal  
Low battery

#### INTELLIGENT PROTECTION

Automatic phase correction  
Phase failure correction  
Motor thermostat  
Jammed valve protection  
Anti-hammer protection  
Instantaneous reversal protection

#### Warnings

Contact failure  
Maximum torque alarm  
Torque alarm by-pass  
High/low electronic temperature  
Opto-coupled remote controls

#### VALVE MONITORING

---

##### TORQUE PROFILES

Breakout reference torque in opening  
Peak running reference torque in opening  
Ending reference torque in opening  
Breakout torque in opening  
Peak running torque in opening  
Ending torque in opening  
Breakout reference torque in closing  
Peak running reference torque in closing  
Ending reference torque in closing  
Breakout torque in closing  
Peak running torque in closing  
Ending torque in closing  
Date of the last 'set torque reference'  
Date of last torque profile in opening  
Date of last torque profile in closing

#### OPERATIONS

Opening time of the last stroke  
Closing time of last stroke  
Total contactor operations  
Motor run time  
Time out without electrical power  
Utilization rate  
Torque alarm number  
Motor temperature alarm number  
Min and max temperature of motor and electronics  
Recent contactor operations  
Recent motor run time  
Recent time without electrical power  
Recent utilization rate  
Recent torque alarm number  
Recent motor temperature alarm number  
Recent min and max temperature of motor and electronic

#### ALARMS

Last 64 alarms and date  
Last 64 warnings and date

#### MAINTENANCE DATA

Last maintenance date  
Next maintenance date  
Date of the last 'clear recent data log'  
Start-up date

#### NAME PLATE

Serial number  
Actuator size  
Nominal torque  
Actuator speed  
Power supply  
Motor rating  
Motor duty  
Motor poles  
Motor type  
Motor current  
Test date  
Wiring diagram  
Enclosure  
Certificate  
Lubricant  
HW version  
SW version

#### VALVE DATA

Valve tag name  
Valve serial number  
Valve manufacturer  
Break to open torque  
Max stem thrust  
Valve coupling type

# ICON 2000 ELECTRIC ACTUATORS

## PERFORMANCE AND MOTOR DATA

ICON 2000 actuators can be supplied for single phase, three phase and DC power supplies. Performance and motor data is provided for the models indicated in the table below.

### PERFORMANCE AND MOTOR DATA

Voltages	Power supply			Model				
	Single phase	Three phase	DC	ICON 010	ICON 020	ICON 030	ICON 040	ICON 050
24 V			√	√				
48 V			√	√				
110 V			√	√	√			
115 V	*			√	√			
120 V	√		√	√	√			
220 V	*	*		√	√	√	Δ	Δ
230 V	√	√		√	√	√	Δ	Δ
240 V	√	√		√	√	√	Δ	Δ
380 V		√		√	√	√	√	√
400 V		*		√	√	√	√	√
415 V		√		√	√	√	√	√
440 V		√		√	√	√	√	√
460 V		√		√	√	√	√	√
500 V		*		√	√	√	√	√
660 V		*		√	√	√	√	√
690 V		*		√	√	√	√	√

√ Available in the catalog

\* Available on request

Δ Available only with three phases

For all performance and motor data the following notes apply:

#### Voltages

The tolerances on all voltage values shown are +/- 10% (continuous) +10% -15% (intermittent)

#### Nominal duties

Nominal duties are -5% / +5% according to (IEC 60034-1)

#### Nominal output power

Nominal output power (kW) is according to (IEC 60034-1)

#### Motors

All performance figures are based on Motor class H

#### Published values

The tolerances on published values are all according to (IEC 60034-1)

# ICON 2000 ELECTRIC ACTUATORS

## PERFORMANCE SINGLE PHASE SUPPLY 120 V / 60 Hz

### ON/OFF S2-15' OR INCHING SERVICE S4-25%, 60 STARTS/hr

Model	Nom. torque (100%) Nm	Min. torque (40%) Nm	Actuator		Motor power (kW)	Motor <sup>[3]</sup>	Motor <sup>[4]</sup>	Locked <sup>[5]</sup>	Eff. % nom	Power factor	Absorbed <sup>[6]</sup> power (Watt)
			RPM	R		nominal current (Inom)	max current (Imax)	rotor current (Icc)			
ICON-010/30-SR1	30	12	8 - 17	40:1	0.127	3.00	5.50	9.30	38.8	0.91	328
ICON-010/30-SR2	30	12	18 - 62	20:1	0.343	3.80	8.70	13.20	79.2	0.95	433
ICON-010/30-SR3	30	12	63 - 94	20:1	0.440	7.00	9.80	22.00	55.1	0.95	798
ICON-010/90-SR1	90	36	6 - 23	40:1	0.221	5.50	10.70	23.00	37.2	0.90	594
ICON-010/90-SR2	90	36	24 - 40	20:1	0.343	3.80	8.70	13.20	79.2	0.95	433
ICON-020/180-SR1	180	72	10 - 20	40:1	0.631	12.80	16.00	25.00	45.6	0.90	1382

#### NOTES

- Asynchronous motors with DELTA connections
- The last digits in the model number represent the range of adjustable output speed (RPM) shown on the table
- Inom – Actuator nominal current (at 40% set output torque) according to ISO 12590
- Imax – Actuator current at max torque (100% set output torque) according to ISO 12590
- Icc – Actuator locked rotor current (current measured with motor energized and output drive locked) according to ISO 12590
- Absorbed power at nominal conditions (Watt)

### MODULATING SERVICE S4-50%, 1200 STARTS/hr

Model	Nom. torque (100%) Nm	Min. torque (40%) Nm	Actuator		Motor power (kW)	Motor <sup>[3]</sup>	Motor <sup>[4]</sup>	Locked <sup>[5]</sup>	Eff. % nom	Power factor	Absorbed <sup>[6]</sup> power (Watt)
			RPM	R		nominal current (Inom)	max current (Imax)	rotor current (Icc)			
ICON-010R/30-SR1	30	12	8 - 17	40:1	0.127	3.00	5.50	9.30	38.8	0.91	328
ICON-010R/30-SR2	30	12	24 - 72	20:1	0.343	3.80	8.70	13.20	79.2	0.95	433
ICON-010R/30-SR3	30	12	73 - 90	20:1	0.440	7.00	9.80	22.00	55.1	0.96	798
ICON-010R/90-SR1	90	36	6 - 23	40:1	0.221	5.50	10.70	23.00	37.2	0.90	594
ICON-010R/90-SR2	90	36	24 - 40	20:1	0.343	3.80	8.70	13.20	79.2	0.95	433
ICON-020R/180-SR1	180	72	8 - 20	40:1	0.631	12.80	16.00	25.00	45.6	0.90	1382

#### NOTES

- Asynchronous motors with DELTA connections
- The last digits in the model number represent the range of adjustable output speed (RPM) shown on the table
- Inom – Actuator nominal current (at 40% set output torque) according to ISO 12590
- Imax – Actuator current at max torque (100% set output torque) according to ISO 12590
- Icc – Actuator locked rotor current (current measured with motor energized and output drive locked) according to ISO 12590
- Absorbed power at nominal conditions (Watt)



# ICON 2000 ELECTRIC ACTUATORS

## PERFORMANCE SINGLE PHASE SUPPLY 230 V / 50 Hz

### ON/OFF S2-15' OR INCHING SERVICE S4-25%, 60 STARTS/hr

Model	Nom. torque (100%) Nm	Min. torque (40%) Nm	Actuator		Motor power (kW)	Motor <sup>[3]</sup>	Motor <sup>[4]</sup>	Locked <sup>[5]</sup>	Eff. % nom	Power factor	Absorbed <sup>[6]</sup> power (Watt)
			RPM	R		nominal current (Inom)	max current (Imax)	rotor current (Icc)			
ICON-010/30-SR1	30	12	8 - 17	40:1	0.106	1.10	1.80	4.00	46.0	0.91	230
ICON-010/30-SR2	30	12	24 - 72	20:1	0.367	2.70	5.30	11.00	62.2	0.95	590
ICON-010/30-SR3	30	12	73 - 172	20:1	0.735	6.80	9.00	20.00	49.0	0.96	1501
ICON-010/90-SR1	90	36	6 - 23	40:1	0.184	3.20	5.50	11.50	27.8	0.90	662
ICON-010/90-SR2	90	36	24 - 95	20:1	0.789	7.70	12.00	27.00	47.4	0.94	1665
ICON-010/90-SR3	90	36	96 - 120	20:1	1.470	10.50	15.00	40.00	66.9	0.91	2198
ICON-020/180-SR1	180	72	12 - 36	40:1	0.789	6.50	10.50	18.00	56.7	0.93	1390
ICON-020/180-SR2	180	72	48 - 60	20:1	0.789	9.50	16.00	40.00	39.2	0.92	2010
ICON-030/360-SR1	360	144	10 - 30	40:1	1.123	12.00	16.50	25.00	42.8	0.95	2622

#### NOTES

- Asynchronous motors with DELTA connections
- The last digits in the model number represent the range of adjustable output speed (RPM) shown on the table
- Inom – Actuator nominal current (at 40% set output torque) according to ISO 12590
- Imax – Actuator current at max torque (100% set output torque) according to ISO 12590
- Icc – Actuator locked rotor current (current measured with motor energized and output drive locked) according to ISO 12590
- Absorbed power at nominal conditions (Watt)

### MODULATING SERVICE S4-50%, STARTS/hr

Model	Nom. torque (100%) Nm	Min. torque (40%) Nm	Actuator		Motor power (kW)	Motor <sup>[3]</sup>	Motor <sup>[4]</sup>	Locked <sup>[5]</sup>	Eff. % nom	Power factor	Absorbed <sup>[6]</sup> power (Watt)
			RPM	R		nominal current (Inom)	max current (Imax)	rotor current (Icc)			
ICON-010R/30-SR1	30	12	8 - 17	40:1	0.106	1.10	1.80	4.00	46.0	0.91	230
ICON-010R/30-SR2	30	12	24 - 72	20:1	0.367	2.70	5.30	11.00	62.2	0.95	590
ICON-010R/30-SR3	30	12	73 - 95	20:1	0.735	6.80	9.00	20.00	49.0	0.96	1501
ICON-010R/90-SR1	90	36	6 - 23	40:1	0.184	3.20	5.50	11.50	27.8	0.90	662
ICON-010R/90-SR2	90	36	24 - 95	20:1	0.500	3.20	6.90	17.50	72.3	0.94	692
ICON-020R/180-SR1	180	72	12 - 36	40:1	0.789	6.50	10.50	18.00	56.7	0.93	1390
ICON-020R/180-SR2	180	72	48 - 60	20:1	0.789	9.50	16.00	40.00	39.2	0.92	2010
ICON-030R/360-SR1	360	144	10 - 30	40:1	1.123	12.00	16.50	25.00	42.8	0.95	2622

#### NOTES

- Asynchronous motors with DELTA connections
- The last digits in the model number represent the range of adjustable output speed (RPM) shown on the table
- Inom – Actuator nominal current (at 40% set output torque) according to ISO 12590
- Imax – Actuator current at max torque (100% set output torque) according to ISO 12590
- Icc – Actuator locked rotor current (current measured with motor energized and output drive locked) according to ISO 12590
- Absorbed power at nominal conditions (Watt)

# ICON 2000 ELECTRIC ACTUATORS

## PERFORMANCE SINGLE PHASE SUPPLY 240 V / 60 Hz

### ON/OFF S2-15' OR INCHING SERVICE S4-25%, 60 STARTS/hr

Model	Nom. torque (100%) Nm	Min. torque (40%) Nm	Actuator RPM	R	Motor power (kW)	Motor <sup>[3]</sup>	Motor <sup>[4]</sup>	Locked <sup>[5]</sup>	Eff. % nom	Power factor	Absorbed <sup>[6]</sup> power (Watt)
						nominal current (Inom)	max current (Imax)	rotor current (Icc)			
ICON-010/30-SR1	30	12	8 - 17	40:1	0.127	1.27	2.07	4.60	46.0	0.91	276
ICON-010/30-SR2	30	12	24 - 72	20:1	0.440	3.11	6.10	12.65	62.2	0.95	708
ICON-010/30-SR3	30	12	73 - 172	20:1	0.882	7.82	10.35	23.00	49.0	0.96	1802
ICON-010/90-SR1	90	36	6 - 23	40:1	0.221	3.68	6.33	13.23	27.8	0.90	795
ICON-010/90-SR2	90	36	24 - 95	20:1	0.947	8.86	13.80	31.05	47.4	0.94	1998
ICON-010/90-SR3	90	36	96 - 120	20:1	1.764	9.78	17.25	46.00	82.6	0.91	2135
ICON-020/180-SR1	180	72	12 - 36	40:1	0.947	7.48	12.08	20.70	56.8	0.93	1668
ICON-020/180-SR2	180	72	48 - 60	20:1	0.947	11.50	18.40	46.00	37.3	0.92	2539
ICON-030/360-SR1	360	144	10 - 30	40:1	1.348	13.80	18.98	28.75	42.8	0.95	3146

#### NOTES

1. Asynchronous motors with DELTA connections
2. The last digits in the model number represent the range of adjustable output speed (RPM) shown on the table
3. Inom – Actuator nominal current (at 40% set output torque) according to ISO 12590
4. Imax – Actuator current at max torque (100% set output torque) according to ISO 12590
5. Icc – Actuator locked rotor current (current measured with motor energized and output drive locked) according to ISO 12590
6. Absorbed power at nominal conditions (Watt)

### MODULATING SERVICE S4-50%, 1200 STARTS/hr

Model	Nom. torque (100%) Nm	Min. torque (40%) Nm	Actuator RPM	R	Motor power (kW)	Motor <sup>[3]</sup>	Motor <sup>[4]</sup>	Locked <sup>[5]</sup>	Eff. % nom	Power factor	Absorbed <sup>[6]</sup> power (Watt)
						nominal current (Inom)	max current (Imax)	rotor current (Icc)			
ICON-010R/30-SR1	30	12	8 - 17	40:1	0.127	1.27	2.07	4.60	46.0	0.91	276
ICON-010R/30-SR2	30	12	24 - 72	20:1	0.440	3.11	6.10	12.65	62.2	0.95	708
ICON-010R/30-SR3	30	12	73 - 95	20:1	0.882	7.82	10.35	23.00	49.0	0.96	1802
ICON-010R/90-SR1	90	36	6 - 23	40:1	0.221	3.68	6.33	13.23	27.8	0.90	795
ICON-010R/90-SR2	90	36	24 - 95	20:1	0.600	3.72	8.02	20.25	73.0	0.92	821
ICON-020R/180-SR1	180	72	12 - 36	40:1	0.947	7.48	12.08	20.70	56.8	0.93	1668
ICON-020R/180-SR2	180	72	48 - 60	20:1	0.947	11.50	18.40	46.00	37.3	0.92	2539
ICON-030R/360-SR1	360	144	10 - 30	40:1	1.348	13.80	18.98	28.75	42.8	0.95	3146

#### NOTES

1. Asynchronous motors with DELTA connections
2. The last digits in the model number represent the range of adjustable output speed (RPM) shown on the table
3. Inom – Actuator nominal current (at 40% set output torque) according to ISO 12590
4. Imax – Actuator current at max torque (100% set output torque) according to ISO 12590
5. Icc – Actuator locked rotor current (current measured with motor energized and output drive locked) according to ISO 12590
6. Absorbed power at nominal conditions (Watt)

# ICON 2000 ELECTRIC ACTUATORS

PERFORMANCE THREE PHASE SUPPLY 380 V / 50 Hz - 60 STARTS/hr

## ON/OFF S2-15' OR INCHING SERVICE S4-25%, 60 STARTS/hr

Model	Nom. torque (100%) Nm	Min. torque (40%) Nm	Actuator		Motor power (kW)	Motor RPM	Motor <sup>[1]</sup>	Motor <sup>[2]</sup>	Locked <sup>[3]</sup>	Eff. % nom	Power factor	Absorbed <sup>[4]</sup> power (Watt)
			RPM	R			nominal current (Inom)	max current (Imax)	rotor current (Icc)			
ICON-010/30-12	30	12	12	40:1	0.030	488	0.44	0.51	0.68	22.4	0.46	134
ICON-010/30-18	30	12	18	40:1	0.046	732	0.46	0.58	0.89	35.9	0.42	128
ICON-010/30-24	30	12	24	20:1	0.071	488	1.26	1.37	1.79	19.9	0.43	357
ICON-010/30-36	30	12	36	20:1	0.106	732	1.16	1.37	2.32	32.3	0.43	328
ICON-010/30-48	30	12	48	20:1	0.142	975	0.99	1.16	2.42	46.4	0.47	306
ICON-010/30-72	30	12	72	20:1	0.213	1463	0.86	1.26	3.47	67.0	0.56	318
ICON-010/30-144	30	12	144	20:1	0.426	2926	1.32	2.21	6.32	69.3	0.71	615
ICON-010/90-12	90	36	12	40:1	0.071	488	1.26	1.37	1.79	19.9	0.43	357
ICON-010/90-18	90	36	18	40:1	0.106	732	1.16	1.37	2.32	32.3	0.43	328
ICON-010/90-24	90	36	24	20:1	0.122	488	2.11	2.21	3.16	19.1	0.46	637
ICON-010/90-36	90	36	36	20:1	0.184	732	1.68	2.00	3.89	40.5	0.41	454
ICON-010/90-48	90	36	48	20:1	0.286	975	1.53	1.89	4.84	61.9	0.46	462
ICON-010/90-72	90	36	72	20:1	0.367	1463	1.79	2.63	7.89	56.7	0.55	648
ICON-010/90-144	90	36	144	20:1	0.735	2926	2.32	4.63	12.63	72.0	0.67	1021
ICON-020/180-12	180	72	12	40:1	0.122	488	2.11	2.21	3.16	19.1	0.46	637
ICON-020/180-18	180	72	18	40:1	0.184	732	1.68	2.00	3.89	40.5	0.41	454
ICON-020/180-24	180	72	24	40:1	0.286	975	1.53	1.89	4.84	61.9	0.46	462
ICON-020/180-36	180	72	36	40:1	0.367	1463	1.79	2.63	7.89	56.7	0.55	648
ICON-020/180-48	180	72	48	20:1	0.526	975	3.26	4.11	10.32	57.0	0.43	924
ICON-020/180-72	180	72	72	20:1	0.789	1463	2.84	4.53	12.63	69.1	0.61	1141
ICON-020/180-144	180	72	144	20:1	1.470	2926	4.21	7.89	24.21	79.2	0.67	1857
ICON-030/360-12	360	144	12	80:1	0.526	975	3.26	4.11	10.32	57.0	0.43	924
ICON-030/360-18	360	144	18	40:1	0.500	730	3.05	5.05	10.00	64.6	0.39	775
ICON-030/360-24	360	144	24	40:1	0.526	975	3.26	4.11	10.32	57.0	0.43	924
ICON-030/360-36	360	144	36	40:1	0.789	1463	2.84	4.53	12.63	69.1	0.61	1141
ICON-030/360-48	360	144	48	20:1	1.123	975	5.68	12.74	20.53	69.8	0.43	1609
ICON-030/360-72	360	144	72	40:1	1.470	2926	4.21	7.89	24.21	79.2	0.67	1857
ICON-030/360-144	360	144	144	20:1	3.368	2926	9.26	18.53	54.74	81.2	0.68	4146
ICON-040/720-12	720	288	12	80:1	1.123	975	5.68	12.74	20.53	69.8	0.43	1609
ICON-040/720-18	720	288	18	40:1	0.840	730	4.95	8.42	15.79	66.2	0.39	1268
ICON-040/720-24	720	288	24	40:1	1.123	975	5.68	12.74	20.53	69.8	0.43	1609
ICON-040/720-36	720	288	36	40:1	1.684	1463	4.53	6.84	31.58	84.4	0.67	1996
ICON-040/720-48	720	288	48	20:1	1.939	975	8.00	13.68	26.32	75.2	0.49	2580
ICON-040/720-72	720	288	72	40:1	3.368	2926	9.26	18.53	54.74	81.2	0.68	4146
ICON-040/720-144	720	288	144	20:1	5.818	2926	14.11	29.47	87.37	85.8	0.73	6777
ICON-050/1440-12	1440	576	12	80:1	1.939	975	8.00	13.68	26.32	75.2	0.49	2580
ICON-050/1440-18	1440	576	18	80:1	1.684	1463	4.53	6.84	31.58	84.4	0.67	1996
ICON-050/1440-24	1440	576	24	40:1	1.939	975	8.00	13.68	26.32	75.2	0.49	2580
ICON-050/1440-36	1440	576	36	40:1	2.885	1449	9.74	15.79	73.68	80.4	0.56	3589
ICON-050/1440-48	1440	576	48	20:1	3.879	975	11.58	20.00	84.21	83.4	0.61	4649
ICON-050/1440-72	1440	576	72	40:1	5.818	2926	14.11	29.47	87.37	85.8	0.73	6777
ICON-050/1440-144	1440	576	144	20:1	11.636	2926	28.95	60.00	136.84	86.0	0.71	13527

### NOTES

1. Inom – Actuator nominal current (at 40% set output torque) according to ISO 12590
2. Imax – Actuator current at max torque (100% set output torque) according to ISO 12590
3. Icc – Actuator locked rotor current (current measured with motor energized and output drive locked) according to ISO 12590
4. Absorbed power at nominal conditions (Watt)

# ICON 2000 ELECTRIC ACTUATORS

PERFORMANCE THREE PHASE SUPPLY 380 V / 50 Hz - 600 TO 1200 STARTS/hr

## ON/OFF S2-30' OR INCHING SERVICE S4-25%, 600 STARTS/hr; MODULATING SERVICE S4-50%, 1200 STARTS/hr

Model	Nom. torque (100%) Nm	Min. torque (40%) Nm	Actuator		Motor power (kW)	Motor RPM	Motor <sup>[1]</sup>	Motor <sup>[2]</sup>	Locked <sup>[3]</sup>	Eff. % nom	Power factor	Absorbed <sup>[4]</sup> power (Watt)
			RPM	R			nominal current (Inom)	max current (Imax)	rotor current (Icc)			
ICON-010R/30-12	30	12	12	40:1	0.030	488	0.44	0.51	0.68	22.4	0.46	134
ICON-010R/30-18	30	12	18	40:1	0.046	732	0.46	0.58	0.89	35.9	0.42	128
ICON-010R/30-24	30	12	24	20:1	0.071	488	1.26	1.37	1.79	19.9	0.43	357
ICON-010R/30-36	30	12	36	20:1	0.106	732	1.16	1.37	2.32	32.3	0.43	328
ICON-010R/30-48	30	12	48	20:1	0.142	975	0.99	1.16	2.42	46.4	0.47	306
ICON-010R/30-72	30	12	72	20:1	0.213	1463	0.86	1.26	3.47	67.0	0.56	318
ICON-010R/90-12	90	36	12	40:1	0.071	488	1.26	1.37	1.79	19.9	0.43	357
ICON-010R/90-18	90	36	18	40:1	0.106	732	1.16	1.37	2.32	32.3	0.43	328
ICON-010R/90-24	90	36	24	20:1	0.122	488	2.11	2.21	3.16	19.1	0.46	637
ICON-010R/90-36	90	36	36	20:1	0.184	732	1.68	2.00	3.89	40.5	0.41	454
ICON-010R/90-48	90	36	48	20:1	0.286	975	1.53	1.89	4.84	61.9	0.46	462
ICON-010R/90-72	90	36	72	20:1	0.367	1463	1.79	2.63	7.89	56.7	0.55	648
ICON-020R/180-18	180	72	18	40:1	0.184	732	1.68	2.00	3.89	40.5	0.41	454
ICON-020R/180-24	180	72	24	40:1	0.286	975	1.53	1.89	4.84	61.9	0.46	462
ICON-020R/180-36	180	72	36	40:1	0.367	1463	1.79	2.63	7.89	56.7	0.55	648
ICON-020R/180-48	180	72	48	20:1	0.526	975	3.26	4.11	10.32	57.0	0.43	924
ICON-020R/180-72	180	72	72	20:1	0.789	1463	2.84	4.53	12.63	69.1	0.61	1141
ICON-030R/360-24	360	144	24	40:1	0.526	975	3.26	4.11	10.32	57.0	0.43	924
ICON-030R/360-36	360	144	36	40:1	0.789	1463	2.84	4.53	12.63	69.1	0.61	1141
ICON-030R/360-48	360	144	48	20:1	1.123	975	5.68	12.74	20.53	69.8	0.43	1609
ICON-040R/720-24	720	288	24	40:1	1.123	975	5.68	12.74	20.53	69.8	0.43	1609

### NOTES

1. Inom – Actuator nominal current (at 40% set output torque) according to ISO 12590
2. Imax – Actuator current at max torque (100% set output torque) according to ISO 12590
3. Icc – Actuator locked rotor current (current measured with motor energized and output drive locked) according to ISO 12590
4. Absorbed power at nominal conditions (Watt)

## ON/OFF S2-30' OR INCHING SERVICE S4-25%, 600 STARTS/hr

Model	Nom. torque (100%) Nm	Min. torque (40%) Nm	Actuator		Motor power (kW)	Motor RPM	Motor <sup>[1]</sup>	Motor <sup>[2]</sup>	Locked <sup>[3]</sup>	Eff. % nom	Power factor	Absorbed <sup>[4]</sup> power (Watt)
			RPM	R			nominal current (Inom)	max current (Imax)	rotor current (Icc)			
ICON-010/30-144	30	12	144	20:1	0.426	2926	1.32	2.21	6.32	69.3	0.71	615
ICON-010/90-144	90	36	144	20:1	0.735	2926	2.32	4.63	12.63	72.0	0.67	1021
ICON-020/180-144	180	72	144	20:1	1.470	2926	4.21	7.89	24.21	79.2	0.67	1857
ICON-030/360-72	360	144	72	40:1	1.470	2926	4.21	7.89	24.21	79.2	0.67	1857
ICON-030/360-144	360	144	144	20:1	3.368	2926	9.26	18.53	54.74	81.2	0.68	4146
ICON-040/720-36	720	288	36	40:1	1.684	1463	4.53	6.84	31.58	84.4	0.67	1996
ICON-040/720-72	720	288	72	40:1	3.368	2926	9.26	18.53	54.74	81.2	0.68	4146

### NOTES

1. Inom – Actuator nominal current (at 40% set output torque) according to ISO 12590
2. Imax – Actuator current at max torque (100% set output torque) according to ISO 12590
3. Icc – Actuator locked rotor current (current measured with motor energized and output drive locked) according to ISO 12590
4. Absorbed power at nominal conditions (Watt)

# ICON 2000 ELECTRIC ACTUATORS

PERFORMANCE THREE PHASE SUPPLY 380 V / 60 Hz - 60 STARTS/hr

## ON/OFF S2-15' OR INCHING SERVICE S4-25%, 60 STARTS/hr

Model	Nom. torque (100%) Nm	Min. torque (40%) Nm	Actuator		Motor power (kW)	Motor RPM	Motor <sup>[1]</sup>	Motor <sup>[2]</sup>	Locked <sup>[3]</sup>	Eff. % nom	Power factor	Absorbed <sup>[4]</sup> power (Watt)
			RPM	R			nominal current (Inom)	max current (Imax)	rotor current (Icc)			
ICON-010/30-14	30	12	14	40:1	0.036	586	0.53	0.61	0.76	22.4	0.46	161
ICON-010/30-22	30	12	22	40:1	0.055	878	0.56	0.69	1.06	35.8	0.42	154
ICON-010/30-29	30	12	29	20:1	0.085	585	1.71	1.89	2.53	19.9	0.38	427
ICON-010/30-43	30	12	43	20:1	0.128	878	1.52	1.77	3.28	32.9	0.39	389
ICON-010/30-58	30	12	58	20:1	0.170	1170	1.19	1.39	2.84	46.3	0.47	367
ICON-010/30-86	30	12	86	20:1	0.255	1756	1.04	1.52	4.11	66.8	0.56	382
ICON-010/30-173	30	12	173	20:1	0.511	3511	1.58	2.65	7.45	69.3	0.71	738
ICON-010/90-14	90	36	14	40:1	0.085	585	1.71	1.89	2.53	19.9	0.38	427
ICON-010/90-22	90	36	22	40:1	0.128	878	1.52	1.77	3.28	32.9	0.39	389
ICON-010/90-29	90	36	29	20:1	0.147	585	2.78	3.03	4.42	19.1	0.42	768
ICON-010/90-43	90	36	43	20:1	0.220	878	2.02	2.53	5.56	40.3	0.41	545
ICON-010/90-58	90	36	58	20:1	0.343	1170	1.89	2.40	6.82	64.0	0.43	536
ICON-010/90-86	90	36	86	20:1	0.441	1756	2.15	3.16	10.86	62.4	0.50	707
ICON-010/90-173	90	36	173	20:1	0.882	3511	2.65	5.56	17.68	85.6	0.59	1030
ICON-020/180-22	180	72	22	40:1	0.220	878	2.02	2.53	5.56	40.3	0.41	545
ICON-020/180-29	180	72	29	40:1	0.343	1170	1.89	2.40	6.82	64.0	0.43	536
ICON-020/180-43	180	72	43	40:1	0.441	1756	2.15	3.16	10.86	62.4	0.50	707
ICON-020/180-58	180	72	58	20:1	0.631	1170	4.04	5.05	13.89	57.8	0.41	1091
ICON-020/180-86	180	72	86	20:1	0.946	1756	3.54	5.68	18.32	68.9	0.59	1373
ICON-020/180-173	180	72	173	20:1	1.764	3511	5.05	9.47	30.32	76.9	0.69	2295
ICON-030/360-14	360	144	14	80:1	0.631	1170	4.04	5.05	13.89	57.8	0.41	1091
ICON-030/360-29	360	144	29	40:1	0.631	1170	4.04	5.05	13.89	57.8	0.41	1091
ICON-030/360-43	360	144	43	40:1	0.946	1756	3.54	5.68	18.32	68.9	0.59	1373
ICON-030/360-58	360	144	58	20:1	1.347	1170	6.82	15.16	24.00	69.8	0.43	1930
ICON-030/360-86	360	144	86	40:1	1.764	3511	5.05	9.47	30.32	76.9	0.69	2295
ICON-030/360-173	360	144	173	20:1	4.042	3511	11.12	22.11	65.68	82.5	0.67	4902
ICON-040/720-14	720	288	14	80:1	1.347	1170	6.82	15.16	24.00	69.8	0.43	1930
ICON-040/720-29	720	288	29	40:1	1.347	1170	6.82	15.16	24.00	69.8	0.43	1930
ICON-040/720-43	720	288	43	40:1	2.021	1756	5.43	8.21	37.89	84.4	0.67	2395
ICON-040/720-58	720	288	58	20:1	2.327	1170	9.73	16.42	32.84	77.3	0.47	3009
ICON-040/720-86	720	288	86	40:1	4.042	3511	11.12	22.11	65.68	82.5	0.67	4902
ICON-040/720-173	720	288	173	20:1	6.982	3511	18.32	37.89	111.16	85.2	0.68	8197
ICON-050/1440-14	1440	576	14	80:1	2.327	1170	9.73	16.42	32.84	77.3	0.47	3009
ICON-050/1440-22	1440	576	22	80:1	2.021	1756	5.43	8.21	37.89	84.4	0.67	2395
ICON-050/1440-29	1440	576	29	40:1	2.327	1170	9.73	16.42	32.84	77.3	0.47	3009
ICON-050/1440-43	1440	576	43	40:1	3.462	1740	12.63	19.58	90.95	71.8	0.58	4822
ICON-050/1440-58	1440	576	58	20:1	4.655	1170	15.16	25.89	106.11	84.8	0.55	5487
ICON-050/1440-86	1440	576	86	40:1	6.982	3511	18.32	37.89	111.16	85.2	0.68	8197
ICON-050/1440-173	1440	576	173	20:1	13.964	3511	37.89	75.79	174.32	83.6	0.67	16711

### NOTES

1. Inom – Actuator nominal current (at 40% set output torque) according to ISO 12590
2. Imax – Actuator current at max torque (100% set output torque) according to ISO 12590
3. Icc – Actuator locked rotor current (current measured with motor energized and output drive locked) according to ISO 12590
4. Absorbed power at nominal conditions (Watt)

# ICON 2000 ELECTRIC ACTUATORS

PERFORMANCE THREE PHASE SUPPLY 415 V / 50 Hz - 60 STARTS/hr

## ON/OFF S2-15' OR INCHING SERVICE S4-25%, 60 STARTS/hr

Model	Nom. torque (100%) Nm	Min. torque (40%) Nm	Actuator		Motor power (kW)	Motor RPM	Motor <sup>[1]</sup>	Motor <sup>[2]</sup>	Locked <sup>[3]</sup>	Eff. % nom	Power factor	Absorbed <sup>[4]</sup> power (Watt)
			RPM	R			nominal current (Inom)	max current (Imax)	rotor current (Icc)			
ICON-010/30-12	30	12	12	40:1	0.030	488	0.40	0.46	0.63	22.4	0.46	134
ICON-010/30-18	30	12	18	40:1	0.046	732	0.42	0.53	0.82	35.9	0.42	128
ICON-010/30-24	30	12	24	20:1	0.071	488	1.16	1.25	1.64	19.9	0.43	357
ICON-010/30-36	30	12	36	20:1	0.106	732	1.06	1.25	2.12	32.3	0.43	328
ICON-010/30-48	30	12	48	20:1	0.142	975	0.91	1.06	2.22	46.4	0.47	306
ICON-010/30-72	30	12	72	20:1	0.213	1463	0.79	1.16	3.18	67.0	0.56	318
ICON-010/30-144	30	12	144	20:1	0.426	2926	1.20	2.02	5.78	69.3	0.71	615
ICON-010/90-12	90	36	12	40:1	0.071	488	1.16	1.25	1.64	19.9	0.43	357
ICON-010/90-18	90	36	18	40:1	0.106	732	1.06	1.25	2.12	32.3	0.43	328
ICON-010/90-24	90	36	24	20:1	0.122	488	1.93	2.02	2.89	19.1	0.46	637
ICON-010/90-36	90	36	36	20:1	0.184	732	1.54	1.83	3.57	40.5	0.41	454
ICON-010/90-48	90	36	48	20:1	0.286	975	1.40	1.73	4.43	61.9	0.46	462
ICON-010/90-72	90	36	72	20:1	0.367	1463	1.64	2.41	7.23	56.7	0.55	648
ICON-010/90-144	90	36	144	20:1	0.735	2926	2.12	4.24	11.57	72.0	0.67	1021
ICON-020/180-18	180	72	18	40:1	0.184	732	1.54	1.83	3.57	40.5	0.41	454
ICON-020/180-24	180	72	24	40:1	0.286	975	1.40	1.73	4.43	61.9	0.46	462
ICON-020/180-36	180	72	36	40:1	0.367	1463	1.64	2.41	7.23	56.7	0.55	648
ICON-020/180-48	180	72	48	20:1	0.526	975	2.99	3.76	9.45	57.0	0.43	924
ICON-020/180-72	180	72	72	20:1	0.789	1463	2.60	4.14	11.57	69.1	0.61	1141
ICON-020/180-144	180	72	144	20:1	1.470	2926	3.86	7.23	22.17	79.2	0.67	1857
ICON-030/360-12	360	144	12	80:1	0.526	975	2.99	3.76	9.45	57.0	0.43	924
ICON-030/360-24	360	144	24	40:1	0.526	975	2.99	3.76	9.45	57.0	0.43	924
ICON-030/360-48	360	144	48	20:1	1.123	975	5.20	11.66	18.80	69.8	0.43	1609
ICON-030/360-72	360	144	72	40:1	1.470	2926	3.86	7.23	22.17	79.2	0.67	1857
ICON-030/360-144	360	144	144	20:1	3.368	2926	8.48	16.96	50.12	81.2	0.68	4146
ICON-040/720-12	720	288	12	80:1	1.123	975	5.20	11.66	18.80	69.8	0.43	1609
ICON-040/720-24	720	288	24	40:1	1.123	975	5.20	11.66	18.80	69.8	0.43	1609
ICON-040/720-36	720	288	36	40:1	1.684	1463	4.14	6.27	28.92	84.4	0.67	1996
ICON-040/720-48	720	288	48	20:1	1.939	975	7.33	12.53	24.10	75.2	0.49	2580
ICON-040/720-72	720	288	72	40:1	3.368	2926	8.48	16.96	50.12	81.2	0.68	4146
ICON-040/720-144	720	288	144	20:1	5.818	2926	12.92	26.99	80.00	85.8	0.73	6777
ICON-050/1440-12	1440	576	12	80:1	1.939	975	7.33	12.53	24.10	75.2	0.49	2580
ICON-050/1440-18	1440	576	18	80:1	1.684	1463	4.14	6.27	28.92	84.4	0.67	1996
ICON-050/1440-24	1440	576	24	40:1	1.939	975	7.33	12.53	24.10	75.2	0.49	2580
ICON-050/1440-36	1440	576	36	40:1	2.885	1449	8.92	14.46	67.47	80.4	0.56	3589
ICON-050/1440-48	1440	576	48	20:1	3.879	975	10.60	18.31	77.11	83.4	0.61	4649
ICON-050/1440-72	1440	576	72	40:1	5.818	2926	12.92	26.99	80.00	85.8	0.73	6777
ICON-050/1440-144	1440	576	144	20:1	11.636	2926	26.51	54.94	125.30	86.0	0.71	13527

### NOTES

1. Inom – Actuator nominal current (at 40% set output torque) according to ISO 12590
2. Imax – Actuator current at max torque (100% set output torque) according to ISO 12590
3. Icc – Actuator locked rotor current (current measured with motor energized and output drive locked) according to ISO 12590
4. Absorbed power at nominal conditions (Watt)

# ICON 2000 ELECTRIC ACTUATORS

PERFORMANCE THREE PHASE SUPPLY 415 V / 50 Hz - 600 TO 1200 STARTS/hr

## ON/OFF S2-30' OR INCHING SERVICE S4-25%, 600 STARTS/hr; MODULATING SERVICE S4-50%, 1200 STARTS/hr

Model	Nom. torque (100%) Nm	Min. torque (40%) Nm	Actuator RPM	R	Motor power (kW)	Motor RPM	Motor <sup>[1]</sup>	Motor <sup>[2]</sup>	Locked <sup>[3]</sup>	Eff. % nom	Power factor	Absorbed <sup>[4]</sup> power (Watt)
							nominal current (Inom)	max current (Imax)	rotor current (Icc)			
ICON-010R/30-12	30	12	12	40:1	0.030	488	0.40	0.46	0.63	22.4	0.46	134
ICON-010R/30-18	30	12	18	40:1	0.046	732	0.42	0.53	0.82	35.9	0.42	128
ICON-010R/30-24	30	12	24	20:1	0.071	488	1.16	1.25	1.64	19.9	0.43	357
ICON-010R/30-36	30	12	36	20:1	0.106	732	1.06	1.25	2.12	32.3	0.43	328
ICON-010R/30-48	30	12	48	20:1	0.142	975	0.91	1.06	2.22	46.4	0.47	306
ICON-010R/30-72	30	12	72	20:1	0.213	1463	0.79	1.16	3.18	67.0	0.56	318
ICON-010R/90-12	90	36	12	40:1	0.071	488	1.16	1.25	1.64	19.9	0.43	357
ICON-010R/90-18	90	36	18	40:1	0.106	732	1.06	1.25	2.12	32.3	0.43	328
ICON-010R/90-24	90	36	24	20:1	0.122	488	1.93	2.02	2.89	19.1	0.46	637
ICON-010R/90-36	90	36	36	20:1	0.184	732	1.54	1.83	3.57	40.5	0.41	454
ICON-010R/90-48	90	36	48	20:1	0.286	975	1.40	1.73	4.43	61.9	0.46	462
ICON-010R/90-72	90	36	72	20:1	0.367	1463	1.64	2.41	7.23	56.7	0.55	648
ICON-020R/180-18	180	72	18	40:1	0.184	732	1.54	1.83	3.57	40.5	0.41	454
ICON-020R/180-24	180	72	24	40:1	0.286	975	1.40	1.73	4.43	61.9	0.46	462
ICON-020R/180-36	180	72	36	40:1	0.367	1463	1.64	2.41	7.23	56.7	0.55	648
ICON-020R/180-48	180	72	48	20:1	0.526	975	2.99	3.76	9.45	57.0	0.43	924
ICON-020R/180-72	180	72	72	20:1	0.789	1463	2.60	4.14	11.57	69.1	0.61	1141
ICON-030R/360-24	360	144	24	40:1	0.526	975	2.99	3.76	9.45	57.0	0.43	924
ICON-030R/360-36	360	144	36	40:1	0.789	1463	2.60	4.14	11.57	69.1	0.61	1141
ICON-030R/360-48	360	144	48	20:1	1.123	975	5.20	11.66	18.80	69.8	0.43	1609
ICON-040R/720-24	720	288	24	40:1	1.123	975	5.20	11.66	18.80	69.8	0.43	1609

### NOTES

1. Inom – Actuator nominal current (at 40% set output torque) according to ISO 12590
2. Imax – Actuator current at max torque (100% set output torque) according to ISO 12590
3. Icc – Actuator locked rotor current (current measured with motor energized and output drive locked) according to ISO 12590
4. Absorbed power at nominal conditions (Watt)

## ON/OFF S2-30' OR INCHING SERVICE S4-25%, 600 STARTS/hr

Model	Nom. torque (100%) Nm	Min. torque (40%) Nm	Actuator RPM	R	Motor power (kW)	Motor RPM	Motor <sup>[1]</sup>	Motor <sup>[2]</sup>	Locked <sup>[3]</sup>	Eff. % nom	Power factor	Absorbed <sup>[4]</sup> power (Watt)
							nominal current (Inom)	max current (Imax)	rotor current (Icc)			
ICON-010/30-144	30	12	144	20:1	0.426	2926	1.20	2.02	5.78	69.3	0.71	615
ICON-010/90-144	90	36	144	20:1	0.735	2926	2.12	4.24	11.57	72.0	0.67	1021
ICON-020/180-144	180	72	144	20:1	1.470	2926	3.86	7.23	22.17	79.2	0.67	1857
ICON-030/360-72	360	144	72	40:1	1.470	2926	3.86	7.23	22.17	79.2	0.67	1857
ICON-030/360-144	360	144	144	20:1	3.368	2926	8.48	16.96	50.12	81.2	0.68	4146
ICON-040/720-36	720	288	36	40:1	1.684	1463	4.14	6.27	28.92	84.4	0.67	1996
ICON-040/720-72	720	288	72	40:1	3.368	2926	8.48	16.96	50.12	81.2	0.68	4146

### NOTES

1. Inom – Actuator nominal current (at 40% set output torque) according to ISO 12590
2. Imax – Actuator current at max torque (100% set output torque) according to ISO 12590
3. Icc – Actuator locked rotor current (current measured with motor energized and output drive locked) according to ISO 12590
4. Absorbed power at nominal conditions (Watt)

# ICON 2000 ELECTRIC ACTUATORS

PERFORMANCE THREE PHASE SUPPLY 415 V / 60 Hz - 60 STARTS/hr

## ON/OFF S2-15' OR INCHING SERVICE S4-25%, 60 STARTS/hr

Model	Nom. torque (100%) Nm	Min. torque (40%) Nm	Actuator		Motor power (kW)	Motor RPM	Motor <sup>[1]</sup>	Motor <sup>[2]</sup>	Locked <sup>[3]</sup>	Eff. % nom	Power factor	Absorbed <sup>[4]</sup> power (Watt)
			RPM	R			nominal current (Inom)	max current (Imax)	rotor current (Icc)			
ICON-010/30-14	30	12	14	40:1	0.036	586	0.49	0.56	0.69	22.4	0.46	161
ICON-010/30-22	30	12	22	40:1	0.055	878	0.51	0.64	0.97	35.8	0.42	154
ICON-010/30-29	30	12	29	20:1	0.085	585	1.56	1.73	2.31	19.9	0.38	427
ICON-010/30-43	30	12	43	20:1	0.128	878	1.39	1.62	3.01	32.9	0.39	389
ICON-010/30-58	30	12	58	20:1	0.170	1170	1.09	1.27	2.60	46.3	0.47	367
ICON-010/30-86	30	12	86	20:1	0.255	1756	0.95	1.39	3.76	66.8	0.56	382
ICON-010/30-173	30	12	173	20:1	0.511	3511	1.45	2.43	6.82	69.3	0.71	738
ICON-010/90-14	90	36	14	40:1	0.085	585	1.56	1.73	2.31	19.9	0.38	427
ICON-010/90-22	90	36	22	40:1	0.128	878	1.39	1.62	3.01	32.9	0.39	389
ICON-010/90-29	90	36	29	20:1	0.147	585	2.54	2.78	4.05	19.1	0.42	768
ICON-010/90-43	90	36	43	20:1	0.220	878	1.85	2.31	5.09	40.3	0.41	545
ICON-010/90-58	90	36	58	20:1	0.343	1170	1.73	2.20	6.25	64.0	0.43	536
ICON-010/90-86	90	36	86	20:1	0.441	1756	1.97	2.89	9.95	62.4	0.50	707
ICON-010/90-173	90	36	173	20:1	0.882	3511	2.43	5.09	16.19	85.6	0.59	1030
ICON-020/180-22	180	72	22	40:1	0.220	878	1.85	2.31	5.09	40.3	0.41	545
ICON-020/180-29	180	72	29	40:1	0.343	1170	1.73	2.20	6.25	64.0	0.43	536
ICON-020/180-43	180	72	43	40:1	0.441	1756	1.97	2.89	9.95	62.4	0.50	707
ICON-020/180-58	180	72	58	20:1	0.631	1170	3.70	4.63	12.72	57.8	0.41	1091
ICON-020/180-86	180	72	86	20:1	0.946	1756	3.24	5.20	16.77	68.9	0.59	1373
ICON-020/180-173	180	72	173	20:1	1.764	3511	4.63	8.67	27.76	76.9	0.69	2295
ICON-030/360-14	360	144	14	80:1	0.631	1170	3.70	4.63	12.72	57.8	0.41	1091
ICON-030/360-29	360	144	29	40:1	0.631	1170	3.70	4.63	12.72	57.8	0.41	1091
ICON-030/360-43	360	144	43	40:1	0.946	1756	3.24	5.20	16.77	68.9	0.59	1373
ICON-030/360-58	360	144	58	20:1	1.347	1170	6.25	13.88	21.98	69.8	0.43	1930
ICON-030/360-86	360	144	86	40:1	1.764	3511	4.63	8.67	27.76	76.9	0.69	2295
ICON-030/360-173	360	144	173	20:1	4.042	3511	10.18	20.24	60.14	82.5	0.67	4902
ICON-040/720-14	720	288	14	80:1	1.347	1170	6.25	13.88	21.98	69.8	0.43	1930
ICON-040/720-29	720	288	29	40:1	1.347	1170	6.25	13.88	21.98	69.8	0.43	1930
ICON-040/720-43	720	288	43	40:1	2.021	1756	4.97	7.52	34.70	84.4	0.67	2395
ICON-040/720-58	720	288	58	20:1	2.327	1170	8.91	15.04	30.07	77.3	0.47	3009
ICON-040/720-86	720	288	86	40:1	4.042	3511	10.18	20.24	60.14	82.5	0.67	4902
ICON-040/720-173	720	288	173	20:1	6.982	3511	16.77	34.70	101.78	85.2	0.68	8197
ICON-050/1440-14	1440	576	14	80:1	2.327	1170	8.91	15.04	30.07	77.3	0.47	3009
ICON-050/1440-22	1440	576	22	80:1	2.021	1756	4.97	7.52	34.70	84.4	0.67	2395
ICON-050/1440-29	1440	576	29	40:1	2.327	1170	8.91	15.04	30.07	77.3	0.47	3009
ICON-050/1440-43	1440	576	43	40:1	3.462	1740	11.57	17.93	83.28	71.8	0.58	4822
ICON-050/1440-58	1440	576	58	20:1	4.655	1170	13.88	23.71	97.16	84.8	0.55	5487
ICON-050/1440-86	1440	576	86	40:1	6.982	3511	16.77	34.70	101.78	85.2	0.68	8197
ICON-050/1440-173	1440	576	173	20:1	13.964	3511	34.70	69.40	159.61	83.6	0.67	16711

### NOTES

1. Inom – Actuator nominal current (at 40% set output torque) according to ISO 12590
2. Imax – Actuator current at max torque (100% set output torque) according to ISO 12590
3. Icc – Actuator locked rotor current (current measured with motor energized and output drive locked) according to ISO 12590
4. Absorbed power at nominal conditions (Watt)



# ICON 2000 ELECTRIC ACTUATORS

PERFORMANCE THREE PHASE SUPPLY 440 V / 50 Hz - 600 TO 1200 STARTS/hr

## ON/OFF S2-30' OR INCHING SERVICE S4-25%, 600 STARTS/hr; MODULATING SERVICE S4-50%, 1200 STARTS/hr

Model	Nom. torque (100%) Nm	Min. torque (40%) Nm	Actuator		Motor		Motor <sup>[1]</sup>	Motor <sup>[2]</sup>	Locked <sup>[3]</sup>	Eff. % nom	Power factor	Absorbed <sup>[4]</sup> power (Watt)
			RPM	R	power (kW)	RPM	nominal current (Inom)	max current (Imax)	rotor current (Icc)			
ICON-010R/30-12	30	12	12	40:1	0.030	488	0.38	0.44	0.59	22.4	0.46	134
ICON-010R/30-18	30	12	18	40:1	0.046	732	0.40	0.50	0.77	35.9	0.42	128
ICON-010R/30-24	30	12	24	20:1	0.071	488	1.09	1.18	1.55	19.9	0.43	357
ICON-010R/30-36	30	12	36	20:1	0.106	732	1.00	1.18	2.00	32.3	0.43	328
ICON-010R/30-48	30	12	48	20:1	0.142	975	0.85	1.00	2.09	46.4	0.47	306
ICON-010R/30-72	30	12	72	20:1	0.213	1463	0.75	1.09	3.00	67.0	0.56	318
ICON-010R/90-12	90	36	12	40:1	0.071	488	1.09	1.18	1.55	19.9	0.43	357
ICON-010R/90-18	90	36	18	40:1	0.106	732	1.00	1.18	2.00	32.3	0.43	328
ICON-010R/90-24	90	36	24	20:1	0.122	488	1.82	1.91	2.73	19.1	0.46	637
ICON-010R/90-36	90	36	36	20:1	0.184	732	1.45	1.73	3.36	40.5	0.41	454
ICON-010R/90-48	90	36	48	20:1	0.286	975	1.32	1.64	4.18	61.9	0.46	462
ICON-010R/90-72	90	36	72	20:1	0.367	1463	1.55	2.27	6.82	56.7	0.55	648
ICON-020R/180-18	180	72	18	40:1	0.184	732	1.45	1.73	3.36	40.5	0.41	454
ICON-020R/180-24	180	72	24	40:1	0.286	975	1.32	1.64	4.18	61.9	0.46	462
ICON-020R/180-36	180	72	36	40:1	0.367	1463	1.55	2.27	6.82	56.7	0.55	648
ICON-020R/180-48	180	72	48	20:1	0.526	975	2.82	3.55	8.91	57.0	0.43	924
ICON-020R/180-72	180	72	72	20:1	0.789	1463	2.45	3.91	10.91	69.1	0.61	1141
ICON-030R/360-24	360	144	24	40:1	0.526	975	2.82	3.55	8.91	57.0	0.43	924
ICON-030R/360-36	360	144	36	40:1	0.789	1463	2.45	3.91	10.91	69.1	0.61	1141
ICON-030R/360-48	360	144	48	20:1	1.123	975	4.91	11.00	17.73	69.8	0.43	1609
ICON-040R/720-24	720	288	24	40:1	1.123	975	4.91	11.00	17.73	69.8	0.43	1609

### NOTES

1. Inom – Actuator nominal current (at 40% set output torque) according to ISO 12590
2. Imax – Actuator current at max torque (100% set output torque) according to ISO 12590
3. Icc – Actuator locked rotor current (current measured with motor energized and output drive locked) according to ISO 12590
4. Absorbed power at nominal conditions (Watt)

## ON/OFF S2-30' OR INCHING SERVICE S4-25%, 600 STARTS/hr

Model	Nom. torque (100%) Nm	Min. torque (40%) Nm	Actuator		Motor		Motor <sup>[1]</sup>	Motor <sup>[2]</sup>	Locked <sup>[3]</sup>	Eff. % nom	Power factor	Absorbed <sup>[4]</sup> power (Watt)
			RPM	R	power (kW)	RPM	nominal current (Inom)	max current (Imax)	rotor current (Icc)			
ICON-010/30-144	30	12	144	20:1	0.426	2926	1.14	1.91	5.45	69.3	0.71	615
ICON-010/90-144	90	36	144	20:1	0.735	2926	2.00	4.00	10.91	72.0	0.67	1021
ICON-020/180-144	180	72	144	20:1	1.470	2926	3.64	6.82	20.91	79.2	0.67	1857
ICON-030/360-72	360	144	72	40:1	1.470	2926	3.64	6.82	20.91	79.2	0.67	1857
ICON-030/360-144	360	144	144	20:1	3.368	2926	8.00	16.00	47.27	81.2	0.68	4146
ICON-040/720-36	720	288	36	40:1	1.684	1463	3.91	5.91	27.27	84.4	0.67	1996
ICON-040/720-72	720	288	72	40:1	3.368	2926	8.00	16.00	47.27	81.2	0.68	4146

### NOTES

1. Inom – Actuator nominal current (at 40% set output torque) according to ISO 12590
2. Imax – Actuator current at max torque (100% set output torque) according to ISO 12590
3. Icc – Actuator locked rotor current (current measured with motor energized and output drive locked) according to ISO 12590
4. Absorbed power at nominal conditions (Watt)

# ICON 2000 ELECTRIC ACTUATORS

PERFORMANCE THREE PHASE SUPPLY 460 V / 60 Hz - 60 STARTS/hr

## ON/OFF S2-15' OR INCHING SERVICE S4-25%, 60 STARTS/hr

Model	Nom. torque (100%) Nm	Min. torque (40%) Nm	Actuator		Motor power (kW)	Motor RPM	Motor <sup>[1]</sup>	Motor <sup>[2]</sup>	Locked <sup>[3]</sup>	Eff. % nom	Power factor	Absorbed <sup>[4]</sup> power (Watt)
			RPM	R			nominal current (Inom)	max current (Imax)	rotor current (Icc)			
ICON-010/30-14	30	12	14	40:1	0.036	586	0.44	0.50	0.63	22.4	0.46	161
ICON-010/30-22	30	12	22	40:1	0.055	878	0.46	0.57	0.88	35.8	0.42	154
ICON-010/30-29	30	12	29	20:1	0.085	585	1.41	1.57	2.09	19.9	0.38	427
ICON-010/30-43	30	12	43	20:1	0.128	878	1.25	1.46	2.71	32.9	0.39	389
ICON-010/30-58	30	12	58	20:1	0.170	1170	0.98	1.15	2.35	46.3	0.47	367
ICON-010/30-86	30	12	86	20:1	0.255	1756	0.86	1.25	3.39	66.8	0.56	382
ICON-010/30-173	30	12	173	20:1	0.511	3511	1.30	2.19	6.16	69.3	0.71	738
ICON-010/90-14	90	36	14	40:1	0.085	585	1.41	1.57	2.09	19.9	0.38	427
ICON-010/90-22	90	36	22	40:1	0.128	878	1.25	1.46	2.71	32.9	0.39	389
ICON-010/90-29	90	36	29	20:1	0.147	585	2.30	2.50	3.65	19.1	0.42	768
ICON-010/90-43	90	36	43	20:1	0.220	878	1.67	2.09	4.59	40.3	0.41	545
ICON-010/90-58	90	36	58	20:1	0.343	1170	1.57	1.98	5.63	64.0	0.43	536
ICON-010/90-86	90	36	86	20:1	0.441	1756	1.77	2.61	8.97	62.4	0.50	707
ICON-010/90-173	90	36	173	20:1	0.882	3511	2.19	4.59	14.61	85.6	0.59	1030
ICON-020/180-22	180	72	22	40:1	0.220	878	1.67	2.09	4.59	40.3	0.41	545
ICON-020/180-29	180	72	29	40:1	0.343	1170	1.57	1.98	5.63	64.0	0.43	536
ICON-020/180-43	180	72	43	40:1	0.441	1756	1.77	2.61	8.97	62.4	0.50	707
ICON-020/180-58	180	72	58	20:1	0.631	1170	3.34	4.17	11.48	57.8	0.41	1091
ICON-020/180-86	180	72	86	20:1	0.946	1756	2.92	4.70	15.13	68.9	0.59	1373
ICON-020/180-173	180	72	173	20:1	1.764	3511	4.17	7.83	25.04	76.9	0.69	2295
ICON-030/360-14	360	144	14	80:1	0.631	1170	3.34	4.17	11.48	57.8	0.41	1091
ICON-030/360-22	360	144	22	40:1	0.600	875	3.03	5.32	10.23	69.2	0.36	867
ICON-030/360-29	360	144	29	40:1	0.631	1170	3.34	4.17	11.48	57.8	0.41	1091
ICON-030/360-43	360	144	43	40:1	0.946	1756	2.92	4.70	15.13	68.9	0.59	1373
ICON-030/360-58	360	144	58	20:1	1.347	1170	5.63	12.52	19.83	69.8	0.43	1930
ICON-030/360-86	360	144	86	40:1	1.764	3511	4.17	7.83	25.04	76.9	0.69	2295
ICON-030/360-173	360	144	173	20:1	4.042	3511	9.18	18.26	54.26	82.5	0.67	4902
ICON-040/720-14	720	288	14	80:1	1.347	1170	5.63	12.52	19.83	69.8	0.43	1930
ICON-040/720-29	720	288	29	40:1	1.347	1170	5.63	12.52	19.83	69.8	0.43	1930
ICON-040/720-43	720	288	43	40:1	2.021	1756	4.49	6.78	31.30	84.4	0.67	2395
ICON-040/720-58	720	288	58	20:1	2.327	1170	8.03	13.57	27.13	77.3	0.47	3009
ICON-040/720-86	720	288	86	40:1	4.042	3511	9.18	18.26	54.26	82.5	0.67	4902
ICON-040/720-173	720	288	173	20:1	6.982	3511	15.13	31.30	91.83	85.2	0.68	8197
ICON-050/1440-14	1440	576	14	80:1	2.327	1170	8.03	13.57	27.13	77.3	0.47	3009
ICON-050/1440-22	1440	576	22	80:1	2.021	1756	4.49	6.78	31.30	84.4	0.67	2395
ICON-050/1440-29	1440	576	29	40:1	2.327	1170	8.03	13.57	27.13	77.3	0.47	3009
ICON-050/1440-43	1440	576	43	40:1	3.462	1739	9.65	16.25	73.00	80.4	0.56	4306
ICON-050/1440-58	1440	576	58	20:1	4.655	1170	12.52	21.39	87.65	84.8	0.55	5487
ICON-050/1440-86	1440	576	86	40:1	6.982	3511	15.13	31.30	91.83	85.2	0.68	8197
ICON-050/1440-173	1440	576	173	20:1	13.964	3511	31.30	62.61	144.00	83.6	0.67	16711

### NOTES

1. Inom – Actuator nominal current (at 40% set output torque) according to ISO 12590
2. Imax – Actuator current at max torque (100% set output torque) according to ISO 12590
3. Icc – Actuator locked rotor current (current measured with motor energized and output drive locked) according to ISO 12590
4. Absorbed power at nominal conditions (Watt)

# ICON 2000 ELECTRIC ACTUATORS

## PERFORMANCE 24 V & 48 V DC SUPPLY

### 24 V DC - ON/OFF S2-15' OR INCHING SERVICE S4-25%, 600 STARTS/hr

Model	Nom. torque (100%) Nm	Min. torque (40%) Nm	Actuator RPM	R	Motor power (kW)	Motor <sup>[3]</sup>	Motor <sup>[4]</sup>	Locked <sup>[5]</sup>	Absorbed <sup>[6]</sup>
						nominal current (Inom)	max current (Imax)	rotor current (Icc)	power (Watt)
ICON-010D/ 30-SR1	30	12	12 - 30	40:1	0.400	12.00	18.00	60.00	443
ICON-010D/ 30-SR2	30	12	30 - 60	20:1	0.400	19.00	25.00	90.00	702
ICON-010D/ 90-SR1	90	36	12 - 30	40:1	0.400	24.00	37.00	80.00	886
ICON-010D/ 90-SR2	90	36	50 - 68	20:1	0.400	38.00	80.00	100.00	1403

#### NOTES

1. Permanent magnet motor with brushes
2. The last digits in the model number represent the range of adjustable output speed (RPM) shown on the table
3. Inom – Actuator nominal current (at 40% set output torque) according to ISO 12590
4. Imax – Actuator current at max torque (100% set output torque) according to ISO 12590
5. Icc – Actuator locked rotor current (current measured with motor energized and output drive locked) according to ISO 12590
6. Absorbed power at nominal conditions (Watt)

### 48 V DC - ON/OFF S2-15' OR INCHING SERVICE S4-25%, 600 STARTS/hr

Model	Nom. torque (100%) Nm	Min. torque (40%) Nm	Actuator RPM	R	Motor power (kW)	Motor <sup>[3]</sup>	Motor <sup>[4]</sup>	Locked <sup>[5]</sup>	Absorbed <sup>[6]</sup>
						nominal current (Inom)	max current (Imax)	rotor current (Icc)	power (Watt)
ICON-010D/ 30-SR1	30	12	12 - 30	40:1	0.400	9.50	10.00	58.00	335
ICON-010D/ 30-SR2	30	12	30 - 60	20:1	0.400	12.00	13.00	65.00	424
ICON-010D/ 90-SR1	90	36	12 - 30	40:1	0.400	13.00	19.00	48.00	459
ICON-010D/ 90-SR2	90	36	50 - 68	20:1	0.400	17.00	35.00	58.00	600

#### NOTES

1. Permanent magnet motor with brushes
2. The last digits in the model number represent the range of adjustable output speed (RPM) shown on the table
3. Inom – Actuator nominal current (at 40% set output torque) according to ISO 12590
4. Imax – Actuator current at max torque (100% set output torque) according to ISO 12590
5. Icc – Actuator locked rotor current (current measured with motor energized and output drive locked) according to ISO 12590
6. Absorbed power at nominal conditions (Watt)

### 24 VDC LOW POWER

Model	Actuator (RPM)	Motor Type	Motor Power (KW)	Motor <sup>[3]</sup>	Motor <sup>[4]</sup>	Locked <sup>[5]</sup>	Absorbed <sup>[6]</sup>
				nominal current (Inom)	Max current (Imax)	rotor current (Icc)	power (Watt)
ICON-010LP/ 30-SR1 <sup>[7.1]</sup>	0,5 - 2,2	LP0B	0,075	0,50	1,00	2,87	12
ICON-010LP/ 30-SR2 <sup>[7.2]</sup>	1,6 - 8	LP0A	0,115	1,60	4,10	5,32	29

#### NOTES

1. Permanent magnets motor with brushes
2. The last digits in the model number represent the range of adjustable output speed (RPM) shown on the table
3. Inom – Actuator nominal current (at 40% set output torque) according to ISO 12590
4. Imax – Actuator current at max torque (100% set output torque) according to ISO 12590
5. Icc – Actuator locked rotor current (current measured with motor energized and output drive locked) according to ISO 12590
6. Absorbed Power (Watt) at Nominal Conditions with maximum actuator speed
- 7.1. Nominal Duty S2-60' or S4-50% 1200 starts/hours at Pnom/Unom (-5%;+5%) acc. to CEI 2-3 (eq. to IEC 60034-1)
- 7.2. Nominal Duty S2-20' or S4-50% 1200 starts/hours at Pnom/Unom (-5%;+5%) acc. to CEI 2-3 (eq. to IEC 60034-1)
8. Electrical characteristics are referred to the actuator running at maximum allowable speed of the speed range of the model

# ICON 2000 ELECTRIC ACTUATORS

## PERFORMANCE 110 V & 120 V DC SUPPLY

### 110 V DC - ON/OFF S2-15' OR INCHING SERVICE S4-25%, 600 STARTS/hr

Model	Nom. torque (100%) Nm	Min. torque (40%) Nm	Actuator		Motor power (kW)	Motor <sup>[3]</sup>	Motor <sup>[4]</sup>	Locked <sup>[5]</sup>	Absorbed <sup>[6]</sup>
			RPM	R		nominal current (Inom)	max current (Imax)	rotor current (Icc)	power (Watt)
ICON-010D/ 30-SR1	30	12	12 - 30	40:1	0.400	5.20	7.50	25.00	572
ICON-010D/ 30-SR2	30	12	30 - 80	20:1	0.400	5.80	7.70	25.00	638
ICON-010D/ 90-SR1	90	36	20 - 40	40:1	0.400	5.20	9.00	25.00	572
ICON-010D/ 90-SR2	90	36	55 - 70	20:1	0.400	6.00	12.00	25.00	660
ICON-020D/180-SR1	180	72	35 - 37	40:1	0.400	7.20	17.50	25.00	792

#### NOTES

1. Permanent magnet motor with brushes
2. The last digits in the model number represent the range of adjustable output speed (RPM) shown on the table
3. Inom – Actuator nominal current (at 40% set output torque) according to ISO 12590
4. Imax – Actuator current at max torque (100% set output torque) according to ISO 12590
5. Icc – Actuator locked rotor current (current measured with motor energized and output drive locked) according to ISO 12590
6. Absorbed power at nominal conditions (Watt)

### 120 V DC - ON/OFF S2-15' OR INCHING SERVICE S4-25%, 600 STARTS/hr

Model	Nom. torque (100%) Nm	Min. torque (40%) Nm	Actuator		Motor power (kW)	Motor <sup>[3]</sup>	Motor <sup>[4]</sup>	Locked <sup>[5]</sup>	Absorbed <sup>[6]</sup>
			RPM	R		nominal current (Inom)	max current (Imax)	rotor current (Icc)	power (Watt)
ICON-010D/ 30-SR1	30	12	12 - 30	40:1	0.400	4.80	7.50	25.00	576
ICON-010D/ 30-SR2	30	12	30 - 80	20:1	0.400	5.40	7.70	25.00	648
ICON-010D/ 90-SR1	90	36	20 - 40	40:1	0.400	4.80	9.00	25.00	576
ICON-010D/ 90-SR2	90	36	55 - 70	20:1	0.400	5.50	12.00	25.00	660
ICON-020D/180-SR1	180	72	35 - 37	40:1	0.400	6.60	17.50	25.00	792

#### NOTES

1. Permanent magnet motor with brushes
2. The last digits in the model number represent the range of adjustable output speed (RPM) shown on the table
3. Inom – Actuator nominal current (at 40% set output torque) according to ISO 12590
4. Imax – Actuator current at max torque (100% set output torque) according to ISO 12590
5. Icc – Actuator locked rotor current (current measured with motor energized and output drive locked) according to ISO 12590
6. Absorbed power at nominal conditions (Watt)

# ICON 2000 ELECTRIC ACTUATORS

## OVERALL DIMENSIONS - STANDARD MANUAL OVERRIDE

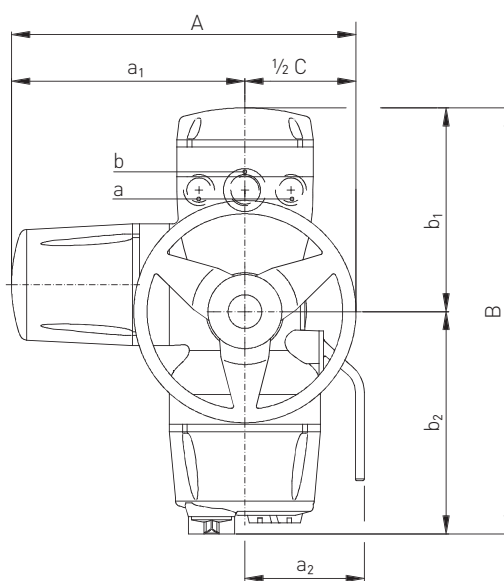
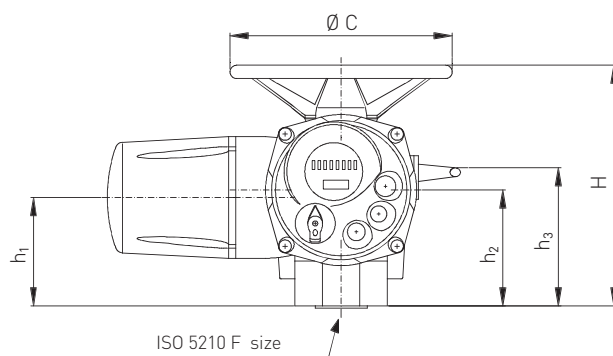

Standard cable entries:  
 a = 2 x 1" NPT  
 b = 1 x 1½" NPT  
 Metric options available on request

### ICON 2000 SERIES STANDARD MANUAL OVERRIDE - METRIC (mm / kg)

Model	A	a <sub>1</sub>	a <sub>2</sub>	B	b <sub>1</sub>	b <sub>2</sub>	Ø C	F	H	h <sub>1</sub>	h <sub>2</sub>	h <sub>3</sub>	Mass (kg)
ICON-010	484	325	159	561	273	288	300	F10	332	142	152	209	32
ICON-020	597	347	159	579	283	296	500	F14	380	161	161	239	45
ICON-030	699	399	159	621	313	308	600	F14	436	175	175	269	70
ICON-040	815	455	159	686	318	368	720	F16	486	196	191	291	86
ICON-050	958	528	159	750	363	387	860	F25	560	223	218	336	110

# ICON 2000 ELECTRIC ACTUATORS

## OVERALL DIMENSIONS - REDUCED MANUAL OVERRIDE

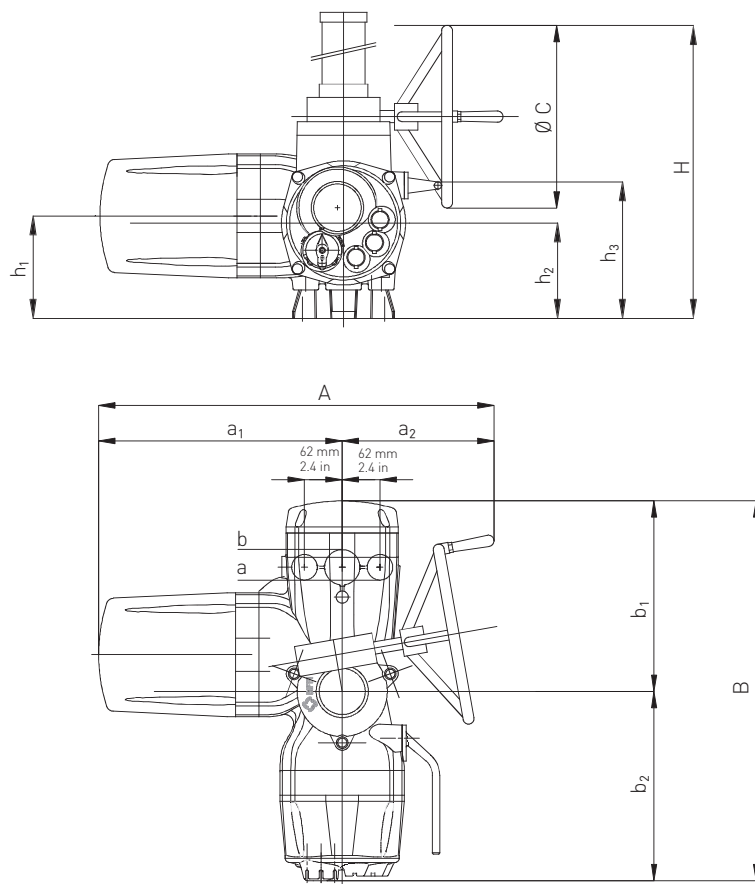

Standard cable entries:  
 $a = 2 \times 1''$  NPT  
 $b = 1 \times 1\frac{1}{2}''$  NPT  
 Metric options available on request

### ICON 2000 SERIES WITH REDUCED MANUAL OVERRIDE - METRIC (mm / kg)

Model	A	a <sub>1</sub>	a <sub>2</sub>	B	b <sub>1</sub>	b <sub>2</sub>	Ø C	H	h <sub>1</sub>	h <sub>2</sub>	h <sub>3</sub>	Manual override	
												R	Mass (kg)
ICON-030	648	399	249	621	313	308	300	500	175	175	269	10 / 1	78
ICON-040	723	455	268	686	318	368	400	574	196	191	291	13 / 1	94
ICON-050	799	528	271	750	363	387	500	685	223	218	336	17 / 1	118

# ICON 2000 ELECTRIC ACTUATORS

## OVERALL DIMENSIONS - OPTIONAL PROFIBUS MODULE WITH STANDARD MANUAL OVERRIDE

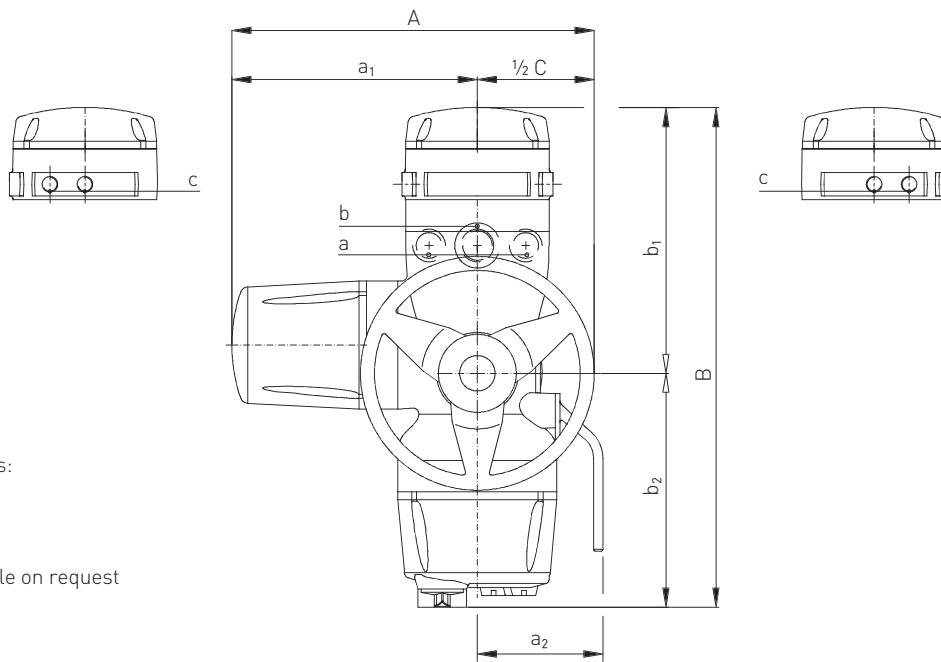
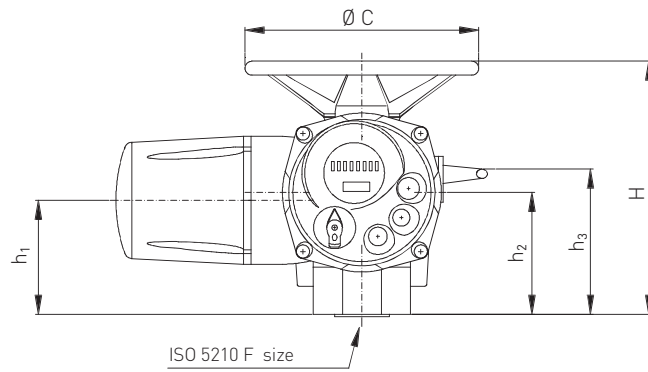

Standard cable entries:  
 a = 2 x 1" NPT  
 b = 1 x 1½" NPT  
 c = 4 x ½" NPT  
 Metric options available on request

### ICON 2000 SERIES WITH DETACHABLE PROFIBUS - METRIC (mm / kg)

Model	A	a <sub>1</sub>	a <sub>2</sub>	B	b <sub>1</sub>	b <sub>2</sub>	Ø C	F	H	h <sub>1</sub>	h <sub>2</sub>	h <sub>3</sub>	Mass (kg)
ICON-010	484	325	159	627	339	288	300	F10	332	142	152	209	38
ICON-020	597	347	159	645	349	296	500	F14	380	161	161	239	51
ICON-030	699	399	159	687	379	308	600	F14	436	175	175	269	76
ICON-040	815	455	159	752	384	368	720	F16	486	196	191	291	92
ICON-050	958	528	159	816	432	387	860	F25	560	223	218	336	116

# ICON 2000 ELECTRIC ACTUATORS

## OVERALL DIMENSIONS - OPTIONAL PROFIBUS MODULE WITH REDUCED MANUAL OVERRIDE

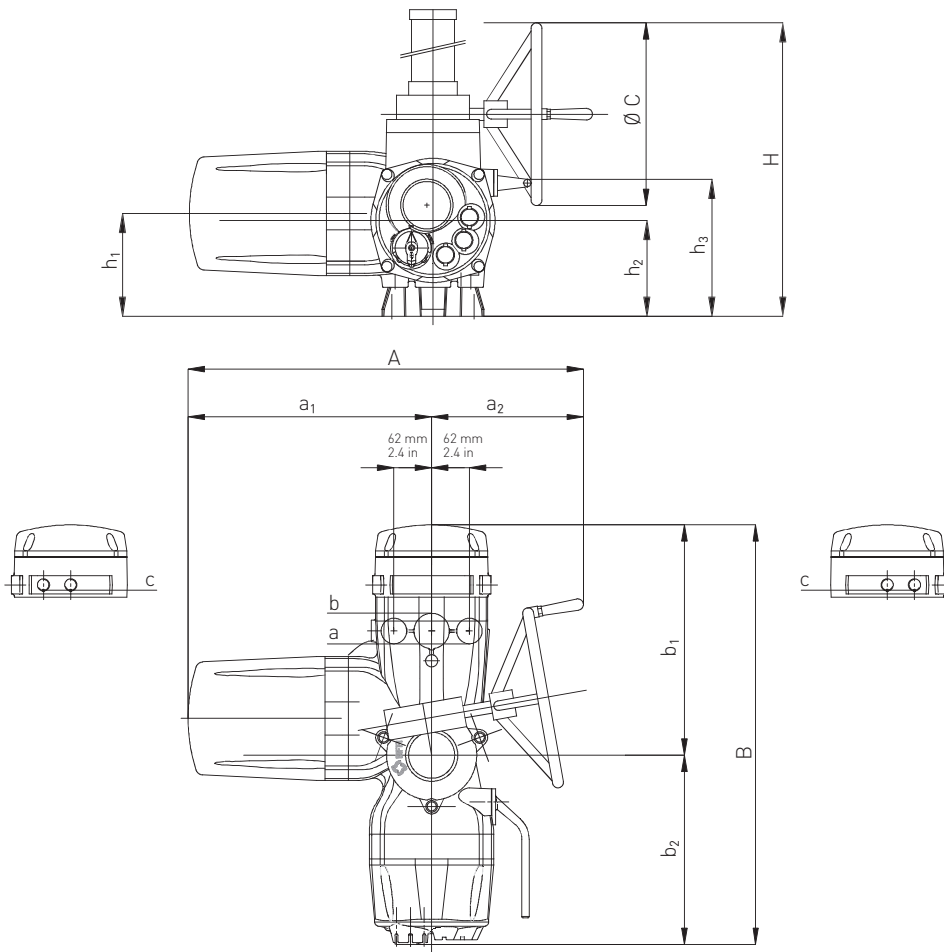

Standard cable entries:  
 a = 2 x 1" NPT  
 b = 1 x 1½" NPT  
 c = 4 x ½" NPT  
 Metric options available on request

### ICON 2000 SERIES WITH REDUCED MANUAL OVERRIDE AND DETACHABLE PROFIBUS - METRIC (mm / kg)

Model	A	a <sub>1</sub>	a <sub>2</sub>	B	b <sub>1</sub>	b <sub>2</sub>	Ø C	H	h <sub>1</sub>	h <sub>2</sub>	h <sub>3</sub>	Manual override	
												R	Mass (kg)
ICON-030	648	399	249	687	379	308	300	500	175	175	269	10 / 1	84
ICON-040	723	455	268	752	384	368	400	574	196	191	291	13 / 1	100
ICON-050	799	528	271	816	429	387	500	685	223	218	336	17 / 1	124



# ICON 2000 ELECTRIC ACTUATORS

## OVERALL DIMENSIONS - STANDARD WITHOUT COUPLING AND INSERT BUSH

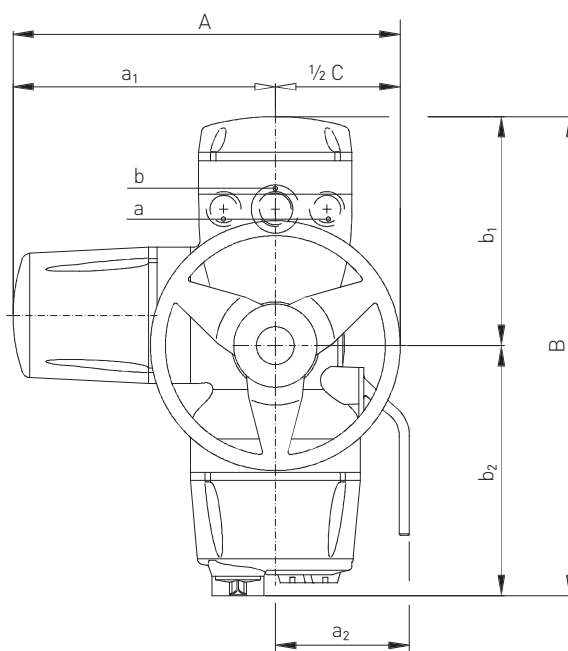
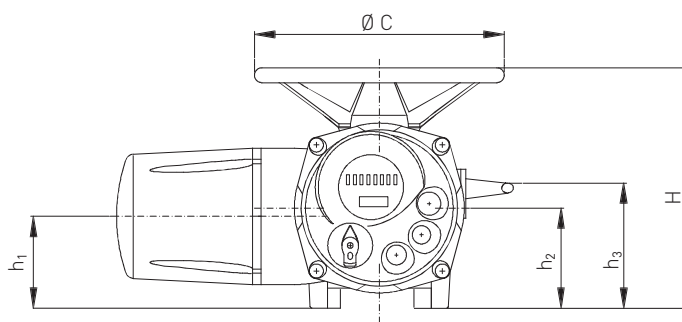

Standard cable entries:  
 a = 2 x 1" NPT  
 b = 1 x 1½" NPT  
 Metric options available on request

### ICON 2000 SERIES WITHOUT COUPLING AND INSERT BUSH - METRIC (mm / kg)

Model	A	a <sub>1</sub>	a <sub>2</sub>	B	b <sub>1</sub>	b <sub>2</sub>	Ø C	H	h <sub>1</sub>	h <sub>2</sub>	h <sub>3</sub>	Mass (kg)
ICON-010	484	325	159	561	273	288	300	290	100	110	168	30
ICON-020	597	347	159	579	283	296	500	323	110	110	189	42
ICON-030	699	399	159	621	313	308	600	365	110	110	205	65

# ICON 2000 ELECTRIC ACTUATORS

## OUTPUT DRIVE TYPE A DIMENSIONS

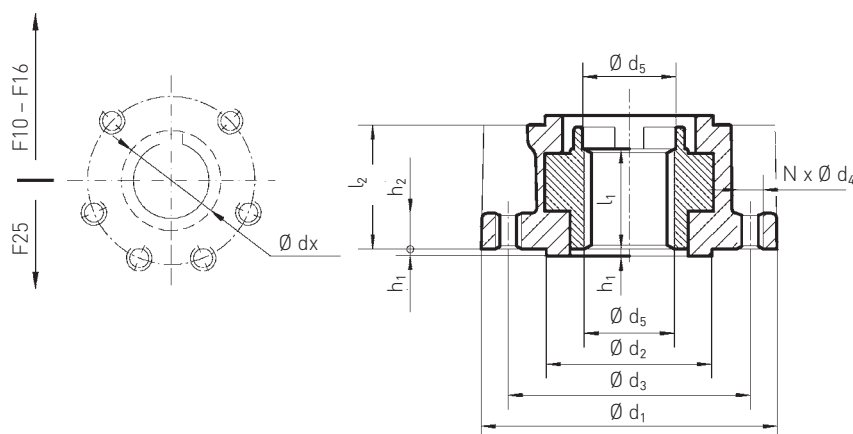

### ICON 2000 COUPLINGS TYPE A - METRIC (mm)

Model	010	020	030	040	050
ISO 5210	F10	F14	F14	F16	F25
$F_{nom}$ [kN]	40	100	150	180	300
$F_{max}$ [kN]	60	150	225	270	450
$\varnothing d_1$	125	175	175	210	300
$\varnothing d_2 f_8$	70	100	100	130	200
$\varnothing d_3$	102	140	140	165	254
$\varnothing d_4$	M10	M16	M16	M20	M16
$\varnothing d_5$	33	46	62	68	78
$\varnothing d_6 max$	32	45	60.5	65	77
$\varnothing d_6$ not machined *	18 *	19	26	30	35
$\varnothing d_x max$	32	45	60.5	65	77
$l_1$	40	55	70	75	95
$l_2$	51	68	84	94	120
$h_1$	3	4	4	5	5
$h_2$	15	24	24	30	24
N	4	4	4	4	8
Mass [kg]	2	8	8	15	28

### NOTES TO COUPLINGS TYPE A

- $\varnothing d_6$  = Max threaded stem acceptance
- $\varnothing d_x$  = The maximum accepted diameter described by the key
- $F_{nom}$  = The max thrust applicable to the ICON 2000 block type 'A' in dynamic conditions with torque control set at 100%
- $F_{max}$  = The max thrust applicable to the ICON 2000 block type 'A' in static conditions with manual override or with motor in stall torque
- \* = Not applicable in case of insert bush blind

# ICON 2000 ELECTRIC ACTUATORS

## OUTPUT DRIVE TYPE B1/B2 DIMENSIONS

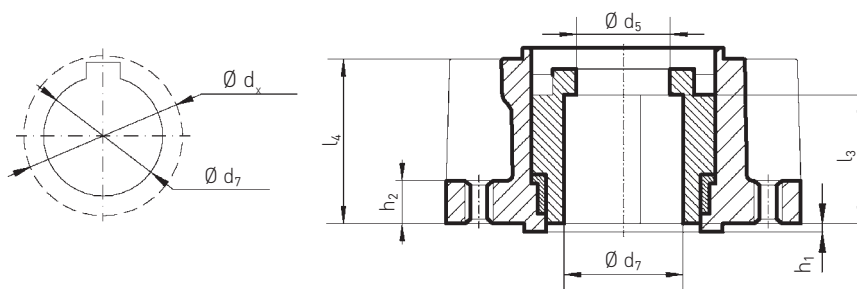

Flange dimensions as per type A

### ICON 2000 COUPLINGS TYPE B1/B2 - METRIC (mm)

Model	010	020	030	040	050
ISO 5210	F10	F14	F14	F16	F25
$\varnothing d_5$	33	46	62	68	78
B1 $\varnothing d_7$ H9	42	60	60	80	100
B2 $\varnothing d_7$ max	42	60	60	80	100
$\varnothing d_x$ max	50	71	71	94	116
$l_3$	45	65	65	80	110
$l_4$	56	85	84	105	155
Mass [kg]	2	7	7	14	26

### NOTES TO COUPLINGS TYPE B1/B2

- $\varnothing d_7$  = With standard keyway according to ISO 773
- $\varnothing d_x$  = The maximum accepted diameter described by the key

# ICON 2000 ELECTRIC ACTUATORS

## OUTPUT DRIVE TYPE ASC SPRING COMPENSATED DIMENSIONS

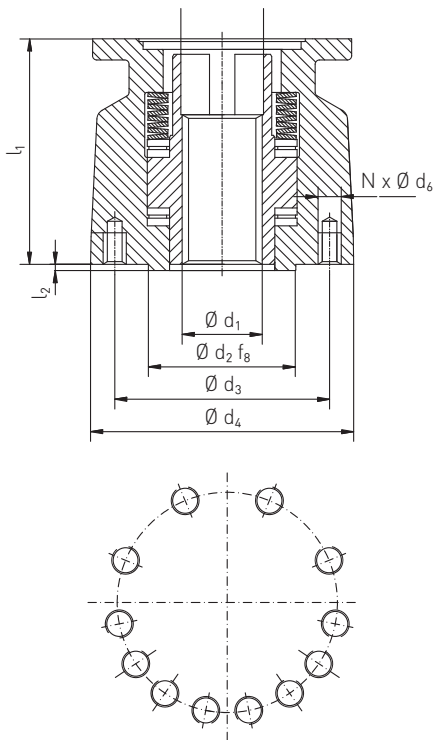

### ICON 2000 COUPLINGS TYPE ASC - METRIC (mm)

Model	010	020	030	040	050
ISO 5210	F10	F14	F14	F16	F25
$F_{nom}$ [kN]	40	100	150	180	300
$F_{max}$ [kN]	60	150	225	270	450
$\varnothing d_1$	32	45	60.5	65	77
$\varnothing d_2 f_8$	70	100	100	130	200
$\varnothing d_3$	102	140	140	165	254
$\varnothing d_4$	150	175	214	269	300
$\varnothing d_5$	33	46	62	68	78
$\varnothing d_6$	M10	M16	M16	M20	M16
$l_1$	155	211.5	260	253	317
$l_2$	3	3	4	4	5
N	4	4	4	4	8

### NOTES

1. Type ASC is a block having the capability to transmit both a torque and a thrust and that includes a spring system to absorb either valve stem elongations due to temperature variations or the motor energy when high speed actuators are used.
2. The need of the ASC thrust block must be defined according to effective working conditions of valve/ actuator assembly.
3. Minimum threaded valve stem protrusion : 1,10/1
4.  $F_{nom}$ : is the initial spring load acting on the stem nut.  
 $F_{max}$ : is the maximum load acting on the stem nut with spring completely compressed.
5. Lower values for F0 are available on request

# ICON 2000 ELECTRIC ACTUATORS

## OUTPUT DRIVE TYPE B3/B4 DIMENSIONS

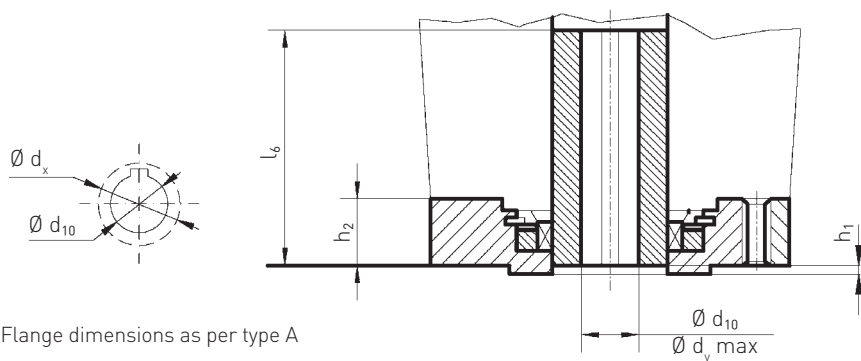

### ICON 2000 COUPLINGS TYPE B3/B4 - METRIC (mm)

Model	010	020	030	040	050
ISO 5210	F10	F14	F14	F16	F25
B3Ø d <sub>10</sub> H9	20	30	30	40	50
B4Ø d <sub>y</sub> max	22	32	46	50	58
Ø d <sub>x</sub>	26	40	55	60	68
l <sub>6</sub>	100	120	130	150	180
Mass (kg)	1	6	6	12	20

### NOTES TO COUPLINGS TYPE B3/B4

Flange dimensions as per type A

Ø d<sub>10</sub> = With standard keyway according to ISO 773

Ø d<sub>x</sub> = The maximum accepted diameter described by the key

# ICON 2000 ELECTRIC ACTUATORS

## BLOCK AND TERMINALS DIAGRAM

On/Off or Inching service  
 Default relay configuration  
 (may be modified - see instruction manual)

- AS1 = Open limit / make
- AS2 = Close limit / make
- AS3 = Selec.REMOTE pos. make
- AS4 = Over-torque / break
- AS5 = Motor running / make
- AS6 = Position <10% / make
- AS7 = ESD / make
- AS8 = Motor over temperature

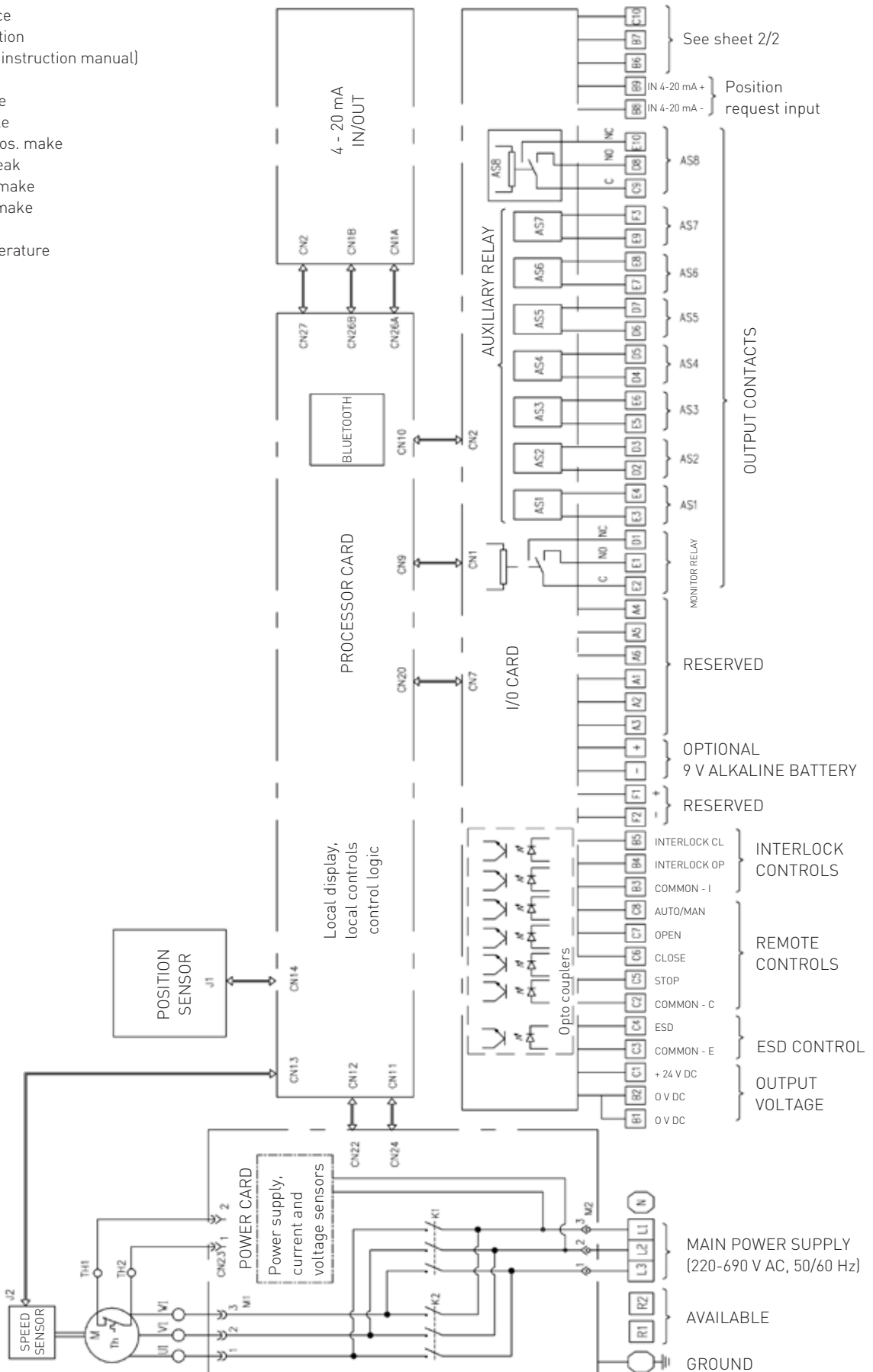

# ICON 2000 ELECTRIC ACTUATORS

## BLOCK AND TERMINALS DIAGRAM

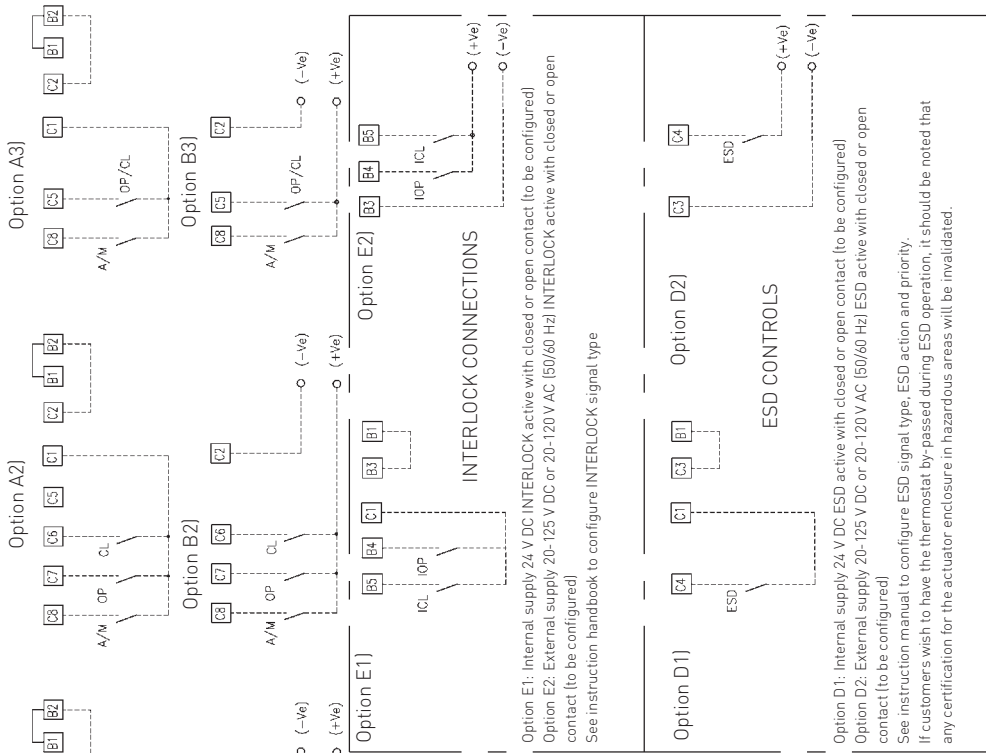

**Option E1:** Internal supply 24 V DC INTERLOCK active with closed or open contact (to be configured)  
**Option E2:** External supply 20-125 V DC or 20-120 V AC (50/60 Hz) INTERLOCK active with closed or open contact (to be configured)  
 See instruction handbook to configure INTERLOCK signal type

**Option D1:** Internal supply 24 V DC ESD active with closed or open contact (to be configured)  
**Option D2:** External supply 20-125 V DC or 20-120 V AC (50/60 Hz) ESD active with closed or open contact (to be configured)  
 See instruction manual to configure ESD signal type. ESD action and priority.  
 If customers wish to have the thermostat by-passed during ESD operation, it should be noted that any certification for the actuator enclosure in hazardous areas will be invalidated.

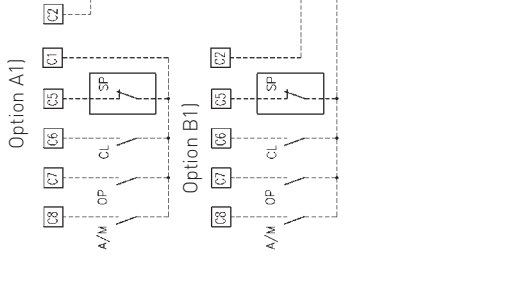

See instruction handbook to configure options A1, A2, A3, B1, B2, B3.  
 For 4-20mA connections see MAN 618/5, optional modules PSM1 and APTM1.  
 Remote STOP control SP can be configured to perform the STOP action when the contact is open (break) or closed (make).

KEY	
M	= Three phase motor
Th	= Motor thermostat
OP	= OPEN control
CL	= CLOSE control
SP	= STOP control
K1	= Opening/Closing contactor
K2	= Opening/Closing contactor

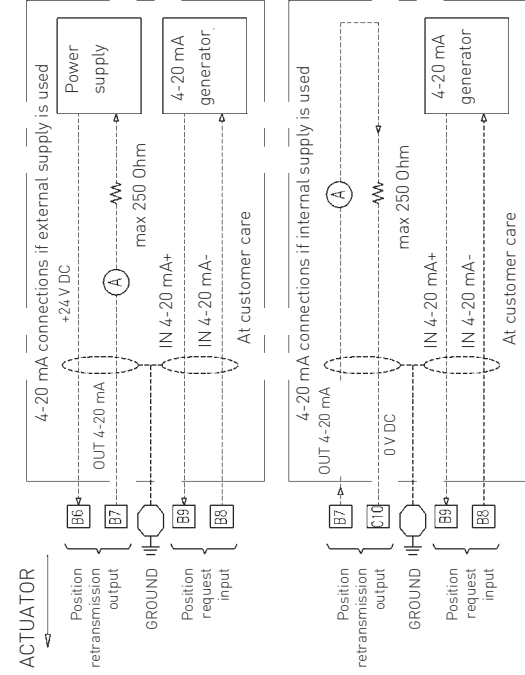

**Notes:**

- 1) B1-B2 : Internally linked
- 2) C1 : +24 V DC not regulated, max 4 W
- 3) Control signal levels:  
 Minimum 'ON' >20 V DC or 20 V AC (50/60 Hz)  
 Maximum 'ON' <125 V DC or 120 V AC (50/60 Hz)  
 Maximum 'OFF' <3 V DC or AC  
 Minimum signal duration >500 ms  
 Total current drawn for remote controls <25 mA  
 Total current drawn for ESD controls <15 mA
- 4) Monitor relay:  
 Voltage free, change-over contact- max voltage 250 V AC or 30 V DC - max current 5 A/min voltage 5 V DC - min. current 10 mA  
 See instruction manual to view or configure the switching conditions of relay  
 -E2/D1 contact is closed when the configured condition occurs
- 5) AS1, AS2, AS3, AS4, AS5, AS6, AS7: Voltage- free contact. Max voltage 250 V AC or 30 V DC - max current 5 A / min voltage 5 V DC - min current 10 mA  
 Contact can be configured to make or break on condition. See instruction manual to view or configure switching conditions of relays.
- 6) AS8 : Voltage free, change-over contact- max voltage 250 V AC or 30 V DC - max current 5 A/min, voltage 5 V DC - min. current 10 mA  
 See instruction manual to view or configure the switching conditions of relay  
 -C9/D8 contact is closed when the configured condition occurs
- 7) A1, A2, A3 : Internal supply 24 V DC
- 8) B1, B2, B3 : External supply 20-125 V DC or 20-120 V AC (50/60 Hz)
- 9) Controls mode :  
 Option A1/B1 : 4 wires latched (SP configuration = BREAK)  
 Option A2/B2 : 3 wires push to run  
 : 3 wires latched with instant reverse  
 Option A3/B3 : 2 wires open contact opens  
 : 2 wires open contact closes
- 10) A/M Open: Remote/Auto Actuator control by 4-20 mA input signal  
 A/M Closed: Remote/Man Actuator control by remote push-buttons

# ICON 2000 ELECTRIC ACTUATORS

## SPUR GEAR REDUCER TYPE SGR

For application on valves when a multiturn actuator is required and torque exceeds 1440 Nm. The spur gear reducer and its thrust block are designed for the most severe duties.



### SGR MULTITURN ACTUATOR PERFORMANCE

Model SGR	Nom. torque (100%) (Nm)	Min. torque (40%) (Nm)	RPM** (50 Hz)	RPM** (60 Hz)
SGR-160-030/1750-**	1750	700	26	31
SGR-160-030/2150-**	2150	860	21	26
SGR-160-030/2880-**	2880	1152	8	10
SGR-160-030/2880-**	2880	1152	16	19
SGR-250-030/3600-**	3600	1440	12	15
SGR-250-040/3600-**	3600	1440	24	29
SGR-250-030/4800-**	4800	1920	5	6
SGR-250-030/4800-**	4800	1920	9	11
SGR-250-040/4800-**	4800	1920	18	22
SGR-250-050/4800-**	4800	1920	36	43
SGR-400-030/7500-**	7500	3000	6	7
SGR-400-040/7500-**	7500	3000	12	14
SGR-400-050/7500-**	7500	3000	24	29
SGR-400-040/9600-**	9600	3840	5	6
SGR-400-040/9600-**	9600	3840	9	11
SGR-400-050/9600-**	9600	3840	18	22
SGR-640-050/9600-**	9600	3840	18	22
SGR-640-040/15000-**	15000	6000	6	7
SGR-640-050/16000-**	16000	6400	11	13
SGR-640-050/19200-**	19200	7680	5	6
SGR-640-050/19200-**	19200	7680	9	11
SGR-1000-050/22000-**	22000	8800	8	9
SGR-1000-050/28000-**	28000	11200	6	7
SGR-1000-050/37000-**	37000	14800	2	3
SGR-1000-050/37000-**	37000	14800	5	6
SGR-1600-050/40000-**	40000	16000	4	5
SGR-1600-050/48000-**	48000	19200	3	4
SGR-1600-050/57000-**	57000	22800	3	4

### NOTES

1. The \*\* are to be replaced by operating time value at selected frequency (50 or 60 Hz)
2. Nominal output torque settable from 40% (minimum torque) to 100% of indicated value
3. Theoretic max output torque. The actual max output torque is a function of speed and motor power supply and may vary from 1.3 to 2 times nominal output torque
4. The performance table above relates to ON/OFF S2-15' or INCHING S4-25%-60 starts/hour duties (IEC34-1)



**ICON 2000 ELECTRIC ACTUATORS**  
 SPUR GEAR REDUCER TYPE SGR - COUPLING DIMENSIONS

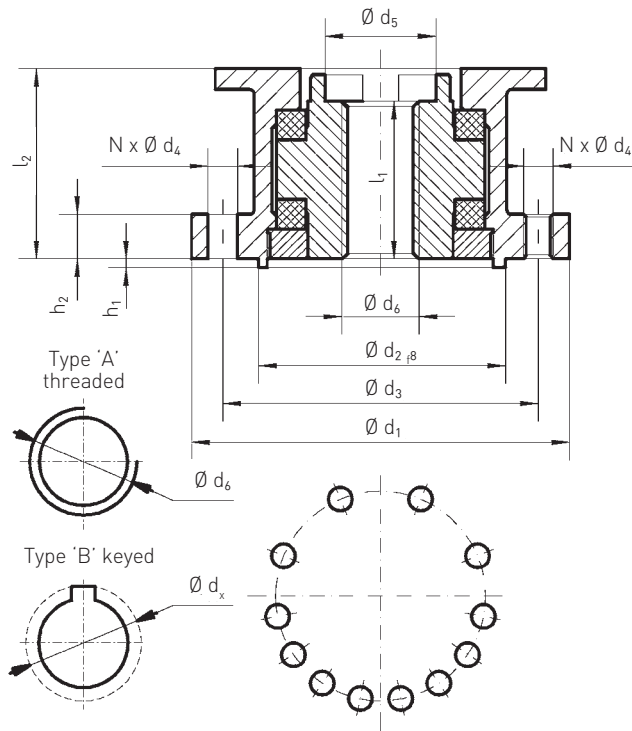

**ICON 2000 SERIES SGR - METRIC (mm / kg)**

Model	SGR 160	SGR 250	SGR 400	SGR 640	SGR 1000	SGR 1600
ISO 5210	F30	F35	F35	---	---	---
$F_{nom}$ (kN)	440	700	1200	2250	3200	4500
$F_{max}$ (kN)	660	1050	1800	3375	4800	6750
$\varnothing d_1$	350	415	415	475	500	620
$\varnothing d_{2,8}$	230	260	260	300	330	400
$\varnothing d_3$	298	356	356	406	425	520
$\varnothing d_4$	22	33	33	39	M36	M45
$\varnothing d_5$	78	97	109	130	156	188
$\varnothing d_6$ max ( $d_x$ )	77	96	108	127	153	180
$\varnothing d_6$ min	51	55	60	75	90	95
$l_1$	110	144	178	216	252	307
$l_2$	134	172	201	250	290	354
$h_1$	5	5	5	8	8	8
$h_2$	30	40	45	45	50	58
N	8	8	8	16	16	16
Mass (kg)	48	75	105	150	195	250

**NOTES TO COUPLINGS TYPE A**

- Type 'A' = The block having the capability to transmit both a torque and a thrust
- $\varnothing d_x$  = The maximum accepted diameter described by the key
- $l_1 \times 1.10$  = Minimum threaded valve stem protrusion
- $F_{nom}$  = The max thrust applicable to the SGR block type 'A' in dynamic conditions with torque control set at 100%
- $F_{max}$  = The max thrust applicable to the SGR block type 'A' in static conditions with manual override or with motor in stall torque

# ICON 2000 ELECTRIC ACTUATORS

## SPUR GEAR REDUCER DIMENSIONS - STANDARD MANUAL OVERRIDE

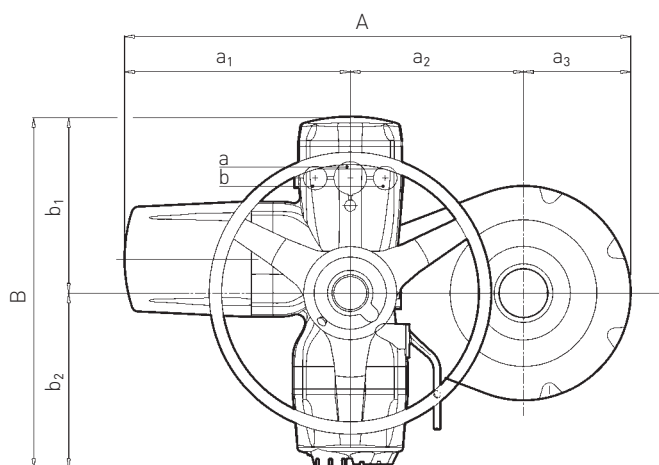
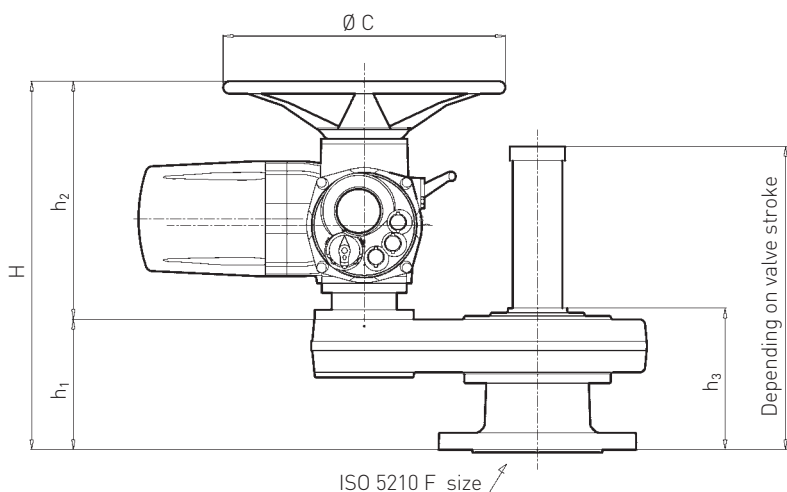

Standard cable entries:  
 a = 2 x 1" NPT  
 b = 1 x 1½" NPT

### ICON 2000 SERIES SGR OVERALL DIMENSIONS - METRIC (mm / kg)

Model	A	a <sub>1</sub>	a <sub>2</sub>	a <sub>3</sub>	B	b <sub>1</sub>	b <sub>2</sub>	ØC	F	H	h <sub>1</sub>	h <sub>2</sub>	h <sub>3</sub>	Mass (kg)
SGR-160-030	859	399	270	190	625	313	312	400	F30	617	231	380	251	127
SGR-250-030	927	399	319	227	625	313	312	500	F35	684	315	380	345	154
SGR-250-040	983	445	319	227	690	318	372	500	F35	724	280	420	310	170
SGR-250-050	1036	508	319	227	775	363	392	500	F35	684	280	380	310	194
SGR-400-030	980	399	373	208	625	313	312	500	F35	736	356	380	383	232
SGR-400-040	1036	455	373	208	690	318	372	500	F35	776	356	420	383	248
SGR-400-050	1089	508	373	208	775	363	392	500	F35	866	356	510	383	272
SGR-640-040	1098	455	405	237	690	318	372	600	spec.	838	418	420	460	288
SGR-640-050	1151	508	405	238	755	363	392	600	spec.	928	418	510	460	312
SGR-1000-050	1264	508	456	300	755	363	392	600	spec.	968	458	510	500	417
SGR-1600-050	1560	508	602	450	755	363	392	600	spec.	1040	522	510	564	752

**ICON 2000 ELECTRIC ACTUATORS**  
 SPUR GEAR REDUCER DIMENSIONS - REDUCED MANUAL OVERRIDE

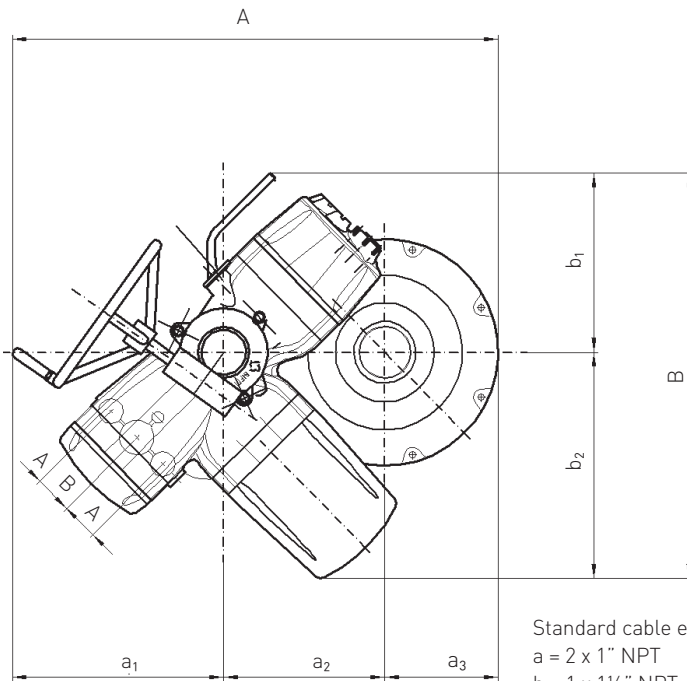
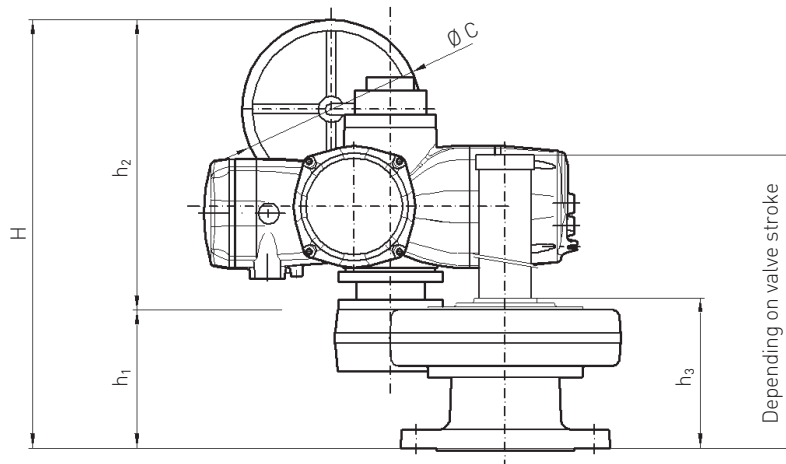

**ICON 2000 SERIES SGR OVERALL DIMENSIONS WITH REDUCED MANUAL OVERRIDE - METRIC (mm / kg)**

Model	A	a <sub>1</sub>	a <sub>2</sub>	a <sub>3</sub>	B	b <sub>1</sub>	b <sub>2</sub>	Ø C	H	h <sub>1</sub>	h <sub>2</sub>	h <sub>3</sub>	Mass (kg)
SGR-160-030	814	354	270	190	679	300	379	300	717	231	486	251	135
SGR-250-030	880	354	319	227	678	302	376	300	748	315	448	345	162
SGR-250-040	942	416	319	227	742	310	432	400	828	280	528	310	178
SGR-250-050	1012	484	319	227	809	334	475	500	977	280	677	310	202
SGR-400-030	934	354	373	208	678	302	376	300	817	356	461	383	240
SGR-400-040	995	415	373	208	741	311	430	400	884	356	528	383	256
SGR-400-050	1064	484	373	208	809	334	475	500	1033	356	677	383	280
SGR-640-040	1057	415	405	238	743	311	432	400	947	418	528	460	296
SGR-640-050	1124	482	405	238	807	335	472	500	1091	418	673	460	320
SGR-1000-050	1240	484	456	300	809	334	475	500	1132	458	674	500	425
SGR-1600-050	1535	483	602	450	808	334	474	500	1196	522	674	564	760

# ICON 2000 ELECTRIC ACTUATORS

## WGR - WORM GEAR REDUCERS FOR QUARTER TURN VALVES

For application on any type of quarter turn valves (ball, butterfly, plug...).  
The worm gear is designed to meet AWWA C-540 and other major standards.



### ICON 2000 SERIES WGR ACTUATOR PERFORMANCE WITH THREE PHASE MOTOR

Model WGR	Nom. torque (100%) (Nm)	Min. torque (40%) (Nm)	Max. torque (Nm)	Op. time/90°** (secs at 50 Hz)	Op. time/90°** (secs at 60 Hz)
WGR-100/330-**-	330	132	500	63	52
WGR-100/330-**-	330	132	500	42	35
WGR-100/330-**-	330	132	500	31	26
WGR-100/330-**-	330	132	500	21	17
WGR-100/330-**-	330	132	500	16	13
WGR-100/330-**-	330	132	500	10	9
WGR-100-010/1000-**-	1000	400	1500	63	52
WGR-100-010/1000-**-	1000	400	1500	42	35
WGR-100-010/1000-**-	1000	400	1500	31	26
WGR-100-010/1000-**-	1000	400	1500	21	17
WGR-100-010/1000-**-	1000	400	1500	16	13
WGR-100-010/1000-**-	1000	400	1500	10	9
WGR-200-010/2000-**-	2000	800	3000	125	104
WGR-200-010/2000-**-	2000	800	3000	83	69
WGR-200-010/2000-**-	2000	800	3000	63	52
WGR-200-010/2000-**-	2000	800	3000	42	35
WGR-200-010/2000-**-	2000	800	3000	31	26
WGR-200-010/2000-**-	2000	800	3000	21	17
WGR-200-010/2000-**-	2000	800	3000	10	9
WGR-400-010/4000-**-	4000	1600	6000	155	118
WGR-400-010/4000-**-	4000	1600	6000	103	78
WGR-400-010/4000-**-	4000	1600	6000	78	59
WGR-400-010/4000-**-	4000	1600	6000	52	39
WGR-400-010/4000-**-	4000	1600	6000	39	29
WGR-400-010/4000-**-	4000	1600	6000	26	20
WGR-400-010/4000-**-	4000	1600	6000	13	10
WGR-800-020/8000-**-	8000	3200	12000	229	196
WGR-800-020/8000-**-	8000	3200	12000	153	125
WGR-800-020/8000-**-	8000	3200	12000	114	95
WGR-800-020/8000-**-	8000	3200	12000	76	64
WGR-800-020/8000-**-	8000	3200	12000	57	47
WGR-800-020/8000-**-	8000	3200	12000	38	32
WGR-800-020/8000-**-	8000	3200	12000	19	16

#### NOTES

1. The \*\* are to be replaced by operating time value at selected frequency (50 or 60 Hz)
2. Nominal output torque settable from 40% (minimum torque) to 100% of indicated value
3. Theoretic max output torque. The actual max output torque is a function of speed and motor power supply and may vary from 1.3 to 2 times nominal output torque
4. The performance table above relates to ON/OFF S2-15' or INCHING S4-25%-60 starts/hour duties (IEC34-1)

# ICON 2000 ELECTRIC ACTUATORS

## WGR - WORM GEAR REDUCERS FOR QUARTER TURN VALVES

### ICON 2000 SERIES WGR ACTUATOR PERFORMANCE WITH THREE PHASE MOTOR

Model WGR	Nom. torque (100%) (Nm)	Min. torque (40%) (Nm)	Max. torque (Nm)	Op. time/90°** (secs at 50 Hz)	Op. time/90°** (secs at 60 Hz)
WGR-1600-020/16000-**	16000	6400	24000	466	389
WGR-1600-020/16000-**	16000	6400	24000	311	259
WGR-1600-020/16000-**	16000	6400	24000	233	194
WGR-1600-020/16000-**	16000	6400	24000	155	130
WGR-1600-020/16000-**	16000	6400	24000	117	97
WGR-1600-020/16000-**	16000	6400	24000	78	65
WGR-1600-020/16000-**	16000	6400	24000	39	32
WGR-3200-020/32000-**	32000	12800	48000	623	519
WGR-3200-020/32000-**	32000	12800	48000	467	389
WGR-3200-020/32000-**	32000	12800	48000	311	259
WGR-3200-020/32000-**	32000	12800	48000	233	195
WGR-3200-020/32000-**	32000	12800	48000	156	130
WGR-3200-020/32000-**	32000	12800	48000	78	65
WGR-3200-030/32000-**	32000	12800	48000	42	35
WGR-6300-020/63000-**	63000	25200	94500	700	583
WGR-6300-020/63000-**	63000	25200	94500	525	438
WGR-6300-020/63000-**	63000	25200	94500	350	292
WGR-6300-020/63000-**	63000	25200	94500	175	146
WGR-6300-030/63000-**	63000	25200	94500	96	80
WGR-6300-040/63000-**	63000	25200	94500	39	33

#### NOTES

1. The \*\* are to be replaced by operating time value at selected frequency (50 or 60 Hz)
2. Nominal output torque settable from 40% (minimum torque) to 100% of indicated value
3. Theoretic max output torque. The actual max output torque is a function of speed and motor power supply and may vary from 1.3 to 2 times nominal output torque
4. The performance table above relates to ON/OFF S2-15' or INCHING S4-25%-60 starts/hour duties (IEC34-1)

# ICON 2000 ELECTRIC ACTUATORS

## WORM GEAR REDUCER TYPE WGR DRIVE SLEEVE DIMENSIONS

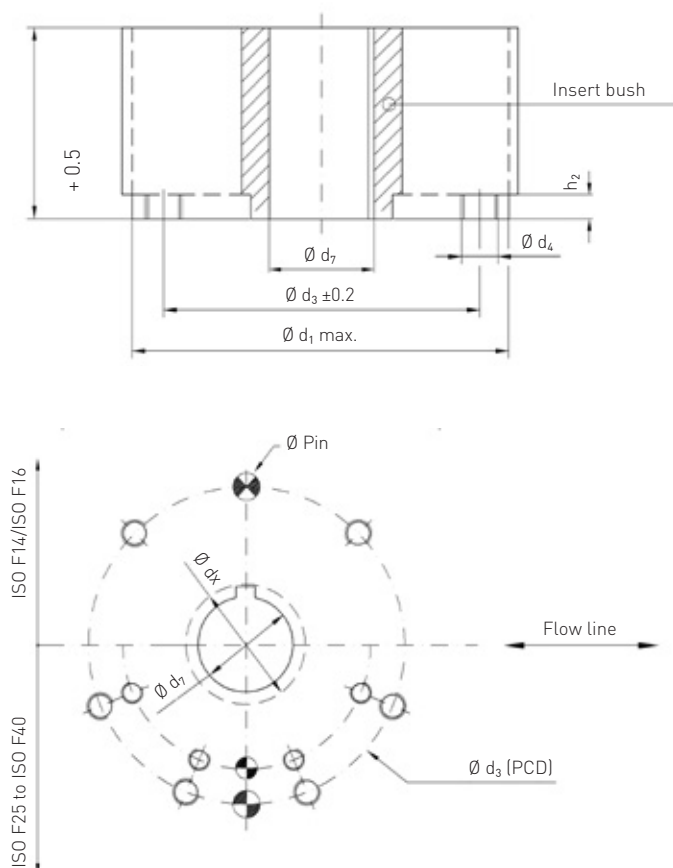

### ICON 2000 SERIES WGR - METRIC (mm)

Model	ISO 5211	Ø d <sub>1</sub>	Ø d <sub>3</sub>	Ø d <sub>4</sub>	N°	H max stem		Ø Pin	d <sub>7</sub> max stem acceptance insert bush	
						height	h <sub>2</sub>		Ø d <sub>7</sub>	Ø d <sub>4</sub>
WGR-100	F14	175	140	M16	4	100	16	16	42	51
WGR-200	F16	210	165	M20	4	105	20	16	65	76
WGR-400	F16	210	165	M20	4	105	20	16	65	76
WGR-800	F25	300	254	M16	8	115	20	20	90	104
WGR-800	F30	350	298	M20	8	115	20	20	90	104
WGR-1600	F25	300	254	M16	8	140	24	20	103	120
WGR-1600	F30	350	298	M20	8	140	30	20	103	120
WGR-3200	F30	350	298	M20	8	165	30	20	120	139
WGR-3200	F35	415	356	M30	8	165	30	20	120	139
WGR-6300	F40	475	406	M36	8	250	35	30	170	194

### NOTES

1. Insert bush supplied by Biffi with unmachined bore. Machining of bore upon request
2. Fixing bolts or rods supplied by Biffi only on request, minimum material class required 8.8 UNI37409, ASTM A320-L7
3. Any other coupling can be supplied on request
4. Flanges for models WGR-800, 1600 and 3200 have double PCD

# ICON 2000 ELECTRIC ACTUATORS

## WORM GEAR REDUCER TYPE WGR OVERALL DIMENSIONS

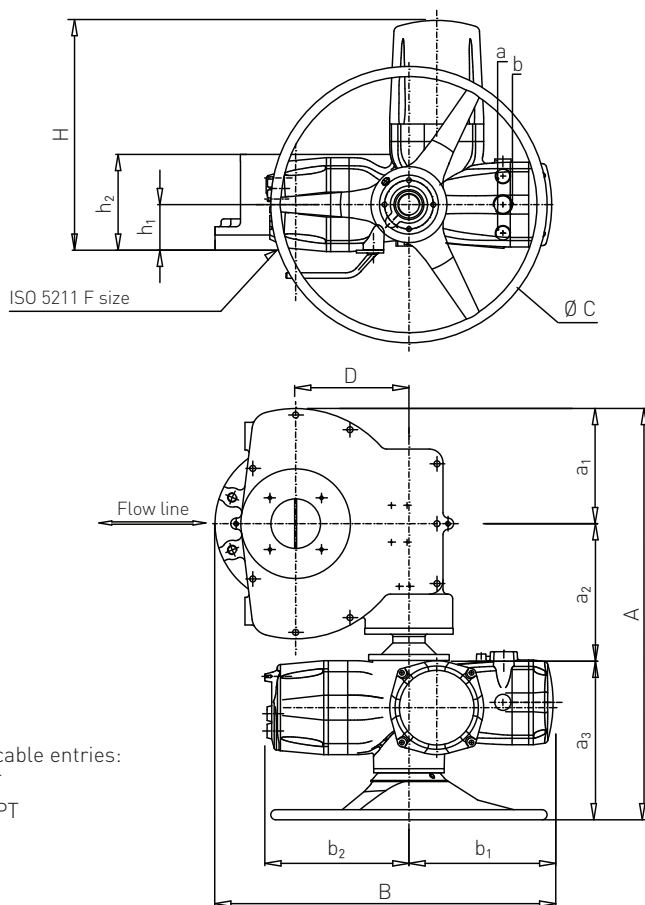

Standard cable entries:  
 $a = 1''$  NPT  
 $b = 1\frac{1}{2}''$  NPT

### ICON 2000 SERIES WGR OVERALL DIMENSIONS - METRIC (mm / kg)

Model	A	$a_1$	$a_2$	$a_3$	B	$b_1$	$b_2$	$\varnothing C$	D	F	H	$h_1$	$h_2$	Mass (kg)
WGR-100-010	499	90	137	272	564	273	291	300	86	F14	387	62	115	39
WGR-200-010	540	121	147	272	564	273	291	300	119	F16	378	53	131	42
WGR-400-010	657	121	264	272	564	273	291	300	119	F16	378	53	131	60
WGR-800-020	776	175	295	306	588	283	299	500	130	F25/F30	415	68	151	75
WGR-1600-020	810	175	329	306	620	283	299	500	162	F25/F30	444	97	191	106
WGR-3200-020	852	250	296	306	704	283	299	500	246	F30/F35	453	106	213	166
WGR-3200-030	893	250	296	347	734	313	311	600	246	F30/F35	506	106	213	174
WGR-6300-020	1012	306	400	306	823	283	299	500	301	F40	482	135	285	509
WGR-6300-030	1053	306	400	347	851	313	311	600	301	F40	535	135	285	517
WGR-6300-040	1090	306	400	384	858	318	318	720	301	F40	590	135	285	527

# ICON 2000 ELECTRIC ACTUATORS

## WGS WORM GEAR REDUCER

The standard worm gear WGS is suitable for application on any type of quarter turn valves (ball, butterfly, plug...).

### ICON 2000 SERIES WGS ACTUATOR PERFORMANCE WITH THREE PHASE MOTOR

Model <sup>[1]</sup>	Cnom <sup>[2]</sup> (100%) (Nm)	"Cmax <sup>[3]</sup> (Nm)	Time/90° (secs) at 50Hz <sup>[7]</sup>	Time/90° (secs) at 60Hz <sup>[7]</sup>	Ratio
WGS-100-010/330-**	330	495	50	43	40:1
WGS-100-010/330-**	330	495	33	27	40:1
WGS-100-010/330-**	330	495	25	21	40:1
WGS-100-010/330-**	330	495	17	14	40:1
WGS-100-010/330-**	330	495	13	10	40:1
WGS-100-010/330-**	330	495	8	7	40:1
WGS-100-010/330-**	330	495	4	3	40:1
WGS-120-010/1000-**	1017	1526	53	45	42:1
WGS-120-010/1000-**	1017	1526	35	29	42:1
WGS-120-010/1000-**	1017	1526	26	22	42:1
WGS-120-010/1000-**	1017	1526	18	15	42:1
WGS-120-010/1000-**	1017	1526	13	11	42:1
WGS-120-010/1000-**	1017	1526	9	7	42:1
WGS-120-010/1000-**	1017	1526	4	4	42:1
WGS-140-010/1450-**	1458	2187	75	64	60:1
WGS-140-010/1450-**	1458	2187	50	41	60:1
WGS-140-010/1450-**	1458	2187	38	31	60:1
WGS-140-010/1450-**	1458	2187	25	21	60:1
WGS-140-010/1450-**	1458	2187	19	16	60:1
WGS-140-010/1450-**	1458	2187	13	10	60:1
WGS-140-010/1450-**	1458	2187	6	5	60:1
WGS-150-010/1840-**	1845	2768	85	73	68:1
WGS-150-010/1840-**	1845	2768	57	46	68:1
WGS-150-010/1840-**	1845	2768	43	35	68:1
WGS-150-010/1840-**	1845	2768	28	24	68:1
WGS-150-010/1840-**	1845	2768	21	18	68:1
WGS-150-010/1840-**	1845	2768	14	12	68:1
WGS-150-010/1840-**	1845	2768	7	6	68:1
WGS-160-010/2300-**	2385	3578	73	94	88:1
WGS-160-010/2300-**	2385	3578	55	60	88:1
WGS-160-010/2300-**	2385	3578	37	46	88:1
WGS-160-010/2300-**	2385	3578	28	31	88:1
WGS-160-010/2300-**	2385	3578	28	23	88:1
WGS-160-010/2300-**	2385	3578	18	15	88:1
WGS-160-010/2300-**	2385	3578	9	8	88:1
WGS-200-010/5100-**	5137	7706	229	196	183:1
WGS-200-010/5100-**	5137	7706	153	125	183:1
WGS-200-010/5100-**	5137	7706	114	95	183:1
WGS-200-010/5100-**	5137	7706	76	64	183:1
WGS-200-010/5100-**	5137	7706	57	47	183:1
WGS-200-010/5100-**	5137	7706	38	32	183:1
WGS-200-010/5100-**	5137	7706	19	16	183:1
WGS-302-010/6500-**	6535	9803	285	245	228,3:1
WGS-302-010/6500-**	6535	9803	190	156	228,3:1
WGS-302-010/6500-**	6535	9803	143	118	228,3:1
WGS-302-010/6500-**	6535	9803	95	80	228,3:1
WGS-302-010/6500-**	6535	9803	71	59	228,3:1
WGS-302-010/6500-**	6535	9803	48	40	228,3:1
WGS-302-010/6500-**	6535	9803	24	20	228,3:1



- (1) Complete the Code Model by replacing \*\* with the stroking time (sec per 90°) at the selected frequency.
- (2) Nominal output torque to be set between the 100% value reported in the table and the minimum value of 40%.
- (3) Theoretical max output torque. Based on motor power supply and output speed, the Max torque value may be from 1,4 to 2 times the Nominal Torque value.
- (4) The performances are relevant to Service ON-OFF S2-15' (CEI 2-3) or to Service Inching S4-25%-60 starts/hour (CEI 2-3).
- (5) Three-phase power supply from 208V to 690V at frequency 50/60Hz.
- (6) Ambient temperature from -40°C to +85°C.
- (7) Please consider a tolerance of +/- 5% on the reported stroking times.



# ICON 2000 ELECTRIC ACTUATORS

## WGS WORM GEAR REDUCER

### ICON 2000 SERIES WGS ACTUATOR PERFORMANCE WITH THREE PHASE MOTOR (Continued)

Model <sup>[1]</sup>	Cnom <sup>[2]</sup>	"Cmax <sup>[3]</sup>	Time/90°	Time/90°	Ratio
WGS"	(100%) (Nm)	(Nm)	(secs) at 50Hz <sup>[7]</sup>	(secs) at 60Hz <sup>[7]</sup>	
WGS-300-010/8800-**	8848	13272	386	331	309:1
WGS-300-010/8800-**	8848	13272	258	211	309:1
WGS-300-010/8800-**	8848	13272	193	160	309:1
WGS-300-010/8800-**	8848	13272	129	108	309:1
WGS-300-010/8800-**	8848	13272	97	80	309:1
WGS-300-010/8800-**	8848	13272	64	54	309:1
WGS-300-010/8800-**	8848	13272	32	27	309:1
WGS-301-010/10900-**	10949	16424	239	205	191:1
WGS-301-010/10900-**	10949	16424	159	130	191:1
WGS-301-010/10900-**	10949	16424	120	99	191:1
WGS-301-010/10900-**	10949	16424	80	67	191:1
WGS-301-010/10900-**	10949	16424	60	49	191:1
WGS-301-010/10900-**	10949	16424	40	33	191:1
WGS-301-010/10900-**	10949	16424	20	17	191:1
WGS-402-020/17400-**	17403	26105	249	204	299:1
WGS-402-020/17400-**	17403	26105	187	155	299:1
WGS-402-020/17400-**	17403	26105	125	104	299:1
WGS-402-020/17400-**	17403	26105	94	77	299:1
WGS-402-020/17400-**	17403	26105	62	52	299:1
WGS-402-020/17400-**	17403	26105	31	26	299:1
WGS-405-010/20900-**	20949	31424	948	813	758:1
WGS-405-010/20900-**	20949	31424	632	517	758:1
WGS-405-010/20900-**	20949	31424	474	392	758:1
WGS-405-010/20900-**	20949	31424	316	265	758:1
WGS-405-010/20900-**	20949	31424	237	196	758:1
WGS-405-010/20900-**	20949	31424	158	132	758:1
WGS-405-010/20900-**	20949	31424	79	66	758:1
WGS-500-010/34600-**	34600	51900	1525	1307	1219:1
WGS-500-010/34600-**	34600	51900	1017	832	1219:1
WGS-500-010/34600-**	34600	51900	762	631	1219:1
WGS-500-010/34600-**	34600	51900	508	426	1219:1
WGS-500-010/34600-**	34600	51900	381	315	1219:1
WGS-500-010/34600-**	34600	51900	254	213	1219:1
WGS-500-010/34600-**	34600	51900	127	106	1219:1
WGS-503-020/41200-**	41226	61839	562	459	673:1
WGS-503-020/41200-**	41226	61839	421	349	673:1
WGS-503-020/41200-**	41226	61839	281	235	673:1
WGS-503-020/41200-**	41226	61839	211	174	673:1
WGS-503-020/41200-**	41226	61839	140	118	673:1
WGS-503-020/41200-**	41226	61839	70	58	673:1
WGS-550-020/62300-**	62309	93464	1017	832	1219:1
WGS-550-020/62300-**	62309	93464	762	631	1219:1
WGS-550-020/62300-**	62309	93464	508	426	1219:1
WGS-550-020/62300-**	62309	93464	381	315	1219:1
WGS-550-020/62300-**	62309	93464	254	213	1219:1
WGS-550-020/62300-**	62309	93464	127	106	1219:1
WGS-552-030/63700-**	63756	95634	742	636	593:1
WGS-552-030/63700-**	63756	95634	494	404	593:1
WGS-552-030/63700-**	63756	95634	371	307	593:1
WGS-552-030/63700-**	63756	95634	247	207	593:1
WGS-552-030/63700-**	63756	95634	185	153	593:1
WGS-552-030/63700-**	63756	95634	124	103	593:1
WGS-552-030/63700-**	63756	95634	62	51	593:1

- (1) Complete the Code Model by replacing \*\* with the stroking time (sec per 90°) at the selected frequency.
- (2) Nominal output torque to be set between the 100% value reported in the table and the minimum value of 40%.
- (3) Theoretical max output torque. Based on motor power supply and output speed, the Max torque value may be from 1,4 to 2 times the Nominal Torque value.
- (4) The performances are relevant to Service ON-OFF S2-15' (CEI 2-3) or to Service Inching S4-25%-60 starts/hour (CEI 2-3).
- (5) Three-phase power supply from 208V to 690V at frequency 50/60Hz.
- (6) Ambient temperature from -40°C to +85°C.
- (7) Please consider a tolerance of +/- 5% on the reported stroking times.

# ICON 2000 ELECTRIC ACTUATORS

## WGS WORM GEAR REDUCER

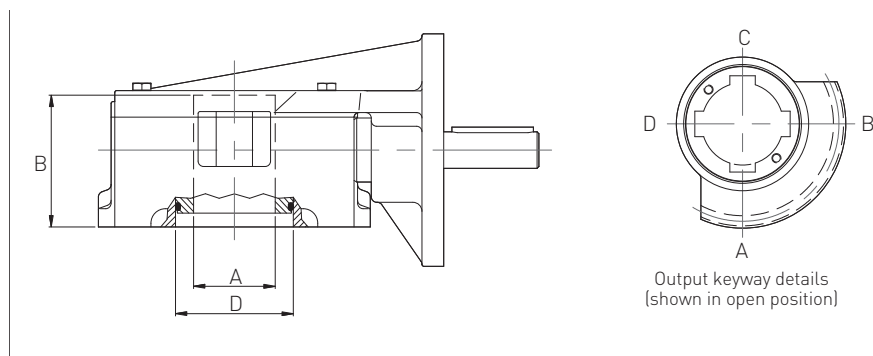

### WORM GEAR REDUCER TYPE WGS DRIVE SLEEVE DIMENSIONS

Model	Flange ISO		A (1)	A(2)	B(3)	D
	MIN	MAX				
WGS-100	F07	F10	32	25	57	50
WGS-120	F10	F14	45	32	72	65
WGS-140	F12	F16	65	45	81	90
WGS-150	F14	F16	86	70	92	115
WGS-160	F16	F25	92	75	113	120
WGS-200	F16	F25	92	-	116	120
WGS-302	F25	F30	124	-	144	155
WGS-300	F25	F30	124	-	144	155
WGS-301	F25	F30	124	-	144	155
WGS-402	F25	F40	165	-	203	205
WGS-405	F25	F40	165	-	203	205
WGS-500	F25	F48	180	-	250	225
WGS-503	F25	F48	180	-	250	225
WGS-550	F25	F48	180	-	250	225
WGS-552	F25	F48	180	-	250	225

### NOTES

1. Max stem diameter without drive bush
2. Max stem diameter with drive bush
3. Max valve stem height

# ICON 2000 ELECTRIC ACTUATORS

## WGS WORM GEAR REDUCER

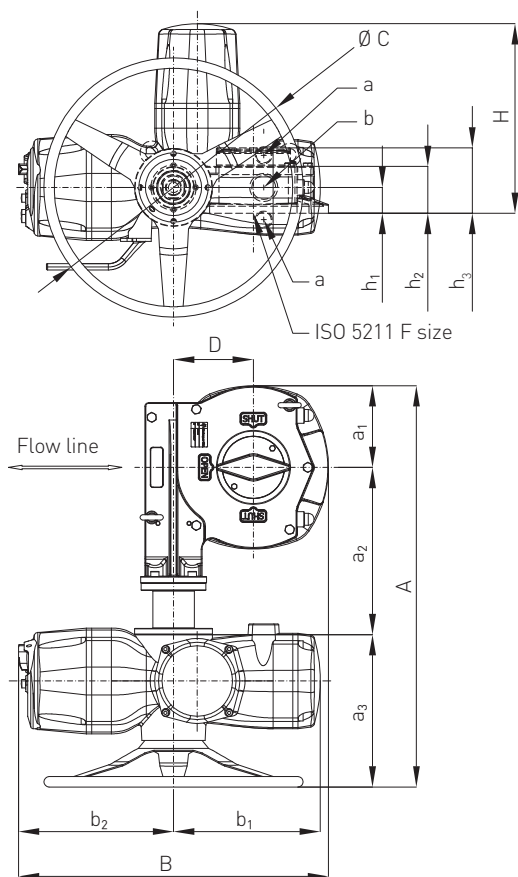

Cable entries:  
 a=1 NPT  
 b=1½ NPT  
 All dimensions are in mm

### WGS OVERALL DIMENSIONS, all dimensions are in mm

Model	A	a <sub>1</sub>	a <sub>2</sub>	a <sub>3</sub>	B	b <sub>1</sub>	b <sub>2</sub>	ØC	D	F	H	h <sub>1</sub>	h <sub>2</sub>	h <sub>3</sub>	Weight (Kg)
WGS-100	TEA	TBA	TBA	TBA	TBA	TBA	TBA	TBA	TBA	TBA	TBA	TBA	TEA	TBA	40
WGS-120	570	83	215	273	564	273	291	300	67	F10/F14	365	40	66	79	44
WGS-140	604	99	233	273	564	273	291	300	90	F14/F16	375	50	78	93	49
WGS-150	TBA	TBA	TBA	TBA	TBA	TBA	TBA	TBA	TBA	TBA	TBA	TBA	TEA	TBA	66
WGS-160	TBA	TBA	TBA	TBA	TBA	TBA	TBA	TBA	TBA	TBA	TBA	TBA	TEA	TBA	81
WGS-200	TBA	TBA	TBA	TBA	TBA	TBA	TBA	TBA	TBA	TBA	TBA	TBA	TEA	TBA	78
WGS-300/301/302	870	185	412	273	584	273	291	300	108	F25/F30	411	85	121	172	119
WGS-405	1034	243	519	273	590	273	291	300	70	F25/F40	434	108	144	224	214
WGS-402	1055	243	519	294	598	283	299	500	70	F25/F40	424	108	144	224	227
WGS-500	1155	307	575	273	686	273	291	300	125	F25/F48	461	135	171	272	326
WGS-503	TEA	TBA	TBA	TBA	TBA	TBA	TBA	TBA	TBA	TBA	TBA	TBA	TEA	TBA	339
WGS-550	TBA	TBA	TBA	TBA	TBA	TBA	TBA	TBA	TBA	TBA	TBA	TBA	TEA	TBA	339
WGS-552	TBA	TBA	TBA	TBA	TBA	TBA	TBA	TBA	TBA	TBA	TBA	TBA	TEA	TBA	364

# ICON 2000 ELECTRIC ACTUATORS

## ELGA SCOTCH YOKE REDUCER

Scotch yoke reducer for application on valves requiring high torques at stroke limits (Open/Close). Also used on quarter turn valves when very high torques are required.



### ICON 2000 SERIES ELGA ACTUATOR PERFORMANCE WITH THREE PHASE MOTOR<sup>[4]</sup>

Model <sup>[1]</sup>	Nom. torque <sup>[2]</sup> (100%) (Nm)			Max. torque <sup>[3]</sup> (Nm)	Op. time/90° <sup>**</sup> (50 Hz)	Op. time/90° <sup>**</sup> (60 Hz)	ICON 2000 model	Motor power (kW) (at 50 Hz)	Motor power (kW) (at 60 Hz)
	Break to open	Running	End to open						
ELGA-14KR-020/94000-**-**	94000	54300	82000	141000	865	721	ICON-020/180-24(29)	0.286	0.343
ELGA-14KR-020/94000-**-**	94000	54300	82000	141000	577	481	ICON-020/180-36(43)	0.367	0.440
ELGA-14KR-020/94000-**-**	94000	54300	82000	141000	433	361	ICON-020/180-48(58)	0.526	0.631
ELGA-14KR-020/94000-**-**	94000	54300	82000	141000	288	240	ICON-020/180-72(86)	0.789	0.947
ELGA-14KR-020/94000-**-**	94000	54300	82000	141000	144	120	ICON-020/180-144(173)	1.470	1.764
ELGA-14KR-030/94000-**-**	94000	54300	82000	141000	69	58	ICON-030/360-144(173)	3.368	4.042
ELGA-14KR-040/94000-**-**	94000	54300	82000	141000	42	35	ICON-040/720-144(173)	5.818	6.982
ELGA-18KR-020/133000-**-**	133000	77000	116000	199500	1330	1108	ICON-020/180-24(29)	0.286	0.343
ELGA-18KR-020/133000-**-**	133000	77000	116000	199500	887	739	ICON-020/180-36(43)	0.367	0.440
ELGA-18KR-020/133000-**-**	133000	77000	116000	199500	665	554	ICON-020/180-48(58)	0.526	0.631
ELGA-18KR-020/133000-**-**	133000	77000	116000	199500	443	369	ICON-020/180-72(86)	0.789	0.947
ELGA-18KR-020/133000-**-**	133000	77000	116000	199500	222	185	ICON-020/180-144(173)	1.470	1.764
ELGA-18KR-030/133000-**-**	133000	77000	116000	199500	133	111	ICON-030/360-144(173)	3.368	4.042
ELGA-18KR-040/133000-**-**	133000	77000	116000	199500	57	48	ICON-040/720-144(173)	5.818	6.982
ELGA-32KR-030/266000-**-**	266000	156000	238000	399000	1272	1060	ICON-030/360-36(43)	0.789	0.947
ELGA-32KR-030/266000-**-**	266000	156000	238000	399000	954	795	ICON-030/360-48(58)	1.123	1.348
ELGA-32KR-030/266000-**-**	266000	156000	238000	399000	636	530	ICON-030/360-72(86)	1.470	1.764
ELGA-32KR-030/266000-**-**	266000	156000	238000	399000	318	265	ICON-030/360-144(173)	3.368	4.042
ELGA-32KR-040/266000-**-**	266000	156000	238000	399000	181	151	ICON-040/720-144(173)	5.818	6.982
ELGA-32KR-050/266000-**-**	266000	156000	238000	399000	75	63	ICON-050/1440-144(173)	11.636	13.963
ELGA-50KR-030/334000-**-**	334000	197000	300000	501000	1280	1067	ICON-030/360-36(43)	0.789	0.947
ELGA-50KR-030/334000-**-**	334000	197000	300000	501000	960	800	ICON-030/360-48(58)	1.123	1.348
ELGA-50KR-030/334000-**-**	334000	197000	300000	501000	640	533	ICON-030/360-72(86)	1.470	1.764
ELGA-50KR-030/334000-**-**	334000	197000	300000	501000	320	267	ICON-030/360-144(173)	3.368	4.042
ELGA-50KR-040/334000-**-**	334000	197000	300000	501000	152	127	ICON-040/720-144(173)	5.818	6.982
ELGA-50KR-050/334000-**-**	334000	197000	300000	501000	65	54	ICON-050/1440-144(173)	11.636	13.963

#### NOTES

1. The \*\* are to be replaced by operating time value at selected frequency (50 or 60 Hz)
2. Nominal output torque settable from 40% (minimum torque) to 100% of indicated value
3. Theoretic max output torque. The actual max output torque is a function of speed and motor power supply and may vary from 1.3 to 2 times nominal output torque
4. The performance table above relates to ON/OFF S2-15' or INCHING S4-25%-60 starts/hour duties (IEC34-1)

# ICON 2000 ELECTRIC ACTUATORS

## ELGA DRIVE SLEEVE DIMENSIONS

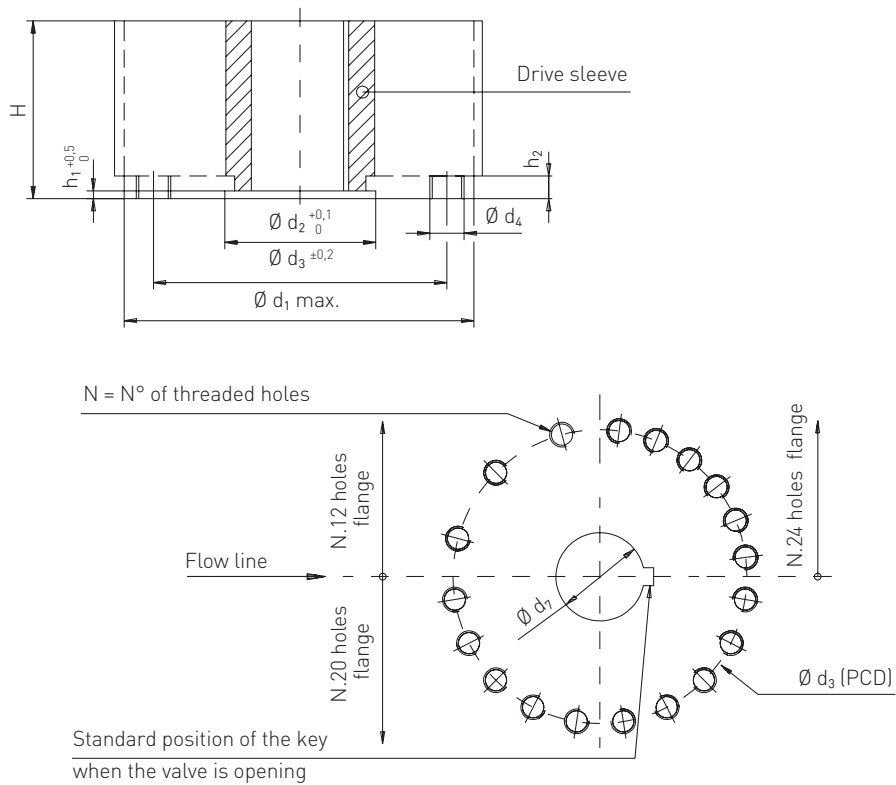

### ICON 2000 SERIES ELGA - METRIC (mm)

Model	Elga 14	Elga 18	Elga 32	Elga 50
ISO 5211 <sup>[2]</sup>	F48	F60	F60	SPECIAL
$\varnothing d_1$	580	680	780	800
$\varnothing d_2$ <sup>[5]</sup>	250	290	290	315
$\varnothing d_3$	483	603	603	698
$\varnothing d_4$ <sup>[6]</sup>	M36	M36	M36	M36
$h_1$ <sup>[5]</sup>	10	12	12	10
$h_2$	29	32	32	32
$N$	12	20	20	24
$H$	340	350	400	430
$d_7$ max stem accept. - rectangular key UNI/DIN <sup>[3]</sup>	$\varnothing 200$	$\varnothing 220$	$\varnothing 230$	$\varnothing 255$
$d_7$ max stem accept. - square key <sup>[4]</sup>	$\varnothing 175$	$\varnothing 190$	$\varnothing 200$	$\varnothing 225$
$d_7$ max stem accept. - square stem	150	170	175	190

### NOTES

1. Drive sleeve supplied by Biffi with unmachined bore. Machining of bore upon request
2. Different values of flange dimensions can be supplied on request
3. Keyway for rectangular key, according to DIN 6885 SH.1 or BS 4235 or UNI 6604 or equivalent
4. Keyway for square key according to ANSI B17.1-1967 or equivalent
5. Female spigot supplied as a standard. Male spigot supplied on request
6. Fixing bolts or rods supplied by Biffi only on request, minimum material class required 8.8 UNI37409, ASTM A320-L7

# ICON 2000 ELECTRIC ACTUATORS

## ELGA OVERALL DIMENSIONS

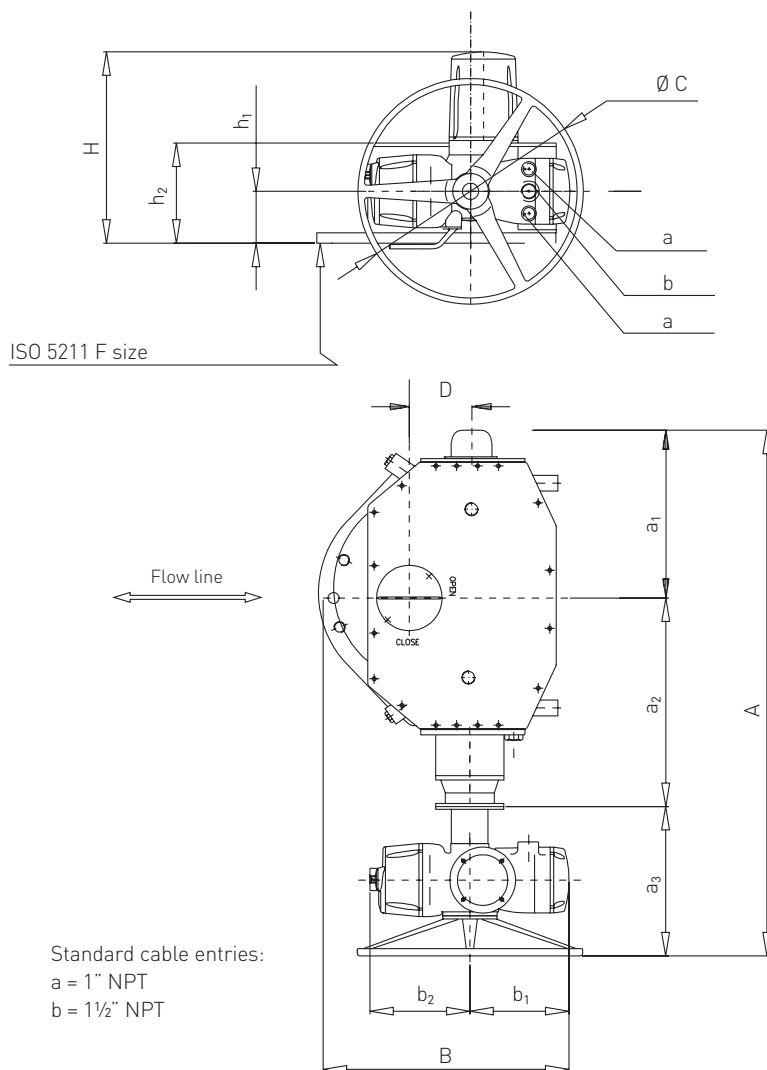

**ICON 2000 SERIES ELGA OVERALL DIMENSIONS - METRIC (mm / kg)**

Model	A	a <sub>1</sub>	a <sub>2</sub>	a <sub>3</sub>	B	b <sub>1</sub>	b <sub>2</sub>	Ø C	D	F	H	h <sub>1</sub>	h <sub>2</sub>	Mass (kg)
14KR-020	1619	536	778	305	772	283	300	500	200	F48	463	166	320	650
14KR-030	1653	536	778	339	793	313	312	600	200	F48	476	166	320	660
14KR-040	1712	536	778	398	835	318	372	720	200	F48	627	166	320	670
18KR-020	1727	583	839	305	852	283	300	500	230	F60	542	195	383	800
18KR-030	1761	583	839	339	873	313	312	600	230	F60	595	195	383	810
18KR-040	1820	583	839	398	915	318	372	720	230	F60	656	195	383	820
32KR-030	1.964	663	1.124	339	863	313	312	600	270	F60	632	232	464	960
32KR-040	2.064	663	1.164	398	1005	318	372	720	270	F60	693	232	464	970
32KR-050	2.185	663	1.244	478	1049	363	392	860	270	F60	750	232	464	980
50KR-030	2.340	710	1.291	339	1003	313	312	600	300	SPEC.	633	233	561	1180
50KR-040	2.439	710	1.331	398	1045	318	372	720	300	SPEC.	694	233	561	1190
50KR-050	2.599	710	1.411	478	1089	363	392	860	300	SPEC.	751	233	561	2000

# ICON 2000 ELECTRIC ACTUATORS

## ICON 2000L LINEAR ACTUATOR

For specific application on linear valves (gate, globe...) with non-threaded stem, generally to replace piston or diaphragm pneumatic actuators.



### ICON 2000L LINEAR ACTUATOR PERFORMANCE WITH THREE PHASE MOTOR<sup>[3]</sup>

Model <sup>[1]</sup>	Nominal thrust <sup>[2]</sup> (100%) (kN)	Min. thrust (40%) (kN)	Linear speed <sup>[4]</sup> **		Motor power (kW) (at 50 Hz)	Motor power (kW) (at 60 Hz)	R
			(mm/secs) (at 50 Hz)	(mm/secs) (at 60 Hz)			
ICON-010L/10-**	10	4	0.6	0.7	0.030	0.036	40:1
ICON-010L/10-**	10	4	0.9	1.1	0.046	0.055	40:1
ICON-010L/10-**	10	4	1.2	1.4	0.071	0.085	20:1
ICON-010L/10-**	10	4	1.8	2.2	0.106	0.127	20:1
ICON-010L/10-**	10	4	2.4	2.9	0.142	0.170	20:1
ICON-010L/10-**	10	4	3.6	4.3	0.213	0.256	20:1
ICON-010L/40-**	40	16	0.6	0.7	0.071	0.085	40:1
ICON-010L/40-**	40	16	0.9	1.1	0.106	0.127	40:1
ICON-010L/40-**	40	16	1.2	1.4	0.122	0.146	20:1
ICON-010L/40-**	40	16	1.8	2.2	0.184	0.221	20:1
ICON-010L/40-**	40	16	2.4	2.9	0.286	0.343	20:1
ICON-010L/40-**	40	16	3.6	4.3	0.367	0.440	20:1
ICON-020L/60-**	60	24	1.2	1.4	0.184	0.221	40:1
ICON-020L/60-**	60	24	1.6	1.9	0.286	0.343	40:1
ICON-020L/60-**	60	24	2.4	2.9	0.367	0.440	40:1
ICON-020L/60-**	60	24	3.2	3.8	0.526	0.631	20:1
ICON-020L/60-**	60	24	4.8	5.8	0.789	0.947	20:1
ICON-030L/90-**	90	36	1.0	1.2	0.526	0.631	80:1
ICON-030L/90-**	90	36	2.0	2.4	0.526	0.631	40:1
ICON-030L/90-**	90	36	4.0	4.8	1.123	1.348	20:1
ICON-030L/90-**	90	36	6.0	7.2	1.470	1.764	40:1
ICON-040L/150-**	150	60	2.4	2.9	0.840	1.008	40:1
ICON-040L/150-**	150	60	3.2	3.8	1.123	1.348	40:1
ICON-040L/150-**	150	60	4.8	5.8	1.684	2.021	40:1
ICON-040L/150-**	150	60	6.4	7.7	1.939	2.327	20:1
ICON-040L/150-**	150	60	9.6	11.5	3.368	4.042	40:1

#### NOTES

1. The \*\* are to be replaced by linear speed value at selected frequency (50 or 60 Hz)
2. Nominal output thrust settable from 40% (minimum thrust) to 100% of indicated value
3. The performance table below relates to ON/OFF S2-15' or INCHING S4-25%-60 starts/hour duties (IEC34-1)
4. Referred to Running thrust = 40% nominal thrust
5. Modular duty version available on request

# ICON 2000 ELECTRIC ACTUATORS

## ICON 2000L LINEAR ACTUATOR DIMENSIONS

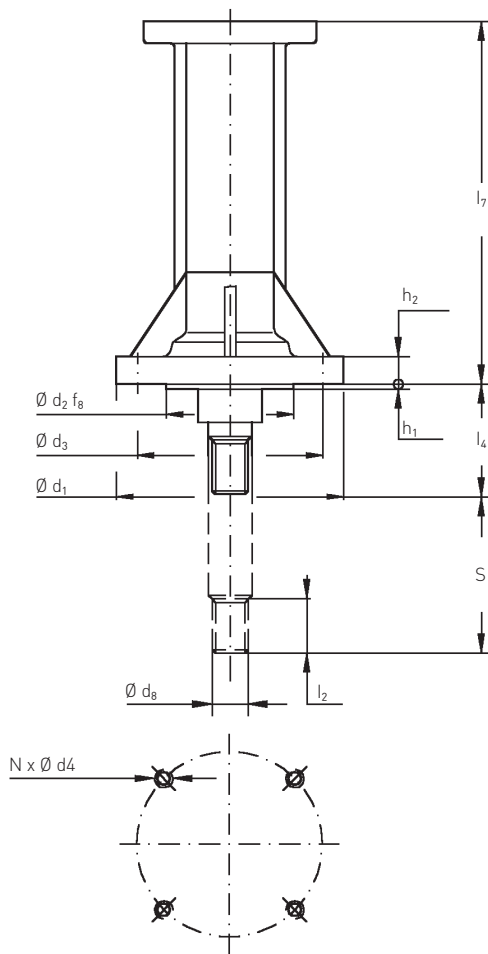

### ICON 2000L LINEAR ACTUATOR - METRIC (mm / kg)

Model	010L	020L	030L	040L
ISO 5210 / DIN3358	F10	F14	F14	F16
$F_{nom}$ (kN)	40	60	80	150
$F_{max}$ (kN)	60	90	135	225
$\varnothing d_1$	125	175	175	210
$\varnothing d_2 f_8$	70	100	100	130
$\varnothing d_3$	102	140	140	165
$\varnothing d_4$	M10	M16	M16	M20
$\varnothing d_8$ (left)	M20x1.5	M36x3	M36x3	M42x3
$h_1$	3	4	4	4
$h_2$	15	24	24	30
$l_7$	265	375	480	580
$l_2$	25	55	55	65
$l_4$	35	60	60	80
N	4	4	4	4
S (max stroke)	100	160	200	300
Mass (kg)	10	18	22	28

#### NOTES

1. The stem is drawn in fully retracted position.
2. The stem end ( $\varnothing d_8$ ) is left hand thread
3. Only axial loads are permitted
4.  $F_{nom}$  = the maximum thrust applicable to the linear thrust block in dynamic conditions with torque control set at 100%  
 $F_{max}$  = the maximum thrust applicable to the linear thrust block in static conditions with manual override or with motor in stall torque



Biffi reserve the right to change product designs and specifications without notice.

**Biffi Italia S.r.L.**

Località Caselle San Pietro, 420, 29017 Fiorenzuola d'Arda (PC) ITALY Ph: +39 (0)523 944 411 E-mail: [biffi\\_italia@biffi.it](mailto:biffi_italia@biffi.it) [www.biffi.it](http://www.biffi.it)