

# TEC2 Electric Actuator with Model 500 (Model 500 Discontinued)





# Table of Contents

## Section 1: Important Notes

1.1	User Safety.....	1
1.2	Purpose.....	1
1.3	Storage Procedures.....	2

## Section 2: Quick Start

2.1	Set Position Limits.....	3
2.2	Network Setup.....	8
2.3	Check Settings.....	8

## Section 3: Installation

3.1	Preparing the Stem Nut.....	9
3.2	Mechanical Installation onto the Valve.....	10
3.3	Electrical Connections.....	11
3.3.1	Remove Separate Terminal Chamber (STC) Cover.....	11
3.3.2	Sealing Cable/Conduit Entries.....	12
3.3.3	Recommended Terminal Connections.....	12
3.3.4	Cable Connections.....	13
3.3.5	Replace Terminal Compartment Cover.....	13
3.3.6	External Earth/Ground Connections.....	13
3.4	Display Backup Module (DBM) – Optional.....	14
3.5	Discrete Controlled Inputs.....	15
3.6	Auxiliary Control Module (ACM) – Optional.....	17
3.6.1	Wiring the ACM.....	17
3.6.2	Analog Controlled – Power Supply Connections.....	19
3.6.3	Network Controlled.....	22
3.7	Auxiliary Relay Module (ARM) Wiring.....	23
3.8	Remote Display Module (RDM) Connection to the Actuator – Optional.....	25
3.8.1	24 Vdc Power Source.....	26
3.8.2	115/230 Vac Power Source.....	27
3.8.3	Two RDMs (One 24 Vdc and One 115/208/220/230 Vac Power Source).....	27
3.8.4	RDM Connections and Dip Switch Settings.....	27

## Section 4: Operation

4.1	Local Display Module Display Module with Bluetooth® - Model 87340 .....	29
4.1.1	Graphics Display and Message Center .....	30
4.1.2	Control Knob and Selector Knob .....	30
4.1.3	LEDs .....	30
4.1.4	Normal Display Function .....	31
4.2	Remote Display Module (RDM) Display Module with Bluetooth® - Model 87340 ...	32
4.2.1	RDM Operation with LDM .....	32
4.3	Initializing the Actuator .....	33
4.3.1	Setting Position Limits .....	33
4.3.2	View Existing Settings .....	33
4.4	Local Control Operation .....	37
4.5	Remote/Auto Control Operation .....	38

## Section 5: Customizing Actuator Settings

5.1	Entering Setup Mode .....	40
5.2	Setting Limits .....	42
5.3	Changing Display .....	42
5.4	Displaying Unit Parameters .....	43
5.5	Change Settings .....	45
5.5.1	Passcode Entry .....	47
5.5.2	Valve Control Setup .....	48
5.5.3	Set Valve Travel Limits .....	50
5.5.4	Discrete Input Setup .....	52
5.5.5	Discrete Output Setup .....	53
5.5.6	Inhibit and ESD Setup .....	56
5.5.7	Two-Speed Timer Setup .....	58
5.5.8	Analog Setup (ACM Required) .....	59
5.5.9	Network Setup (CAM and Controlinc ACM Required) .....	65
5.5.10	Tag Name Setup .....	67
5.5.11	Passcode Setup .....	69
5.5.12	Reload Factory Settings .....	71

## Section 6: Troubleshooting

6.1	Troubleshooting Problems/Corrective Action for Actuator Operation .....	72
6.2	Display Diagnostics .....	73
6.2.1	Display Alarm Log .....	74
6.2.2	Display Torque Profile .....	75
6.2.3	Display Torque Archive .....	76
6.2.4	Display Operation Log .....	76
6.2.5	Display Operation Archive .....	77
6.2.6	Display Hardware .....	77



## Section 7: Maintenance

7.1	Maintenance Schedule .....	79
7.2	Lubrication.....	79
7.3	Pressure Relief.....	79
7.4	Fuse Replacement .....	79
7.5	Lifting .....	80
7.6	Battery Disposal .....	80
7.7	Cleaning of LDM.....	80
7.8	Improper Use .....	80
7.9	Battery Replacement – “Clicker” .....	80

## Section 8: Regulatory Information

### Appendix A:

A.1	Exploded View (Model-500 Torque Unit Only).....	82
A.2	M-500 with Thrust Base Installation Drawing .....	83
A.3	Module Identification and Location .....	85
A.4	Infrared Controller (IRC) – “Clicker” .....	86
A.5	IrDa Port .....	87
A.6	Disconnect - Circuit Breaker .....	87
A.7	Common Bolt Tightening Torques.....	89
A.8	Bluetooth Specifications .....	91

# List of Figures

Figure 2-1 Declutch Lever and Handwheel .....	5
Figure 2-2 Setting Limits – Electrical Operation .....	6
Figure 2-3 Setting Limits – Manual Operation .....	7
Figure 3-1 Preparing the Stem Nut .....	9
Figure 3-2 Removal of STC Cover .....	11
Figure 3-3 Power Terminal Connections .....	13
Figure 3-4 Control Terminal Connections .....	13
Figure 3-5 Earth/Ground Connection .....	14
Figure 3-6 Control Input Wiring .....	15
Figure 3-7 Inhibit and ESD Wiring .....	16
Figure 3-8 TEC2 PST Wiring Diagram .....	16
Figure 3-9 ACM Wiring Connections - ACM (Analog Control Module) .....	17
Figure 3-10 ACM Installation Connections - ACM (Network Control Module) .....	18
Figure 3-11 ACM Wiring Connections .....	18
Figure 3-12 ACM – Analog Output with External Power Supply .....	19
Figure 3-13 ACM – Analog Output with Internal Power Supply .....	19
Figure 3-14 ACM – Analog Input with External Power Supply .....	20
Figure 3-15 ACM – Analog Input with Internal Power Supply .....	20
Figure 3-16 Futronic – 3 Wire Analog Control with External Power Supply .....	21
Figure 3-17 Futronic – 3 Wire Analog Control with Internal Power Supply .....	21
Figure 3-18 ARM Wiring Diagram .....	23
Figure 3-19 ARM Wiring Connections .....	24
Figure 3-20 Connecting RDM Cables to the STC .....	25
Figure 3-21 RDM Interface Module (Support Both 24V DC and AC) .....	26
Figure 3-22 TEC2 Wiring Diagram .....	28
Figure 4-1 TEC2 Controller .....	29
Figure 4-2 Local Display Module (LDM) .....	29
Figure 4-3 Normal Display .....	31
Figure 4-4 Display Settings .....	36

## List of Figures (*continuation*)

Figure 5-1 Setup .....	41
Figure 5-2 Change Display .....	43
Figure 5-3 Displaying Unit Parameters .....	44
Figure 5-4 Change Settings .....	46
Figure 5-5 Passcode Entry .....	48
Figure 5-6 Valve Control Setup .....	49
Figure 5-7 Set Valve Travel Limits (Normal Operation Mode - Set Limits with Electrical Operation) ....	50
Figure 5-8 Set Valve Travel Limits (Normal Operation Mode - Set Limits with Handwheel Operation) ....	51
Figure 5-9 Discrete Input Setup .....	52
Figure 5-10 Discrete Output Setup .....	55
Figure 5-11 Inhibit and ESD Setup .....	57
Figure 5-12 Two-Speed Timer Setup .....	58
Figure 5-13 Analog Setup .....	60
Figure 5-13-1 Analog Input 1 Calibration Setup .....	61
Figure 5-13-2 Analog Input 2 Calibration Setup.....	62
Figure 5-13-3 Analog Output 1 Calibration Setup.....	63
Figure 5-13-4 Analog Output 2 Calibration Setup.....	64
Figure 5-14 Network Setup .....	66
Figure 5-14-1 Network Setup Display Menu .....	67
Figure 5-15 Tag Name Setup Menu .....	68
Figure 5-16 Passcode Setup Menu .....	69
Figure 5-17 Battery Enable Menu .....	70
Figure 5-18 Set Time and Date Menu .....	70
Figure 5-19 Bluetooth .....	71
Figure 6-1 Display Diagnostic .....	73
Figure 6-2 Display Alarm Log Example .....	74
Figure 6-3 Display Torque Profile .....	75
Figure 6-4 Display Operation Log .....	76
Figure 6-5 Display Operation Archive .....	77
Figure 6-6 Display Hardware .....	78
Figure 7-1 Fuses in the STC .....	80
Figure A-1 Clicker .....	86
Figure A-2 Circuit Breaker Module (CBM) .....	88

# List of Tables

Table 3-1 Connecting Actuator A to Actuator B .....	22
Table 3-2 ARM Wiring Connections .....	23
Table 3-3 RDM Connections with Internal Power Source (24VDC) .....	27
Table 3-4 RDM Connections with External Power Source (External AC) .....	27
Table 3-5 Dip Switch (SW5 and SW6) Settings .....	27
Table 4-1 LDM Rotating Knobs .....	30
Table 4-2 Normal Display Functions .....	31
Table 4-3 RDM and LDM Operation Priority .....	32
Table 4-4 Default Configuration Settings .....	34
Table 5-1 Relay Outputs #1 through #5 Configuration .....	53
Table 5-2 Relay Output Function List .....	54
Table 5-3 Relay Outputs #9 through #12 Configuration .....	56

# Section 1: Important Notes

## 1.1 User Safety

Safety notices in this manual detail precautions the user must take to reduce the risk of personal injury and damage to the equipment. The user must read these instructions in their entirety. Failure to observe these safety notices could result in serious bodily injury, damage to the equipment, void of the warranty, or operational difficulty.

Safety notices are presented as follows:

### **⚠ WARNING:**

Alerts user of potential danger; failure to follow the warning notice could result in serious personal injury or death.

### **⚠ CAUTION:**

Identifies precautions the user must take to avoid personal injury or equipment damage.

### **NOTE:**

Highlights information critical to the user's understanding of the TEC2 valve actuator installation or operation.

## 1.2 Purpose

This installation and operation manual explains how to install, operate, and maintain the TEC2 valve actuator.

TEC2 actuators are intended for automating part-turn and multi-turn valves within the specified torque ranges for given model.

### **⚠ WARNING:**

**Read this manual in its entirety before installing, operating, or performing maintenance on the TEC2 valve actuator.**

**Use caution when working on, with, or around valves and actuators. High pressures, forces, voltages, and flammable media can be present.**

**Failure to follow instructions for proper electrical wiring, storage, setup, and maintenance may cause serious injury, damage equipment, or void warranty.**

**Installation, Operation and Maintenance should only be performed by qualified personnel.**

## 1.3 Storage Procedures

If your actuator cannot be immediately installed, the following procedures are to be followed. This will ensure optimum performance from your TEC2 actuator. Failure to comply with recommended procedures could lead to actuator malfunction and will void the warranty. For storage procedures exceeding one year, contact your local Emerson Representative for recommendations.

The TEC2 actuator is a double-sealed and inherently weatherproof unit when shipped from the factory, providing that all compartment covers and cable entry plugs remain intact.

The actuator should be immediately stored in a clean, dry warehouse, free from vibration and rapid temperature changes, until it can be installed and energized.

If the actuator must be stored outside, it should be stored off of the ground at an elevation sufficient to prevent it from being immersed in water or buried in snow, and covered to prevent damage from site debris.

If not attached to a valve, the preferred orientation is with the motor and electrical compartment horizontal.

If the actuator is mounted on a valve and the valve stem protrudes from the unit, a suitable stem protector must be installed to prevent drive-sleeve corrosion.

## Section 2: Quick Start

The **Quick Start Section** provides step-by-step instructions for initializing the TEC2 actuator. When these instructions are complete, the position limits will be set and the actuator will be ready for normal operation.

---

### NOTE:

The actuator has been configured as specified by the customer and no further changes should be required. If full valve data was not provided, actuator will be shipped with default configuration per **Table 4.4, Default Configuration Settings**, unless specific configuration was requested.

---

### WARNING:

Use caution when working on, with, or around valves and actuators. High pressures, forces, voltages, and flammable media can be present.

---

### WARNING:

Verify voltage rating on nameplate before connecting power.

---

## 2.1 Set Position Limits

- 1) Power actuator. The alarm message “**SET LIMITS BEFORE OPERATING**” will be displayed. The alarm icon and the yellow LED will be flashing. Valve position will be displayed as “**EE%**”.
- 2) The instruction is based on valve being in closed position. If valve is at “**Open**” end of travel, you must move the valve in “**Close**” direction and set a dummy close limit. Then move back to “**Open**” and set the open limit. Save the limits. Proceed as follows to set the limits. See **Section 5.5.3, Set Valve Travel Limits** for additional details.
  - A) Enter the “**SETUP**” mode.
    - 1) Place the selector knob in the **STOP** position.
    - 2) Rotate the control knob to **YES**, then **NO**, then **YES**, then **NO** in rapid succession and then release. The Setup icon will be displayed on the display module and “**SETUP?**” will be displayed on the message center.
    - 3) Rotate the control knob to **YES**. “**SET LIMITS BEFORE OPERATING**” will be displayed on the message center.
    - 4) Rotate the control knob to the **LOCAL** position. The message “**CLOSE VALVE THEN SELECT STOP**” will be displayed.
  - B) Set close valve travel limit.

**⚠ CAUTION:**

**It is recommended the valve be positioned using the handwheel while setting the limits to prevent valve damage.**

- 1) Valve Operation
    - A) For **Electrical Operation** use the control knob to move the valve in the close direction. Proceed to Step No. 2.
    - B) For **Manual Operation** depress the declutch lever while rotating the handwheel until the clutch is fully engaged. Release the lever. The clutch will be retained in the handwheel mode by spring-loaded latches. Verify the valve is fully closed. Move the valve in the open direction for one handwheel turn to allow for coasting of the motor.
  - 2) When the desired close position is reached, place the selector knob in the **STOP** position. “**ACCEPT CLOSE LIMIT?**” will be displayed.
  - 3) Rotate the control knob to **YES**. “**SELECT LOCAL AND OPEN VALVE**” will be displayed. The close limit is set.
- C) Set open valve travel limit.
- 1) Valve Operation
    - (1) For **Electrical Operation** use the control knob to move the valve in the open direction. Proceed to Step No. 2.
    - (2) For **Manual Operation** depress the declutch lever while rotating the handwheel until the clutch is fully engaged. Release the lever. The clutch will be retained in the handwheel mode by spring-loaded latches. Verify the valve is fully opened. Move the valve in the close direction for one handwheel turn to allow for coasting of the motor.
  - 2) When the desired open position is reached, place the selector knob in the **STOP** position. “**ACCEPT OPEN LIMIT?**” will be displayed.
  - 3) Rotate the control knob to **YES**. “**SAVE LIMITS?**” will be displayed.
  - 4) Rotate the control knob to **YES**.

The position limits are now set. The actuator will operate in the normal LOCAL and REMOTE modes.



**NOTE:**

The user is not required to exit setup after setting limits for the first time. At the completion of setting the limits, the actuator should be in the “STOP” mode and the valve should be at its open limit. The LDM should display “100%,” and the red LED should be ON. The graphics display of the valve should represent full open.

**Figure 2-1 Declutch Lever and Handwheel**



**TEC2000/TEC2 Enclosure**



**TEC2000/TEC2 Enclosure**



**Model 500 Enclosure**

Figure 2-2 Setting Limits - Electrical Operation

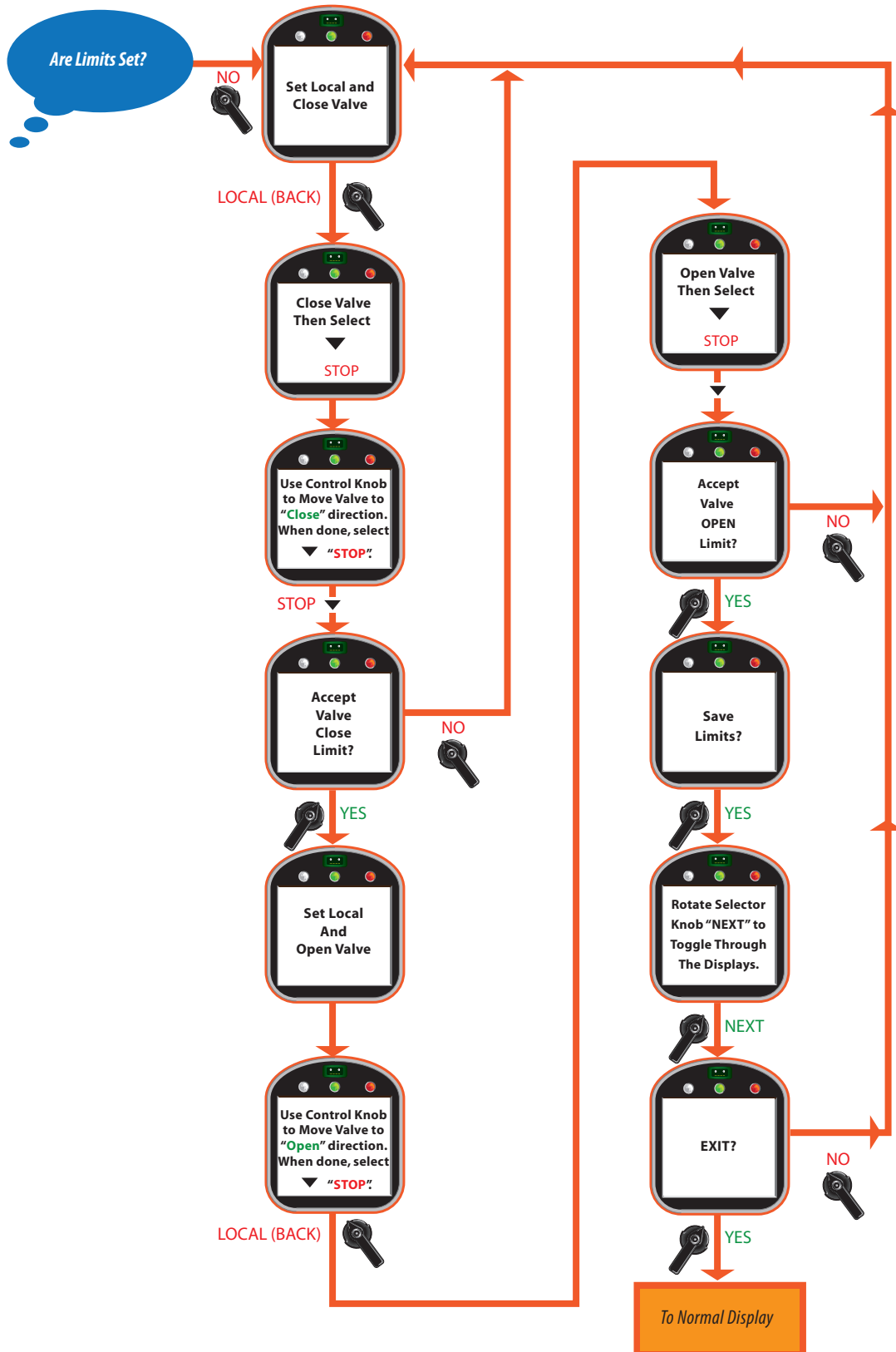
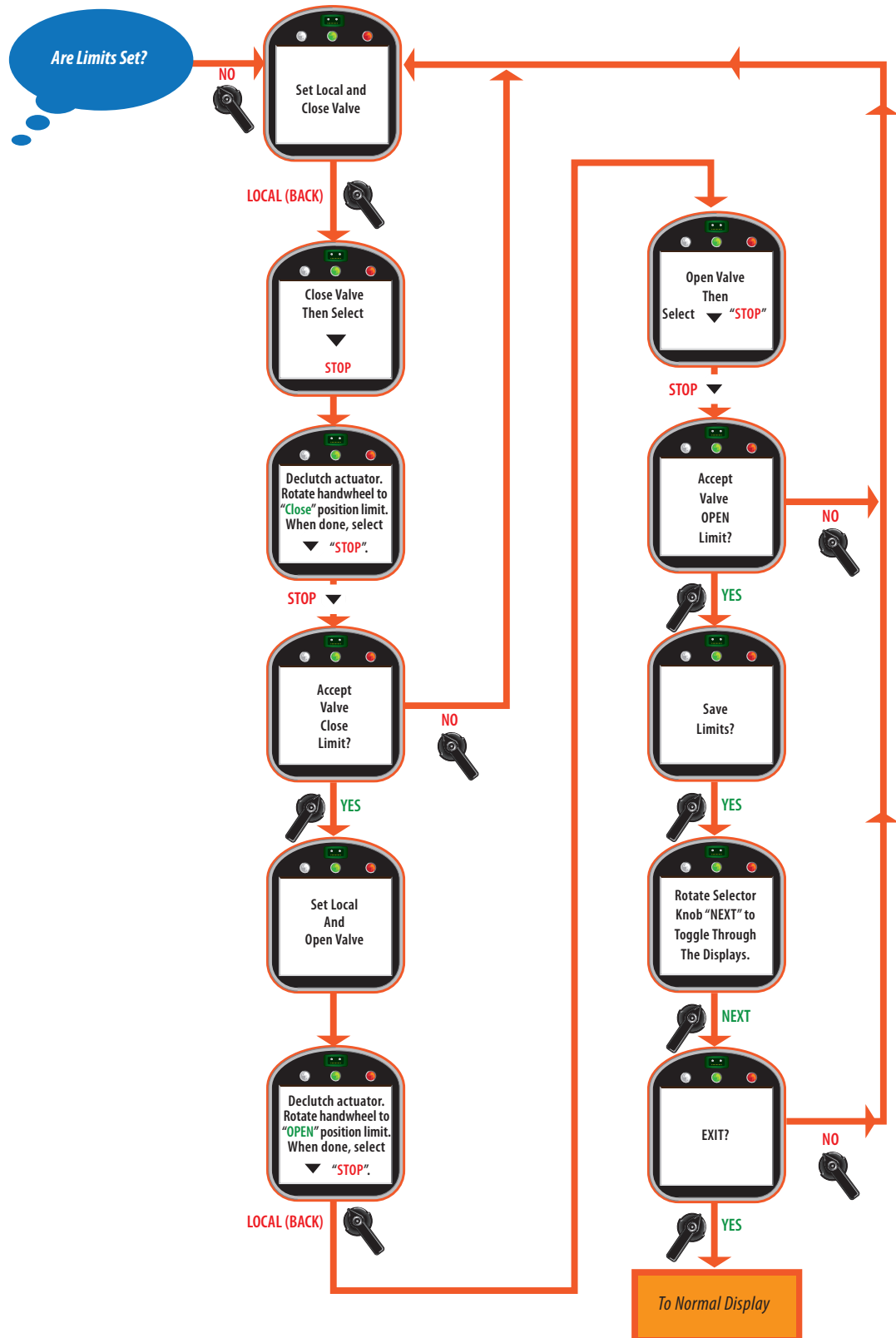


Figure 2-3 Setting Limits - Manual Operation



## 2.2 Network Setup

This is only applicable if the Controlinc Auxiliary Control Module (ACM) and the Communication Adapter Module (CAM) are installed and enabled. These instructions assume all parameters have been set with the exception of the network node address.

1. Remain in the “**SETUP**” mode.
2. Select **NEXT** to advance through the displays until “**NETWORK SETUP?**” appears.
3. Rotate the control knob to **YES**. “**NETWORK NODE ADDRESS XXX**” appears.
4. Rotate the control knob to **NO** to increment the address numbers. Hold in the **NO** position until the desired address is reached.

---

**NOTE:**

If the desired address is a lower number than what is displayed, continue to increment the numbers until the highest numbered address is reached. The address numbers will then start with the lowest numbered address and continue to increment.

---

5. When the correct address is displayed, rotate the control knob to **YES**.

## 2.3 Check Settings

1. Operate the valve to the fully close position.
2. Verify the green LED is ON (default setting) and 0% is displayed.
3. Operate the valve to the fully open position.
4. Verify the red LED is ON (default setting) and 100% is displayed.

## Section 3: Installation

### ⚠ WARNING:

Failure to follow instructions for proper electrical wiring, storage, setup, and maintenance may cause serious injury, damage equipment, or void warranty.

### ⚠ WARNING:

Use caution when working on, with, or around valves and actuators. High pressures, forces, voltages, and flammable media can be present.

## 3.1 Preparing the Stem Nut

### NOTE:

The actuator can be direct mounted to the valve shaft or stem, or can be close coupled to the auxiliary gear drives. See **Appendix** for the appropriate drawings.

Figure 3-1 Preparing the Stem Nut



TEC2000/TEC2 Enclosure



Model 500 Enclosure

1. Unscrew **Locknut** (piece #55) while holding **Bronze Stem Nut** (piece #54) or Steel Bore and Key Bushing. Remove the **Stem Nut** and **Key** (piece #52).
2. Lubricate **Stem**. Run **Stem Nut** (piece #54) down **Stem** to verify Acme thread fit. Remove **Stem Nut** (piece #54) and set aside.
3. Model 3000-8000 may include thrust base assemblies. See **Appendix** for instructions.

## 3.2 Mechanical Installation onto the Valve

1. Lower actuator over **Stem** onto valve flange.
2. Insert the screws through the valve flange into the actuator and engage at least one full screw diameter deep into the bottom base.
3. Tighten to a preload.  
See **Appendix** for common bolt tightening torques.

---

### NOTE:

Mounting screws are provided only if EIM supplied the adapter. Verify screws are through the adapter; engage a minimum of one screw diameter deep into the actuator base.

---

4. Screw the **Stem Nut** (piece #54) onto the **Stem** until it enters the **Drive Sleeve**.
5. Place Key (piece #52) in line with the **Drive Sleeve Keyway**. Insert **Key** (piece #52).
6. Turn the Handwheel in the Open direction to pull the **Stem Nut** (piece #54) into the **Drive Sleeve** until it bottoms out.

---

### NOTE:

Valve will begin to open.

---

7. Place the **Locknut** (piece #55) over the **Valve Stem**. Screw the **Locknut** (piece #55) firmly into place against the top of the **Stem Nut** (piece #54) using a drift to tighten.
8. Use a number 30 (0.1285) drill bit: drill a hole 3/4 inch (19mm) deep into the **Drive Sleeve** assembly threads for the Locknut Lockpin (piece #56). Use the groove in the **Stem Nut Locknut** threads as a guide.
9. Install **Locknut Lockpin** (piece #56) into drilled hole to prevent the **Stem Nut Locknut** (piece #55) from working loose and turning.

---

### NOTE:

When installing, the **Locknut Lockpin** (piece #56) should extend 1/4 inch (6mm) inch above the **Drive Sleeve** assembly to allow for easy removal.

---

### CAUTION:

**Locknut must be screwed very tightly against stem nut.**

---

## 3.3 Electrical Connections

### 3.3.1 Remove Separate Terminal Chamber (STC) Cover

**⚠ WARNING: BEWARE OF MULTIPLE POWER SOURCES**

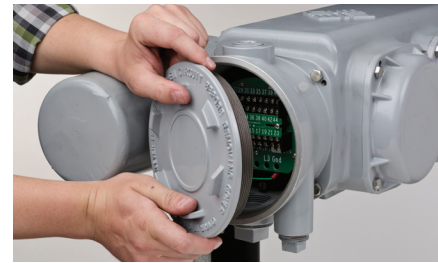
Verify power is disconnected before removing STC Cover.  
Multiple power sources may exist under the cover.

**NOTE:**

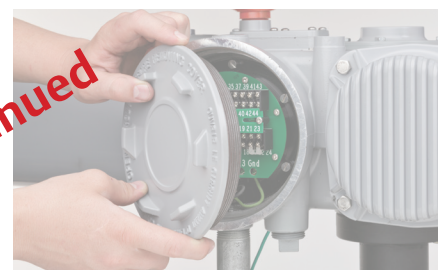
Valve actuator requires a circuit breaker within the line of sight, sized for the motor currently specified on the nameplate.  
See **Appendix Section A.7**, for the circuit breaker options.

Remove cover with a strap wrench, drift, or pinch bar by rotating the cover counterclockwise.

**Figure 3-2 Removal of STC Cover**



**TEC2000/TEC2 Enclosure**



**Model 500 Enclosure**

### 3.3.2 Sealing Cable/Conduit Entries

Seal the cable and conduit entries in accordance with the National Electric Code or your country standard and applicable local codes. All conduit entries should be sealed against the site environment. All unused conduit entries must be sealed with threaded metal plugs.

### 3.3.3 Recommended Terminal Connections

The TEC2 terminal block connectors are wire binding screw connectors with rising captive plates. Connections can be made one of three ways:

- Strip and connect bare wire
  - Strip and install wire ferrule
  - Strip and install crimp-on insulated or non-insulated ring or fork-tongue connectors for either M3 control signal terminal block screws or M4 power terminal screws.
1. Loosen terminal block connectors L1, L2, L3 and GND screws with a common or Phillips head screwdriver.
  2. If bare wire is being used, strip insulation a maximum of 0.4 inch (10 mm).
  3. Insert wire or wire lug under terminal block connector screw clamps and tighten.

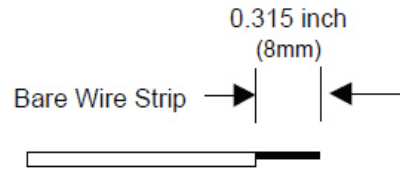
**Figure 3-3** details power terminal size and length of bare wire strip. **Figure 3-4** details control terminal size and length of bare wire strip.



---

**Figure 3-3 Power Terminal Connections**

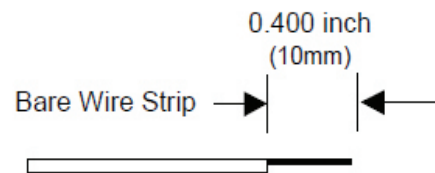
Terminal Size: 0.315 (M3)



---

**Figure 3-4 Control Terminal Connections**

Terminal Size: 0.375 (M4)



---

### 3.3.4 Cable Connections

1. Connect the main power supply cables, including the earth/ground wire using #1 Phillips or 3/16 inch (5mm) slotted tip screwdriver.
2. Attach earth/ground wire to internal ground lug using 1/4 inch #11 slotted screwdriver.
3. Use the barrier strip clamp screws to connect the control wires.
4. Ensure all connections are hand tight, including any unused terminal connections.

The main power supply and ground wire connections are screw size M4.  
The control connection screw size is M3.

### 3.3.5 Replace Terminal Compartment Cover

To replace the cover, follow the steps detailed in **Section 3.3.1, Remove Separate Terminal Chamber (STC) Cover** in reverse order.

---

**NOTE:**

Clean electrical enclosure threads thoroughly and lightly grease with a dielectric grease before closing.

---

### 3.3.6 External Earth/Ground Connections

External connection points are provided on the actuator motor and main gear housing for attaching earth/ground in accordance with local electric codes for installation cables.

Connect the external earth/ground connection as follows:

1. Using a 1/4 inch (6mm) slotted tip screwdriver back out the 5/16 inch (8mm) set screw.
2. Connect 14 AWG or larger earth/ground wire; tighten setscrew.

Figure 3-5 Earth/Ground Connection



## 3.4 Display Backup Module (DBM) – Optional

The DBM is a battery pack containing two 9V Lithium battery clips. This battery pack provides power to the electronics, but does not power the motor control circuits or the 24 Vdc power supply. When using this option, all latching-type relays on the standard unit and the Auxiliary Relay Module (ARM) will continue to operate. This option permits testing or setting up the actuator without applying main power.

The DBM can be provided as an option with the TEC2 or it can be purchased later. If purchased separate, install as follows. If provided with the TEC2, proceed with Step No. 2 to activate.

1. Mount the DBM under the Auxiliary Control Module (ACM) on the cover plate and connect to the Central Control Module (CCM) via a 3-wire cable.
2. Enable battery backup in the setup menu, refer to **Section 5, Customized Actuator Settings**.

**NOTE:**

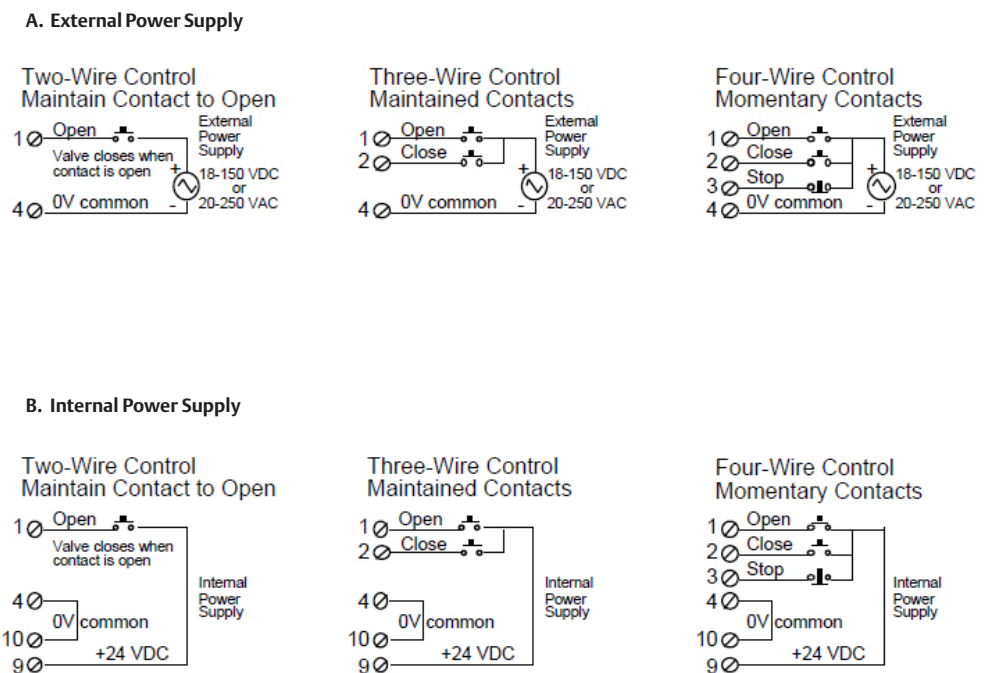
The battery should not be enabled until the unit is field commissioned and ready for power to be applied.

The battery can only be replaced with an Ultralife U9VL 9V battery. To prevent losing the clock settings, install one new battery before removing one old one. Two batteries can be installed for extended life.

### 3.5 Discrete Controlled Inputs

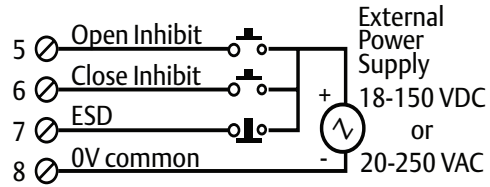
The actuator can be controlled by discrete inputs: two-wire control, three-wire control, four-wire valve control. Connect the power for these discrete inputs as detailed in **Figure 3-6, Control Input Wiring** for external and internal power source. **Figure 3-7** details connections for Inhibit and ESD wiring. See **Section 3.3, Electrical Connections** for general electrical connection requirements.

**Figure 3-6 Control Input Wiring**

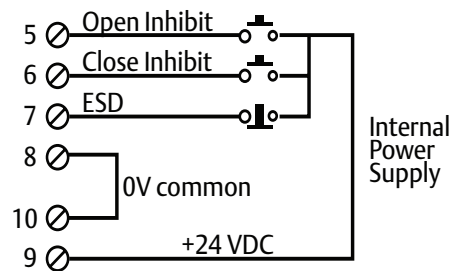


**Figure 3-7 Inhibit and ESD Wiring**

**A. External Power Supply**



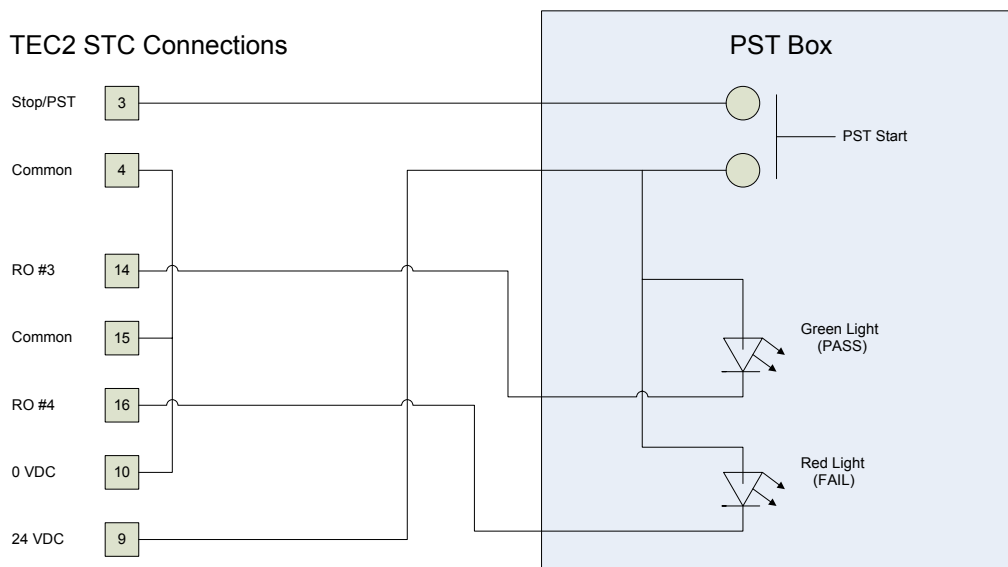
**B. Internal Power Supply**



**NOTE:**

See **Section 3.6.2, Analog Controlled - Power Supply Connections** for 3 wire analog.

**Figure 3-8 TEC2 Partial Stroke Test (PST) Wiring Diagram**



## 3.6 Auxiliary Control Module (ACM) – Optional

The ACM is an optional module used to expand the functionality of the TEC2 Actuator. There are several versions of the ACM available: Futronic, Controlinc, and Auxiliary Relay Module (ARM). The Futronic ACM may be used alone or with the ARM stacked on top. The Controlinc ACM is used with a Communication Adapter Module (CAM). The ARM may also be installed alone. Each ACM can be supplied with the TEC2 Actuator or provided later as an upgrade.

The ACM has two 4-20mA analog input and two 4-20mA analog outputs. Only one of the analog input could control at any time. Both of these inputs are configurable. Analog Output #1 is position feedback and Analog Output # 2 is torque. By default, the two analog outputs are used for valve position and torque feedback.

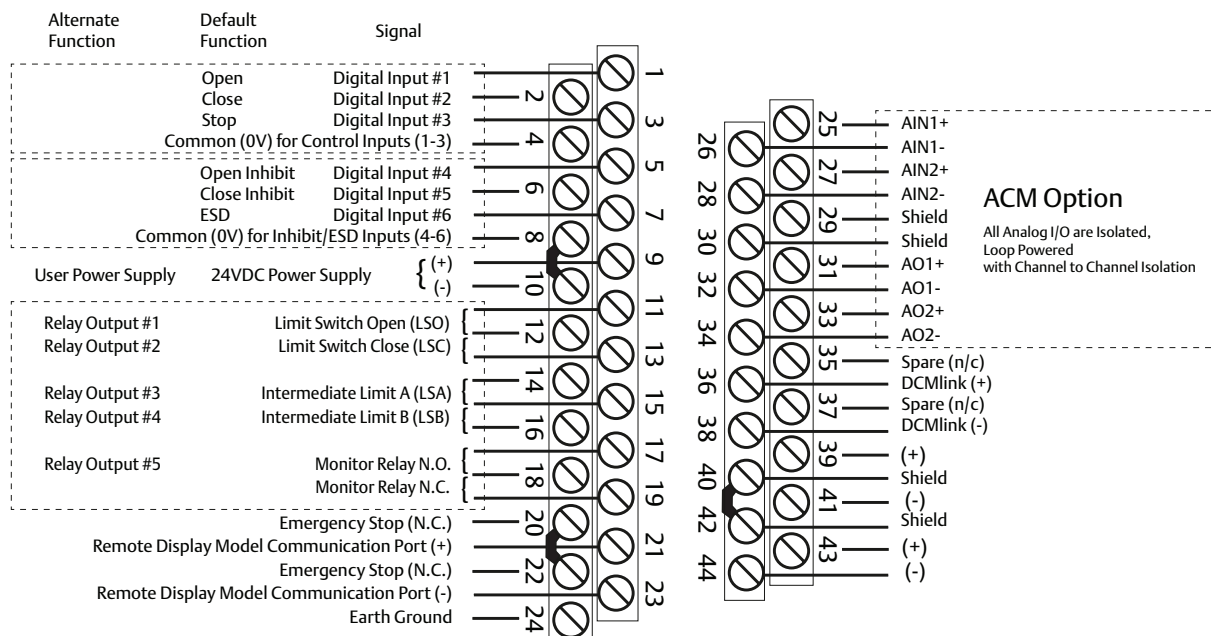
The Controlinc ACM has two analog inputs and two analog outputs. The analog inputs and output may be used for generic data acquisition and control by the network host or for the closed loop control. The ACM is normally configured to allow the host to control the analog output; the host can write a 12-bit value between 0-4095 via the network to generate a 4-20mA output.

### 3.6.1 Wiring the ACM

ACM modules may be installed only by factory-trained technicians. Only one Futronic or Controlinc ACM can be installed at a time inside the round cover nearest the display end. The Futronic or Controlinc ACM connects to the Central Control Module (CCM) for logic control functions and to the Separate Terminal Chamber (STC) for user wiring connections.

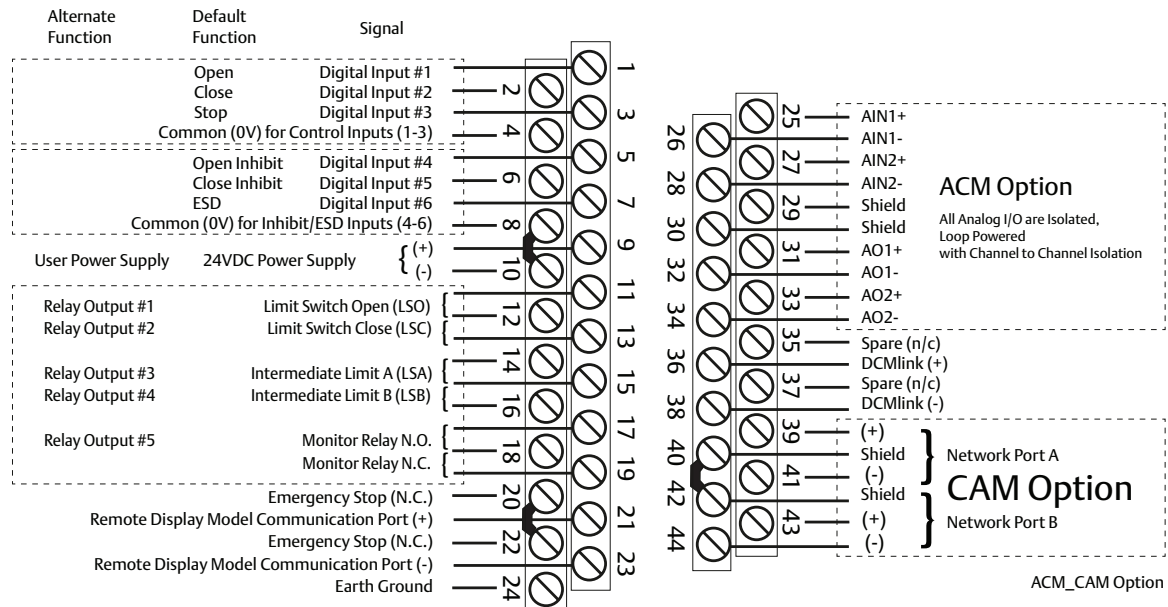
To wire the ACM, connect the wires in accordance with **Figure 3-9** and **Figure 3-10** as applicable. See **Section 3.3, Electrical Connections** for general electrical connection requirements.

**Figure 3-9 ACM Wiring Connections - ACM (Analog Control Module)**



The ARM can be installed with the Futronic ACM by stacking it on top of the Futronic ACM and connecting to the STC. See **Section 3.7, Auxiliary Relay Module (ARM) Wiring**.

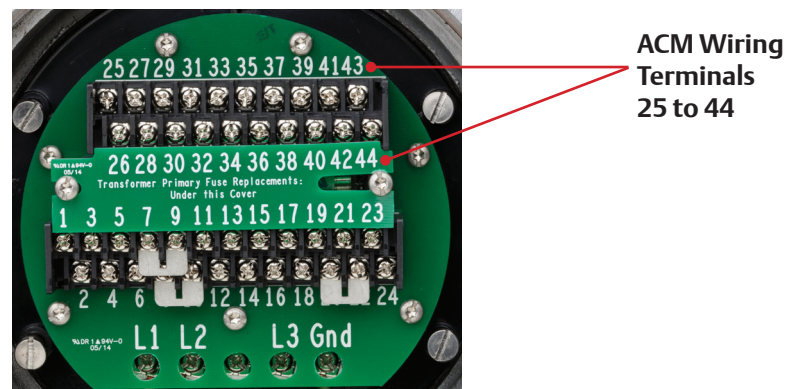
**Figure 3-10 ACM Installation Connections - ACM (Network Control Module)**



**Notes:**

1. All digital inputs have an input voltage range of 18-150 Vdc or 20-250 Vac.
2. All digital relay outputs are rated for 5 A @ 30 Vdc or 5 A @ 250 Vac Resistive, 2 A Inductive load.
3. Jumpers can be added between Terminals 8 and 10, Terminals 32 and 34, Terminals 36 and 38, and Terminals 40 and 42 but are not required.
4. Emergency Stop requires jumper (between Terminals 20 and 22) or normally closed contacts (actuator stops when contacts open).
5. Remote display communication port is RS-485.
6. If bare wires (without terminals) are connected, remove a maximum of 1/4 inch (6 mm) insulation.

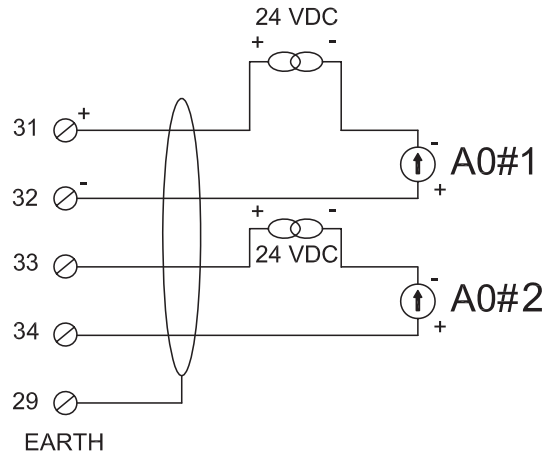
**Figure 3-11 ACM Wiring Connections**



### 3.6.2 Analog Controlled – Power Supply Connections

The power sources for analog controlled inputs/outputs are either internal or external. Connect the power supplies as shown in **Figure 3-12** through **Figure 3-17**.

**Figure 3-12 ACM – Analog Output with External Power Supply**



**Figure 3-13 ACM - Analog Output with Internal Power Supply**

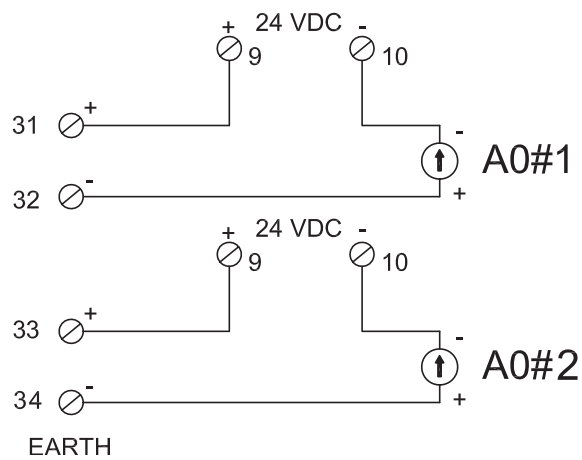


Figure 3-14 ACM – Analog Input with External Power Supply

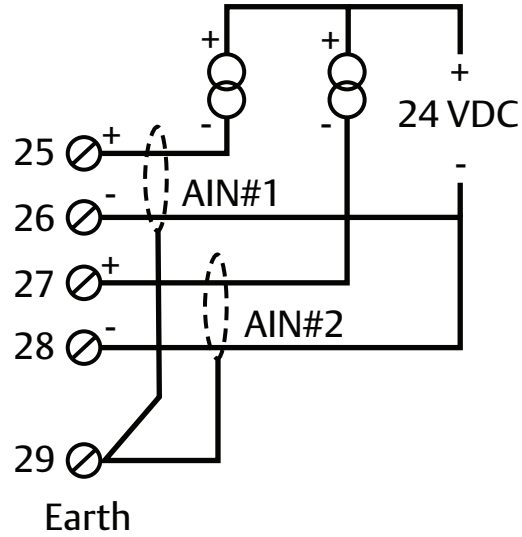


Figure 3-15 ACM– Analog Input with Internal Power Supply

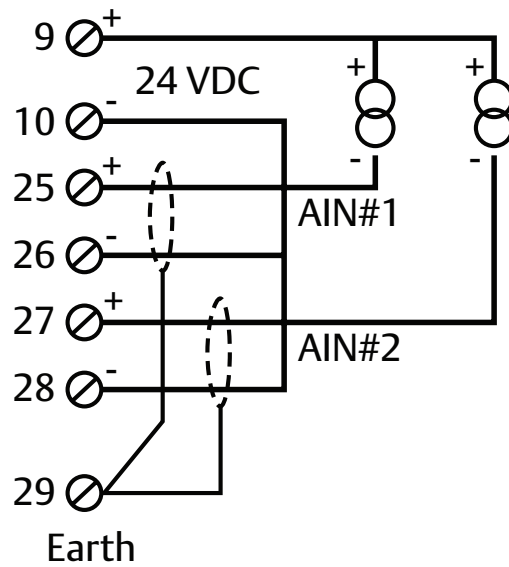




Figure 3-16 Futronic – 3 Wire Analog Control with External Power Supply

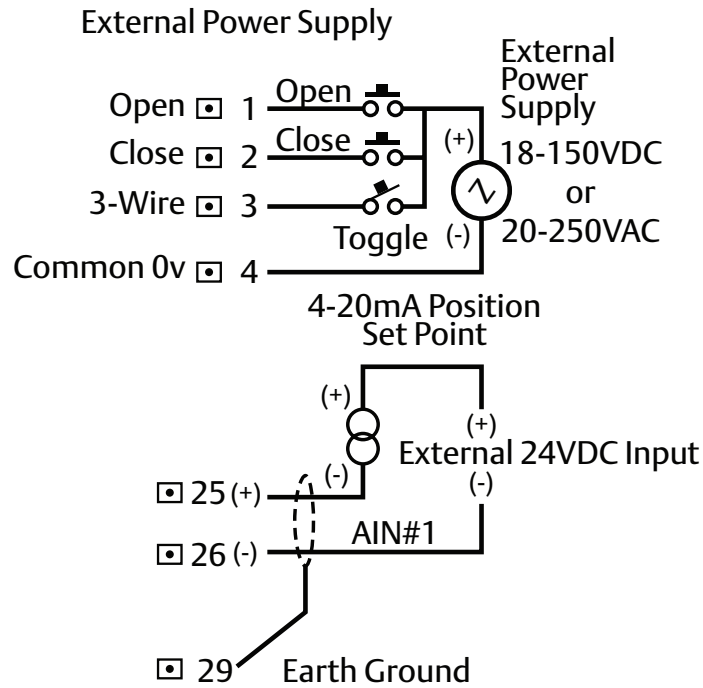
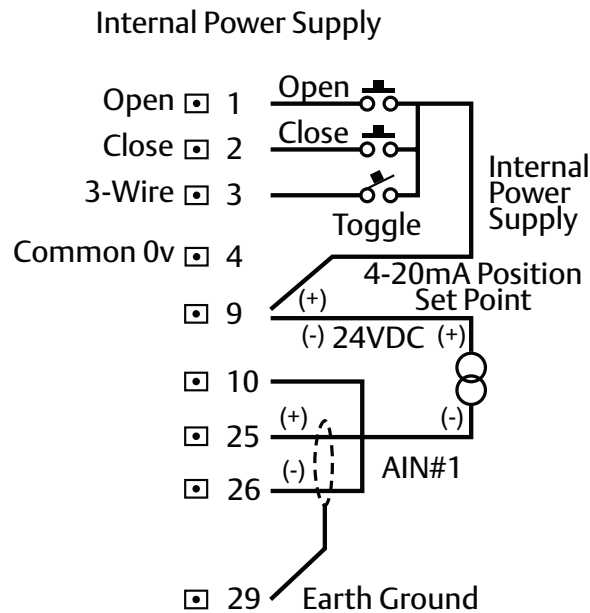


Figure 3-17 Futronic – 3 Wire Analog Control with Internal Power Supply



### 3.6.3 Network Controlled

For the actuator to be network controlled, a Controlinc ACM and a Communication Adapter Module (CAM) must be installed. Each CAM is required for a specific protocol and network topology, and enables the network capability. To install the Controlinc ACM see **Section 3.6.1, Wiring the ACM**.

---

#### NOTE:

Factory personnel must install the ACM and CAM. These modules (CAMs) may be installed in the field only by factory-trained technicians using a special passcode to enter the “**FACTORY SETUP**” mode.

---

Connect the actuators as shown in **Table 3-1** for RS-485 redundant bus or E>Net networks. If another protocol is selected then refer to the wiring diagram supplied with the actuator for connections.

---

#### NOTE:

If E>Net network topology is specified, insert a jumper between Terminals 40 and 42 to connect the network cable shield throughout the network and connect a single point earth/ground elsewhere.

---

See **Section 3.3, Electrical Connections** for general electrical connection requirements.

**Table 3-1. Connecting Actuator A to Actuator B**

Terminal Block	Function
39	Data Port A (+)
41	Data Port A (-)
40	Shield
43	Data Port B (+)
44	Data Port B (-)
42	Shield

## 3.7 Auxiliary Relay Module (ARM) Wiring

The ARM can be used with the Futronic ACM or standalone. Only factory-trained technicians may install the ARM.

Connect the ARM within the controller in accordance with **Table 3-2**. See **Section 3.3, Electrical Connections** for general electrical connection requirements.

**Table 3-2. ARM Wiring Connections**

Terminal Block	Function	Relay Type
39	Relay Output #9	Latching NO or NC
40	Common	
41	Relay Output #10	Latching NO or NC
42	Relay Output #11	Latching NO or NC
43	Common	
44	Relay Output #12	Latching NO or NC

**Figure 3-18 ARM Wiring Diagram**

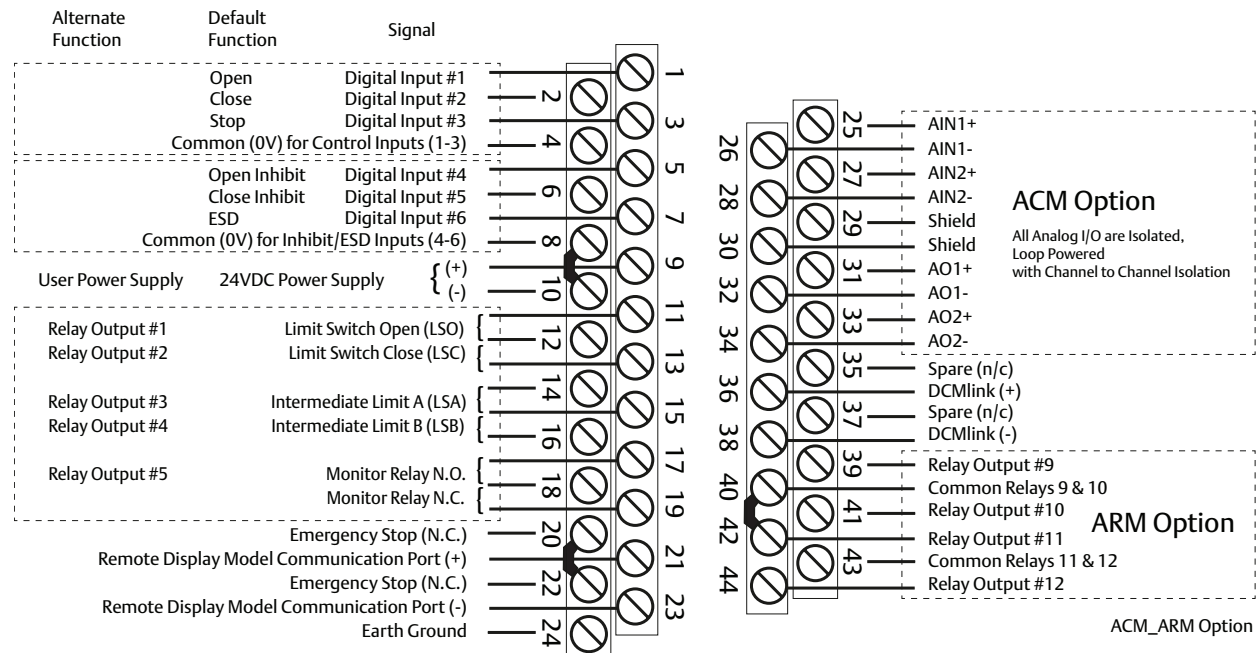
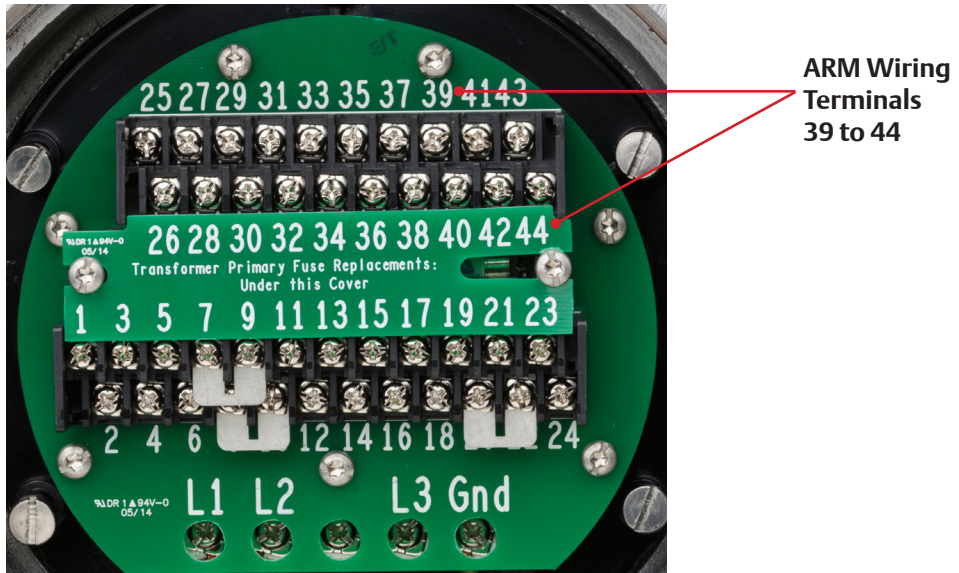


Figure 3-19 ARM Wiring Connections



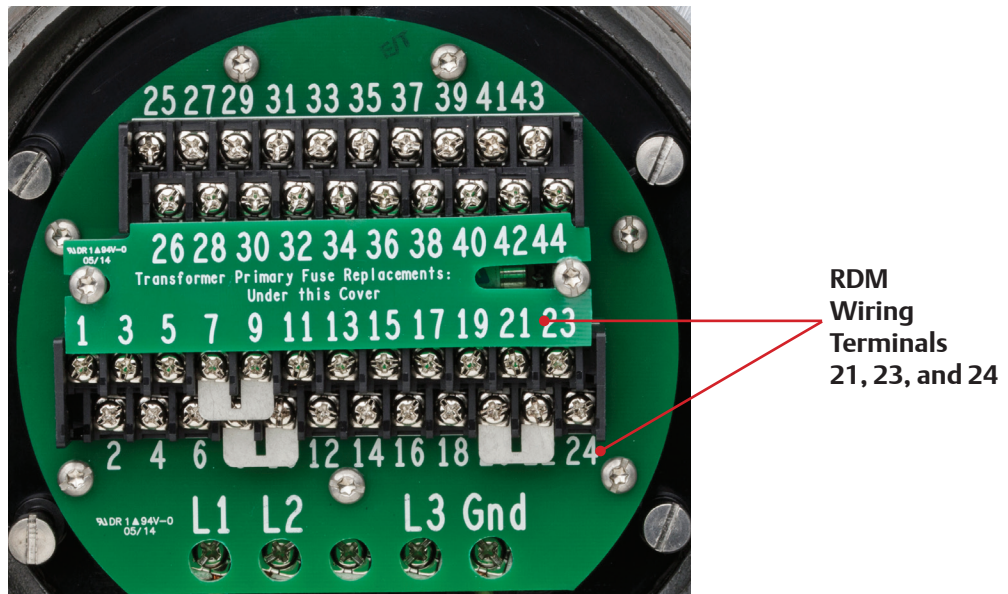
## 3.8 Remote Display Module (RDM) Connection to the Actuator – Optional

Connect the RDM to the actuator as shown in **Figure 3-20** and in accordance with **Section 3.8.1, 24 Vdc Power Source**, or **Section 3.8.2, 115/230 Vac Power Source**, depending on the power source. Each RDM can be powered from the actuator, or it can be powered from an external source. If more than one RDM is used, one can receive power from the actuator and the other can receive power from an external source. See **Section 3.3, Electrical Connections** for general electrical connection requirements.

**NOTE:**

If RDM 1 or 2 is enabled and not connected, the actuator will be in stop mode and cannot be operated until RDM is connected or disabled.

**Figure 3-20** Connecting RDM Cables to the STC



### 3.8.1 24 Vdc Power Source

If the RDM is to receive power from the actuator, connect cable type Belden 8723 or equivalent as detailed in **Table 3-3**. The cable distance is limited to 1,200 feet (366 meters).

---

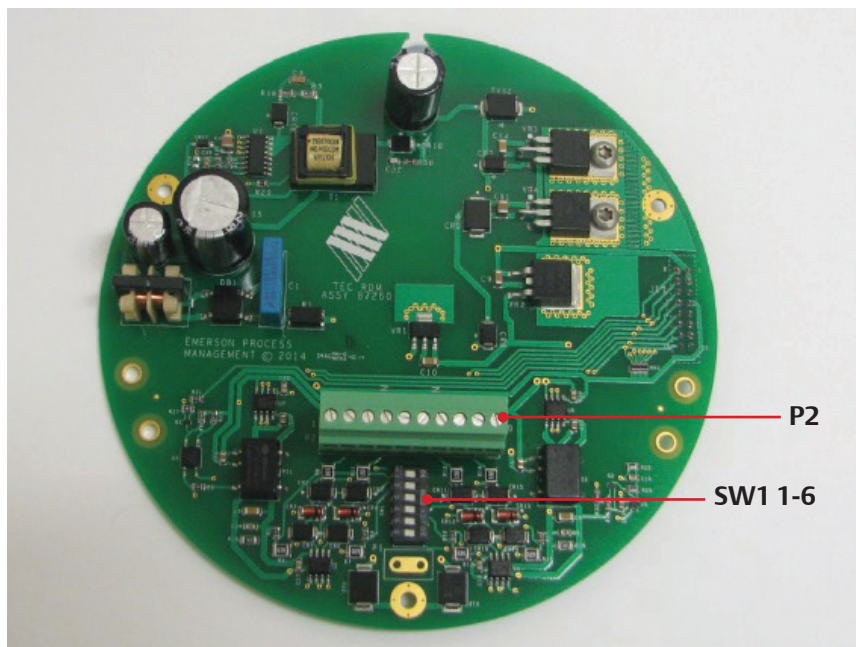
**NOTE:**

By using two cables, Belden 8719, or equivalent for power and Belden 9841 or equivalent for RS-485 communication, the distance limitation is increased to 4,000 feet (1,200 meters).

---

---

**Figure 3-21 RDM Interface Module (Support Both 24V DC and AC)**



**Table 3-3. RDM Connections with Internal Power Source (24VDC)**

RDM Interface Module Connector P2	Function	TEC2 STC Terminals
P2-10 (24V +)	24 Vdc(+)	9
P2-9 (24V -)	0V Common	10
P2-3 (CHA -)	RS-485 (-)	23
P2-5 (CHA +)	RS-485 (+)	21
P2-4 (CHA N)	Shield	24

### 3.8.2 115/230 Vac Power Source

If the RDM is receiving power from an external source, connect cable type Belden 9841 or equivalent as detailed in **Table 3-4**.

**Table 3-4. Connections with External Power Source (External AC)**

RDM Interface Module Connector P2	Function	TEC2 STC Terminals
P2-1 (AC +)	115/230 Vac 50/60 Hz (+)	-
P2-2 (AC -)	0V Common	-
P2-3 (CHA +)	RS-485 (+)	21
P2-5 (CHA N)	RS-485 (-)	23
P2-4 (CHA -)	Shield	24

### 3.8.3 Two RDMs (One 24 Vdc and One 115/208/220/230 Vac Power Source)

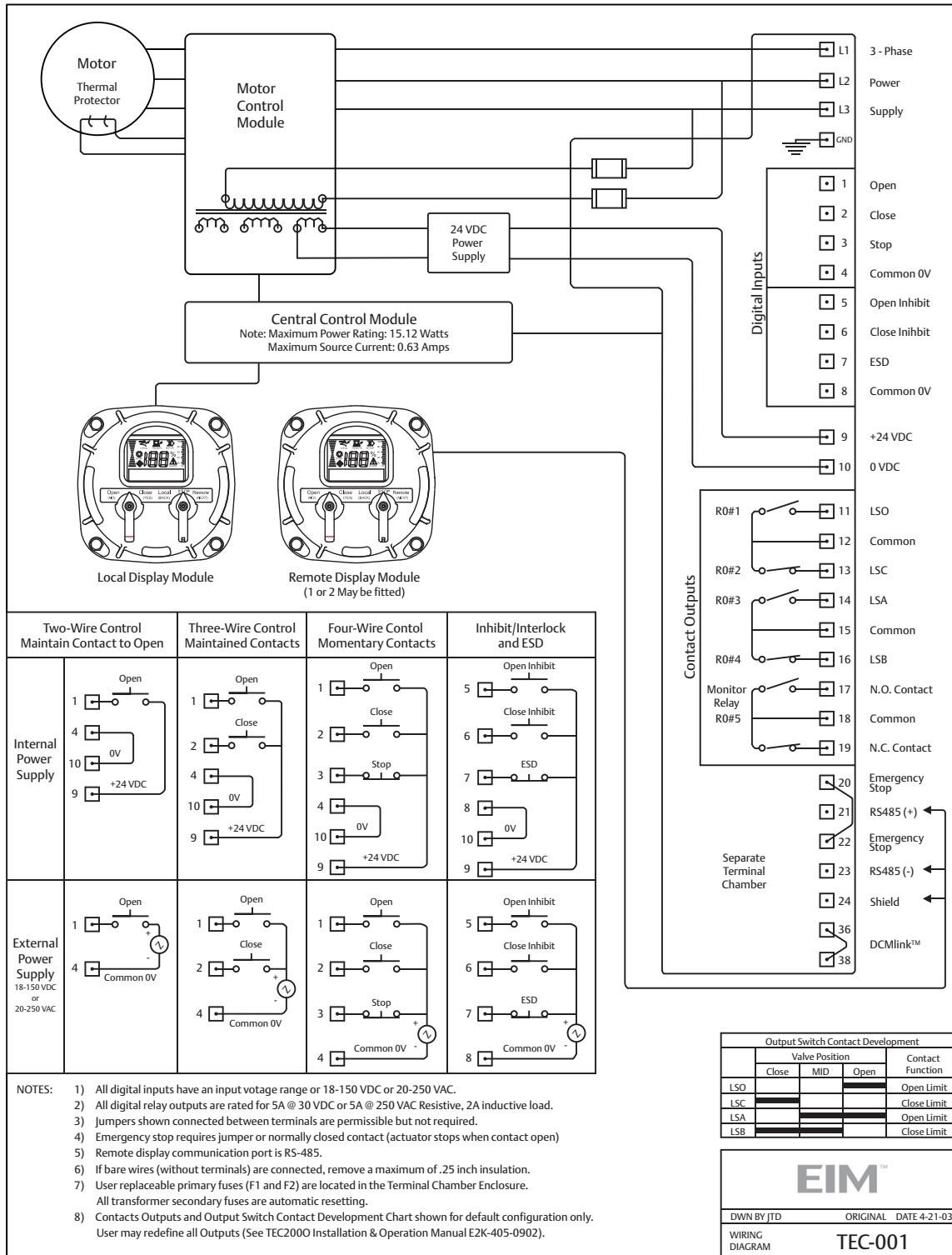
To use two RDMs, one can receive 24V DC power from the actuator and the other has to get power from an external AC source, 115/208/220/230 Vac.

### 3.8.4 RDM Connections and Dip Switch Settings

**Table 3-5. Dip Switch (SW5 and SW6) Settings**

	RDM1	RDM2	LDM
SW1-5	On	Off	Off
SW1-6	Off	On	Off

Figure 3-22 TEC - 001 Wiring Diagram



**NOTE:**

The Local Display Module (LDM) is a part of the actuator and is powered internally by a low voltage DC. The Remote Display Module (RDM) is powered by two options, either 24VDC or 90-250VAC 50/60Hz.



## Section 4: Operation

Figure 4-1 TEC2 Controller



### 4.1 Local Display Module

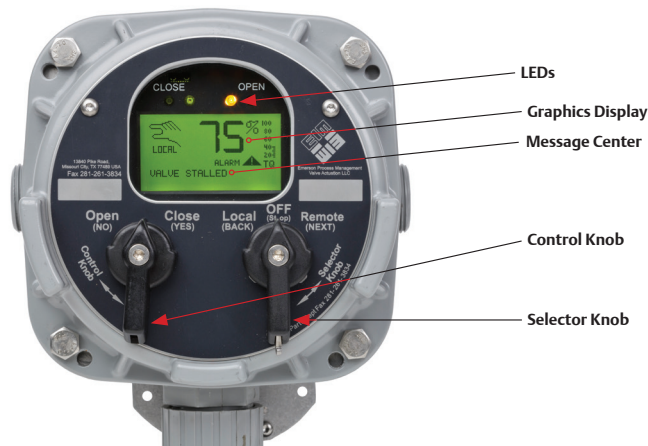
#### *Display Module with Bluetooth® - Model 87340*

See Appendix for Specifications.

The Local Display module consists of the following as shown in **Figure 4-2**:

- Graphics Display
- Message Center
- Control Knob and Selector Knob
- Three LEDs

Figure 4-2 Local Display Module (LDM)



#### 4.1.1 Graphics Display and Message Center

The graphics display shows the mode of operation, valve status, position, torque, and alarm symbols. The message center displays actuator setup selections, data entry feedback, and alarm messages. When no alarms are active and the valve is not moving or is not at either limit, the message center will be blank.

#### 4.1.2 Control Knob and Selector Knob

The control knob performs normal Open/Stop/Close function in the local control mode and YES/NO function in the “**MONITOR/SETUP**” mode as detailed in **Table 4-1**.

The NO selection increments the displayed value but does not decrement. To decrement continuously hold the NO position until the highest value is reached. The display value will then start at the lowest value and increment from there. If the control knob is held in the NO position for more than 2 seconds the incrementing rate will increase from 0.5 seconds per new value to 0.1 seconds per value.

The selector knob performs normal selector switch Local/Stop/Remote function and alternate Next/Back display function in the “**MONITOR/SETUP**” mode as detailed in **Table 4-1**.

The NEXT and BACK selections are used strictly for cycling through the SETUP displays to locate the desired display or to exit the “**SETUP**” mode.

**Table 4-1. LDM Rotating Knobs**

Knob	Rotation Direction	Function	Result
Control	Spring return to center	Neutral Position	Completes YES or NO entry cycle. Exception: when knob is held for continuous data entry updates.
	Clockwise (CLOSE)	YES	Accepts the displayed question or data entry. Advances to the next display. Exception: when knob is held for continuous data entry updates.
	Counterclockwise (OPEN)	NO	Rejects displayed question or data. Increments to the next data value or display. Exception: when knob is held for continuous data entry updates.
Selector	STOP	Neutral Position	Sets up entry, completes NEXT or BACK entry cycle. See Note below
	Clockwise (REMOTE)	NEXT	Advances to the next display
	Counterclockwise (LOCAL)	BACK	Returns to the previous display

**NOTE:**

If the selector knob remains in either NEXT or BACK position, the display will scroll.

#### 4.1.3 LEDs

There are three LEDs on the LDM:

- Red
- Green
- Yellow

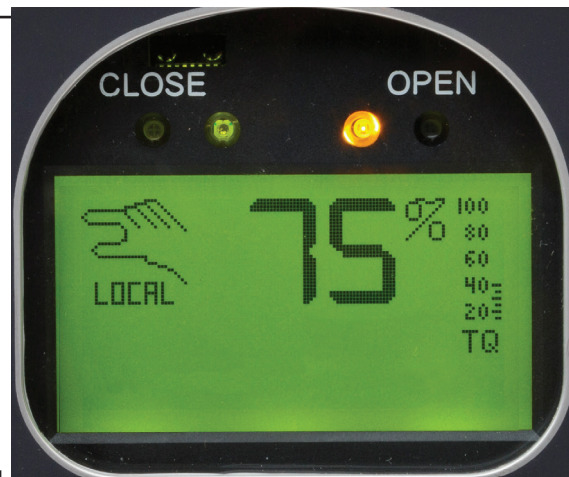
The default function of these LEDs is detailed in **Table 4-2**.

See **Section 5.5.2, Valve Control Setup** to reverse Red to indicate closed/closing and Green to indicate opened/opening.

### 4.1.4 Normal Display Function






**Figure 4-3** details the display during normal function. The bar graphs, position digits, icons, and LEDs indicate normal activity, i.e., the valve opening, closing, or stopping in mid-travel. The message center remains blank until alarms are active or the valve is opening, closing, full open, or full close. **Table 4-2** details various normal activities and how each is displayed.

**Figure 4-3 Normal Display**



The valve has stopped and is 75% opened. The yellow LED is ON and the message center is clear.

**Table 4-2. Normal Display Functions**

Valve Activity	Message Center Top Line	Display Functions (LEDs)			Position Bar Graph	Percent Open "XX%"
		Yellow	Red	Green		
Fully closed	FULL CLOSE	OFF	OFF	ON		0%
Opening	OPENING	OFF	Blinking	OFF	Flashing in the Open direction 	Increments
Stopped	Cleared	ON	OFF	OFF	STOP Icon is Displayed 	
					Shows relative position 	% open
Fully opened	FULL OPEN	OFF	ON	OFF		100%
Closing	CLOSING	OFF	OFF	Blinking	Flashing in the Close direction 	Decrements
Alarm	Alarm Type Displayed -Bottom Line	Blinking	OFF	OFF	Alarm Icon 	

## 4.2 Remote Display Module (RDM)

### *Display Module with Bluetooth® - Model 87340*

**See Appendix for Specifications.**

The RDM performs the same functions as the LDM.

---

**NOTE:**

If the RDM does not receive communication messages from the Central Control Module (CCM) within 5 seconds after power is applied, the RDM will display the flashing message “**CCM LINK FAILED**” and all three LEDs will blink. This will also occur if communication is lost for 5 seconds or more.

If RDM 1 or 2 is enabled and not connected, the actuator will be in stop mode and cannot be operated until RDM is connected or disabled.

---

#### 4.2.1 RDM Operation with LDM

Two RDMs and an LDM can be connected to one actuator. The operation priority is detailed in **Table 4-3**.

**Table 4-3. RDM and LDM Operation Priority**

Mode of Operation	LDM, RDM #1, RDM #2 and Selector Switch Position
STOP	At least one module must have the selector switch in the STOP position.
LOCAL	At least one module must have the selector switch in the LOCAL position and none have the selector switch in the STOP position.
REMOTE	All modules must have the selector switch in the REMOTE position.

## 4.3 Initializing the Actuator

---

**NOTE:**

The TEC2 has automatic phase correction.

---

### 4.3.1 Setting Position Limits

Limits must be set before operating. The actuator will not operate until limits are set.

---

**NOTE:**

A passcode is not needed for the initial position limit settings. However, any limit setting changes required after initialization requires a passcode and are changed via the “CHANGE SETTINGS” mode. See **Section 5.5.3, Set Valve Travel Limits**.

---

**⚠ CAUTION:**

**It is recommended that the final valve position be set using the handwheel while setting the limits to prevent valve damage.**

---

There are two different routines for setting limits. Initial limit settings can be set as described in **Section 2, Quick Start**. Limit settings can be changed as described in **Section 5.5.3, Set Valve Travel Limits**.

Once the limits have been set, check the settings as follows.

For Electrical Operation:

1. Run actuator electrically to verify correct operation.

For Manual Operation:

1. Move the valve in the close direction. The Red LED should go off and the Green LED should blink within one handwheel turn.
2. Move the valve in the open direction. The Green LED should go off and the Red LED should be blinking within one handwheel turn.

The actuator will operate in the normal LOCAL and REMOTE modes.

Exit “SETUP” mode.

1. Rotate the selector knob to **NEXT** to cycle through the displays until “EXIT?” is displayed.
2. Rotate the control knob to **YES**.

### 4.3.2 View Existing Settings

Unless otherwise specified at the time the order is placed, the TEC2 actuator is shipped with the following default configuration settings.

**Table 4-4. Default Configuration Settings**

Basic Actuator Functions

Valve Control	Discrete Inputs	Discrete Outputs		Inhibit and ESD
		(Relays 1 thru 5)	(ARM Relays 9 thru 12)	
Mode = 3 Wire	DI#1= Active on CLOSED contact	RO#1= LSO	RO#9 = Lost Power Alarm	Open Inhibit = OFF
Close Direction = (Gearing Dependent)	DI#2= Active on CLOSED contact	RO#1= N.O.	RO#9 = N.O.	Close Inhibit = OFF
Seat = Position	DI#3= Active on OPEN contact	RO#1= Continuous	RO#9 = Flash	Local ESD = OFF
Close Torque = 50%	DI#4= Active on CLOSED contact	RO#2= LSC	RO#10 = Motor Overload Alarm	Remote ESD = OFF
Open Torque = 50%	DI#5= Active on CLOSED contact	RO#2= N.O.	RO#10 = N.O.	Lost Com ESD = OFF
Local Control = Maintain	DI#6= Active on OPEN contact	RO#2= Continuous	RO#10 = Flash	Stayput on ESD = ON
Remote Control = Maintain		RO#3= LSO	RO#11 = Lost Phase Alarm	* ESD Override on Thermal = OFF
Torque Retry = OFF		RO#3= N.O.	RO#11 = N.O.	ESD Override on Local = OFF
Remote Display 1 = OFF		RO#3= Continuous	RO#11 = Flash	ESD Override on Stop = OFF
Remote Display 2 = OFF		RO#4= LSC	RO#12 = Over Torque Alarm	ESD Override on Inhibit = OFF
Close LED = Green Open LED = Red		RO#4= N.O.	RO#12 = N.O.	ESD Override on Torque = OFF
Low Battery Alarm = OFF		RO#4= Continuous	RO#12 = Flash	ESD Delay 0.0 Seconds
Valve Stall Delay Time = 8 Sec		RO#5= MONITOR		Go to _% Open on ESD = 0
Retain Setpoint = OFF		RO#5= Continuous		
		LSA Position = 25%		
		LSB Position = 75%		

\* Overriding the thermal motor protection will invalidate the hazardous area certification.

Two-Speed Timer Default Configuration

Close	Open	Anti-Water Hammer
Mode = OFF	Mode = OFF	Mode = OFF
Start Position = 30%	Start Position = 70%	Start Position = 10%
Stop Position = 1%	Stop Position = 99%	
Pulse ON time = 3.5 Sec	Pulse ON time = 3.5 Sec	Pulse ON time = 3.5 Sec
Pulse OFF time = 5.0 Sec	Pulse OFF time = 5.0 Sec	Pulse OFF time = 5.0 Sec

Auxiliary Control Module (ACM) Default Configuration

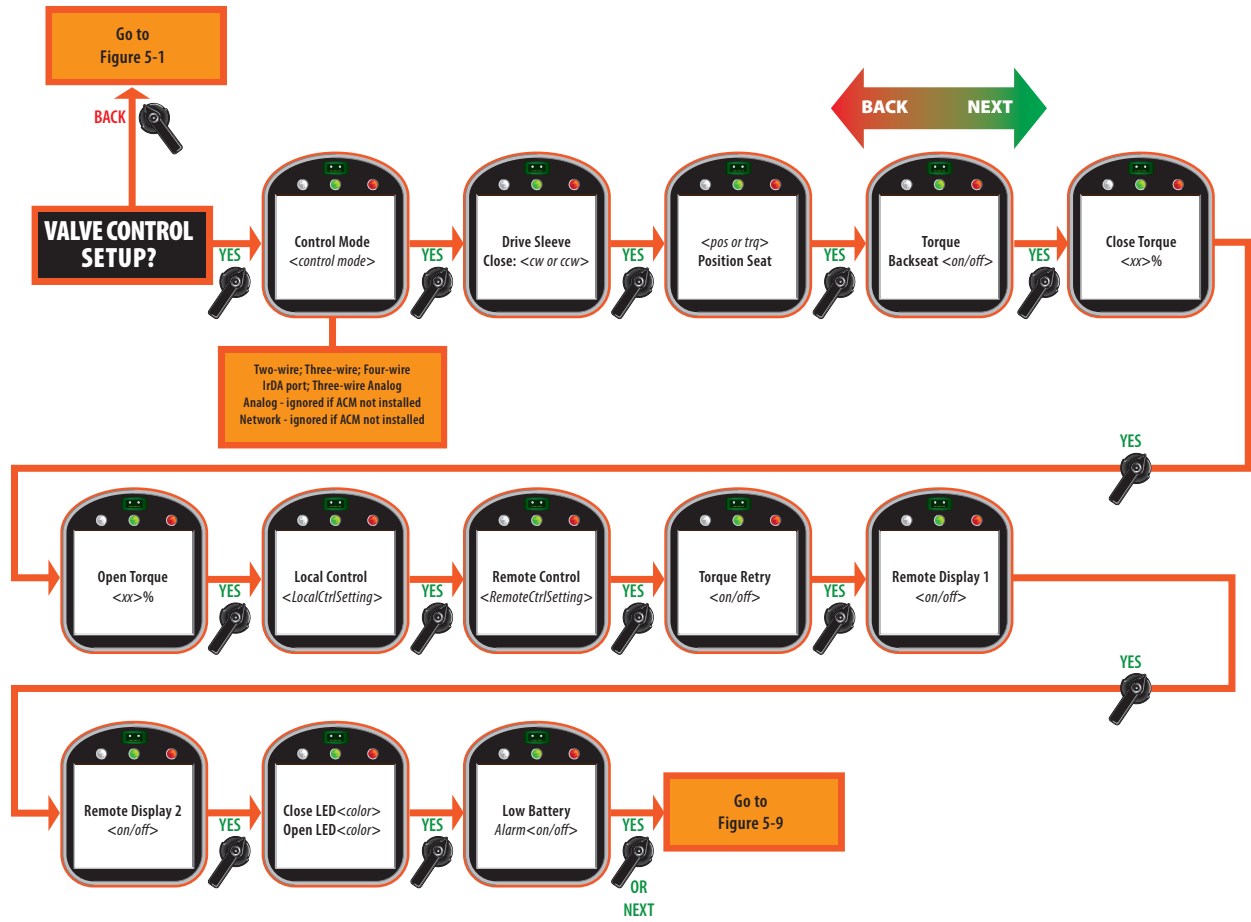
Analog Control - Futronic	Network Control - Controlinc
Control Bandwidth = 2.0%	Network Node Address = 001
Speed Bandwidth = 5.0%	Response Delay Time = 8ms
Delay Time = 1 Second	Parity = NONE
Input Polarity CLOSE = 4mA	Analog I/O Scale 0 - 4095
Output Polarity CLOSE = 4mA	Write Protect = NO
STAYPUT on lost signal	

1. Enter “**SETUP**” mode as detailed in **Step No 2** of **Section 2, Quick Start**.
2. Place the selector knob in the NEXT position to advance through each display until “**DISPLAY SETTINGS?**” is displayed.
3. Rotate the control knob to **YES**.
4. Scan through each display selecting **NO** or **YES** and **BACK** or **NEXT** as needed to review the current settings. See **Figure 4-4**.

**NOTE:**

The “**DISPLAY SETTINGS?**” mode can be accessed without entering a passcode; however no changes can be made to the settings in this mode. To make any changes see **Section 5, Customizing Actuator Settings**.

Figure 4-4 Display Settings





## 4.4 Local Control Operation

To locally control the actuator via the LDM or the RDM:

1. Exit “**SETUP**” mode if applicable.
2. Place the selector knob in the LOCAL position.

---

### NOTE:

The actuator is shipped configured for inching mode unless specified at the time order is placed; i.e. the actuator is shipped in the “Maintained” mode.

---

### Local Maintained – Inching Mode

3. Place the control knob in either the OPEN or CLOSE position and continue to hold. After 0.5 seconds the actuator will move in the open or close direction.
4. Release the knob to stop the actuator movement. The knob will return to the neutral position.

### Local Momentary Mode – Seal-ins Active

3. Place the control knob in either the OPEN or CLOSE position. Momentarily hold for 0.5 seconds and release. The actuator will move in the open or close direction to the end of travel.
4. To stop the actuator movement:
  - Place the selector knob in the STOP position.
  - OR
  - Place the control knob in the opposite direction of the current movement for less than 1.0 second.

---

### NOTE:

If the control knob is held in the opposite direction for more than 1.0 second, the actuator will reverse direction after stopping for approximately 0.5 seconds to allow instant reversing without valve plugging or causing high stresses and damage to the actuator.

---

## 4.5 Remote/Auto Control Operation

The actuator is shipped configured for “four-wire control” unless otherwise specified at order placement. There are additional remote control modes that can be selected via the “**SETUP**” mode.

---

### NOTE:

See **Table 4.4** for defaults.

---

- Two-wire control
- Three-wire control
- IrDA port
- Three-wire analog
- Analog
- Network

For installation details, see **Section 3.5, Discrete Controlled Inputs**.

To control the actuator via discrete inputs:

1. Enter “**SETUP**” mode. See **Section 5.1, Entering Setup Mode**.
2. Use the selector knob (**NEXT/BACK**) to select “**CONTROL MODE**” under “**VALVE CONTROL SETUP?**”
3. Use the control knob (**NO**) to select the desired control mode. See **Section 5.5.2, Valve Control Setup**.
4. Exit “**SETUP**” mode and place selector knob in the REMOTE position.

### Remote Maintained – Inching Mode

5. Apply the control signal and maintain. After 0.5 seconds the actuator will move in the open or close direction.
6. Eliminate the control signal to stop the actuator.

### Remote Momentary – Seal-ins Active

5. Momentarily pulse either OPEN or CLOSE control signal for 0.5 seconds minimum. The actuator will move in the open or close direction to the end of travel.
6. Momentarily pulse the remote stop signal to stop the actuator movement.

### Two-Wire Control

The two-wire control mode uses only one contact to control the valve. When the contact is closed, the valve opens, and when the contact is open, the valve closes. The contact open and close status can be reversed in the “**SETUP**” mode. See **Section 5.5.4, Discrete Input Setup**.

### Three-Wire Control

The three-wire control mode uses two maintained contacts to open or close the valve. This is an “inching” type mode. Remote seal-ins, “Momentary” mode, may be activated in the “**SETUP**” mode. If the three-wire control is used with the seal-ins activated, the valve cannot be stopped while being remotely controlled; the valve can only be stopped via the inhibit or emergency stop inputs.

### Four-Wire Control

The four-wire control mode uses three maintained contacts to open, close, or stop the valve. The default configuration sets the stop input to be active on open contact. The default configuration can be modified in the “**SETUP**” mode. See **Section 5.5.4, Discrete Input Setup**.

## Section 5: Customizing Actuator Settings

### 5.1 Entering Setup Mode

The “**SETUP**” mode must be entered to modify any configuration settings.

1. Place the selector knob in the **STOP** position. Setup may be performed at any one location; i.e. at the LDM or any RDM that is connected.

---

**NOTE:**

**STOP** button on the Clicker only stops a moving valve.

---

2. Rotate the control knob to **YES**, then **NO**, then **YES**, then **NO** in rapid succession and then release. “**SETUP**” icon will be displayed on the display module and “**SETUP?**” will be displayed on the message center.

---

**NOTE:**

Do not hold the knob in any one position longer than 0.5 seconds.

---

3. Rotate the control knob to **YES**. A series of questions will be displayed as detailed in **Figure 5-1**.

---

**NOTE:**

If the control knob is placed in the **NO** position or if **NEXT** or **BACK** is selected in lieu of **YES**, the display will return to the normal display mode.

---

4. Use the control knob to answer “**YES**” or “**NO**” to the displayed questions. Use the selector knob, **NEXT** and **BACK**, to advance through the setup selections.
5. When configuring is complete, advance to “**EXIT SETUP?**” Answer “**YES.**” The display will return to normal display model.

---

**NOTE:**

If a knob entry is not made within 120 seconds, the actuator will exit the “**SETUP**” mode and revert to the normal display.

---

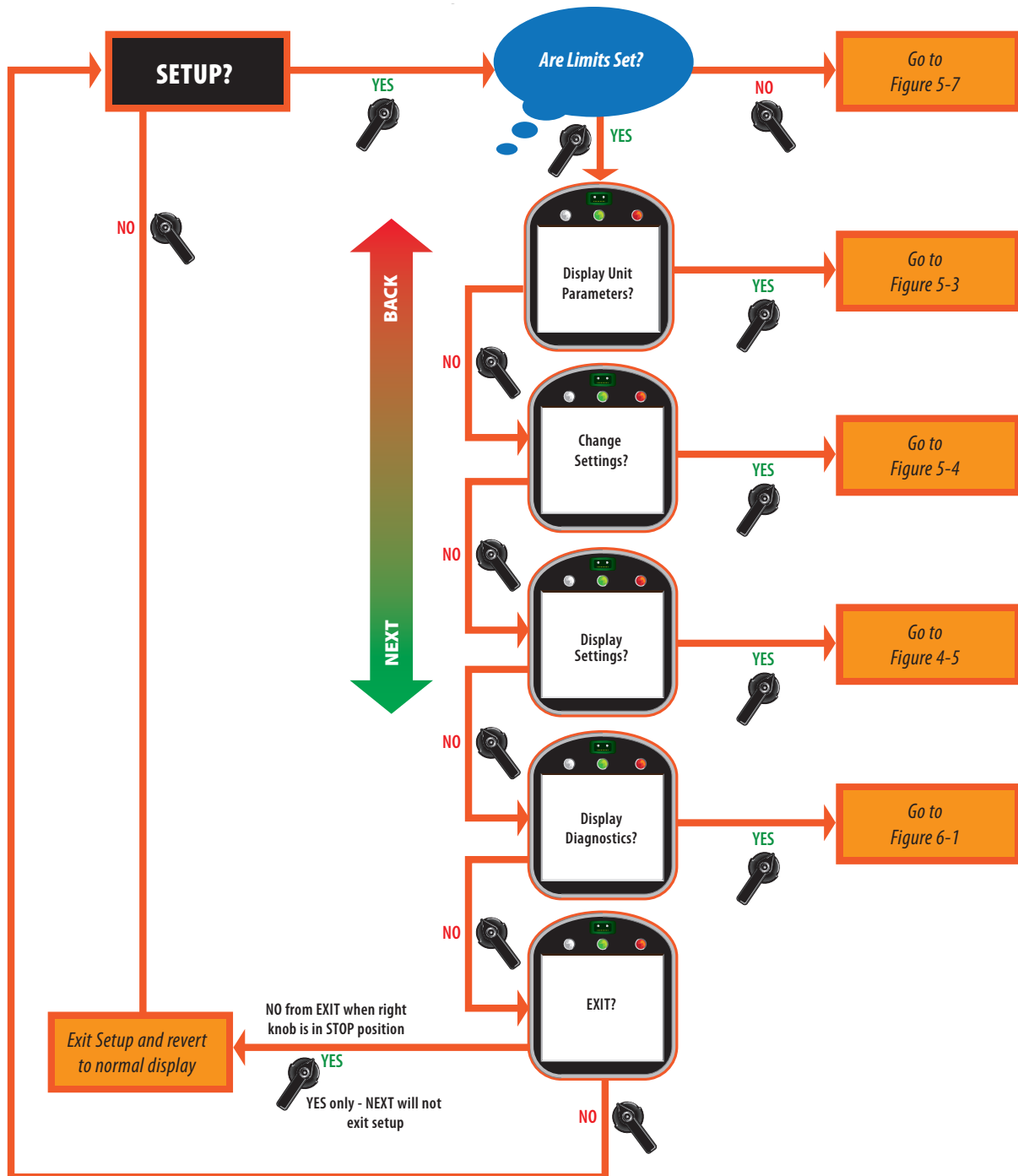
---

**NOTE:**

No Passcode is required for viewing any of the settings. Passcode will be needed for changing any of the parameters.

---

Figure 5-1 Setup



## 5.2 Setting Limits

After entering “**SETUP**” mode, the alarm message “**SET LIMITS BEFORE OPERATING**” will appear if limits have not been set. See **Section 4.3.1, Setting Position Limits**, to set the limits for the first time. If limits have been set, this display will be bypassed and “**CHANGE DISPLAY?**” will appear.

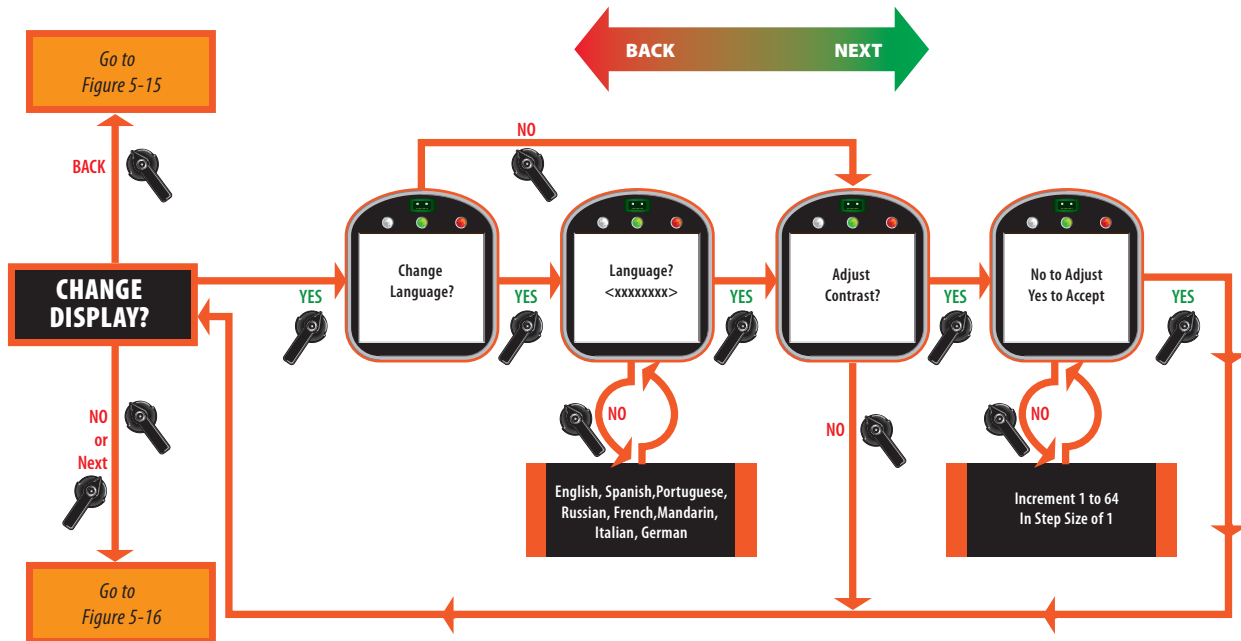
To modify previously set limits see **Section 5.5, Change Settings** and **Section 5.5.3, Set Valve Travel Limits**.

## 5.3 Changing Display

The language or the contrast can be changed as follows. A passcode is not required. See **Figure 5-2**.

1. At the “**CHANGE DISPLAY?**” prompt, answer “**YES.**” “**CHANGE LANGUAGE?**” will appear.
2. If English is the desired language, answer “**NO.**” “**ADJUST CONTRAST?**” will appear. Go to Step No. 4.
3. If English is not desired, answer “**YES**” to “**CHANGE LANGUAGE?**” and “**DISPLAY OTHER?**” will appear. The user may change any of the words being displayed on the message center by selecting an alternate language. “**ADJUST CONTRAST?**” will appear.
4. If contrast adjustment is needed, answer “**YES.**” Then select **NO** and hold until the desired contrast is reached. Select **YES.** “**CHANGE DISPLAY?**” appears.
5. Select **NO** to exit.

Figure 5-2 Change Display



## 5.4 Displaying Unit Parameters

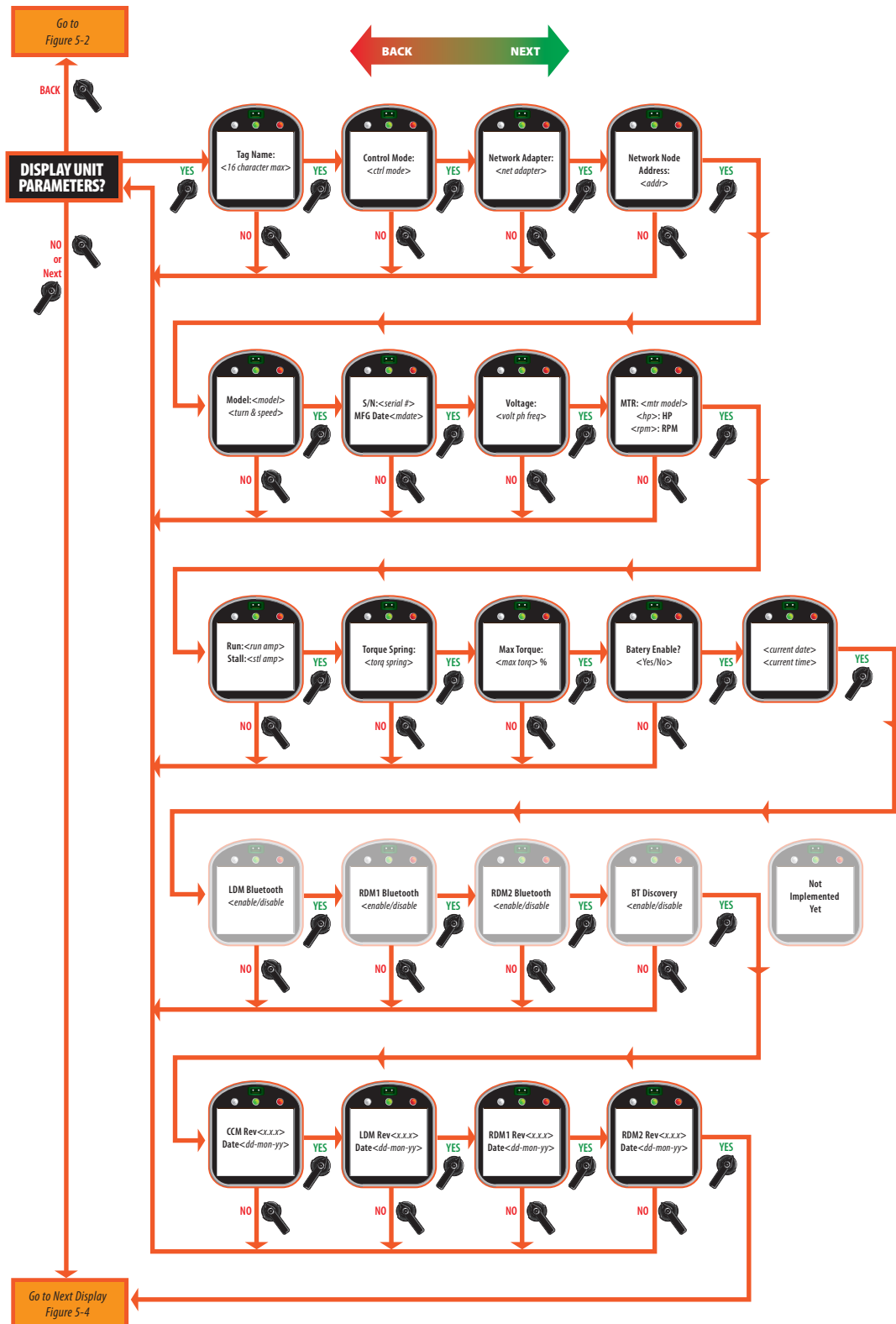
The user may view information on the actuator parameters as follows:

1. At the “**DISPLAY UNIT PARAMETERS?**” prompt answer **YES**.
2. Use the selector knob (**BACK/NEXT**) to view parameters as shown in **Figure 5-3**.

The tag name, method of control, and network address may be entered or changed via the “**Change Settings**” mode. See **Section 5.5, Change Settings**.

All other parameters viewed are factory setup and cannot be changed by the user.

Figure 5-3 Displaying Unit Parameters





## 5.5 Change Settings

1. Enter “**SETUP**” mode and use the selector knob (**NEXT**) to scroll to “**CHANGE SETTINGS?**”. Answer “**YES.**” See **Section 5.1, Entering Setup Mode.**
2. Enter passcode.

---

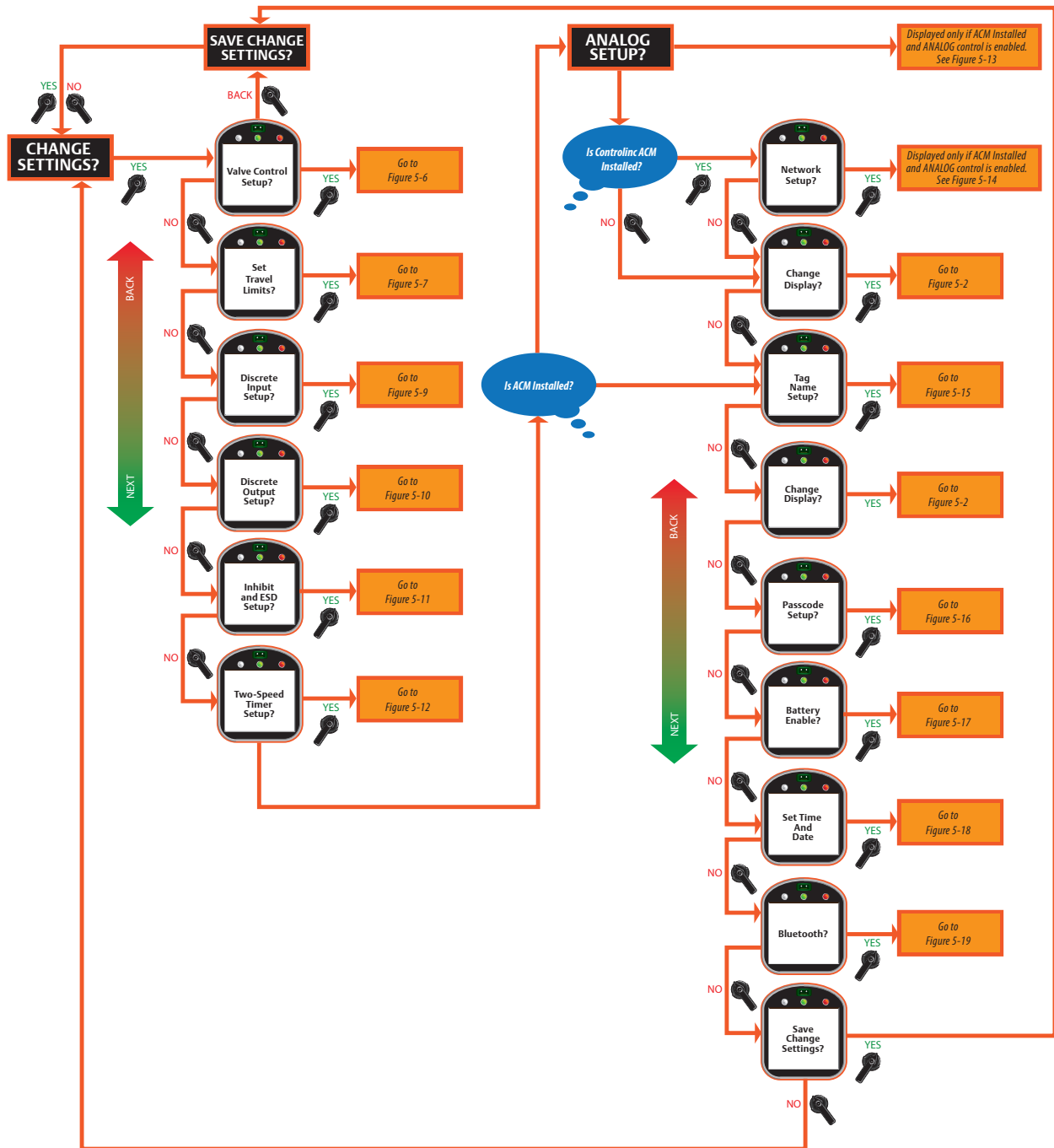
**NOTE:**

A passcode must be entered to change settings.

---

3. Use the selector knob (**NEXT/BACK**) to scan the display for the desired setting to change the following:
  - Valve control setup
  - Valve travel limits
  - Discrete input
  - Discrete output
  - Inhibit and ESD
  - Two-speed timer
  - Analog
  - Network
  - Tag name
  - Passcode

Figure 5-4 Change Settings



### 5.5.1 Passcode Entry

The actuator is shipped with “000” as a passcode. To change the passcode see **Section 5.5.11, Passcode Setup**.

To enter the passcode:

1. At the “**CHANGE SETTINGS?**” prompt answer “**YES.**” “**ACCEPT PASSCODE CHARACTER 1? X**” will appear. “**X**” will be flashing. “**X**” is the first “left most” character in the passcode.
2. If this character is correct, select **YES**. If not select **NO**. Use **NO** to increment from 0-9 and then A-Z until the correct character is displayed. Select **YES**.  
The second character will flash.

---

**NOTE:**

When “Z” is displayed the data will rollover to “0” and continue incrementing.

---

3. Repeat Step No. 2 for the second and third characters.

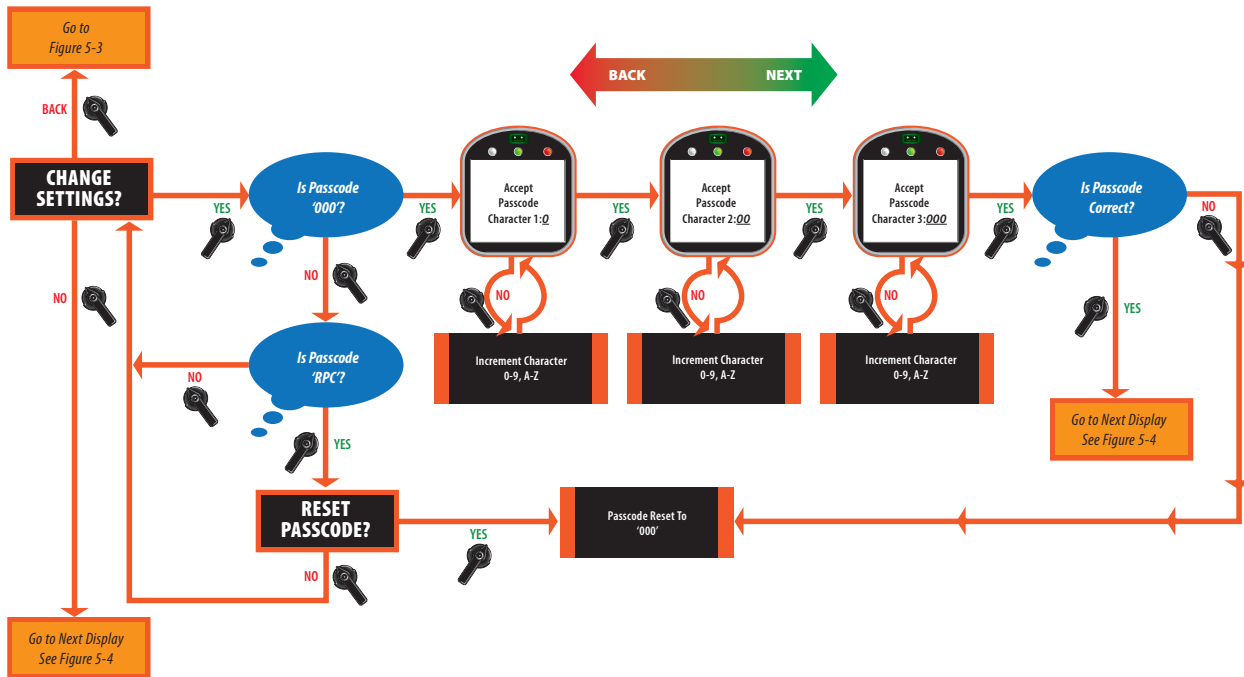
---

**NOTE:**

If the passcode is not the correct passcode, the display will return to “**CHANGE SETTINGS?**” display. See **Figure 5-5**.

---

Figure 5-5 Passcode Entry



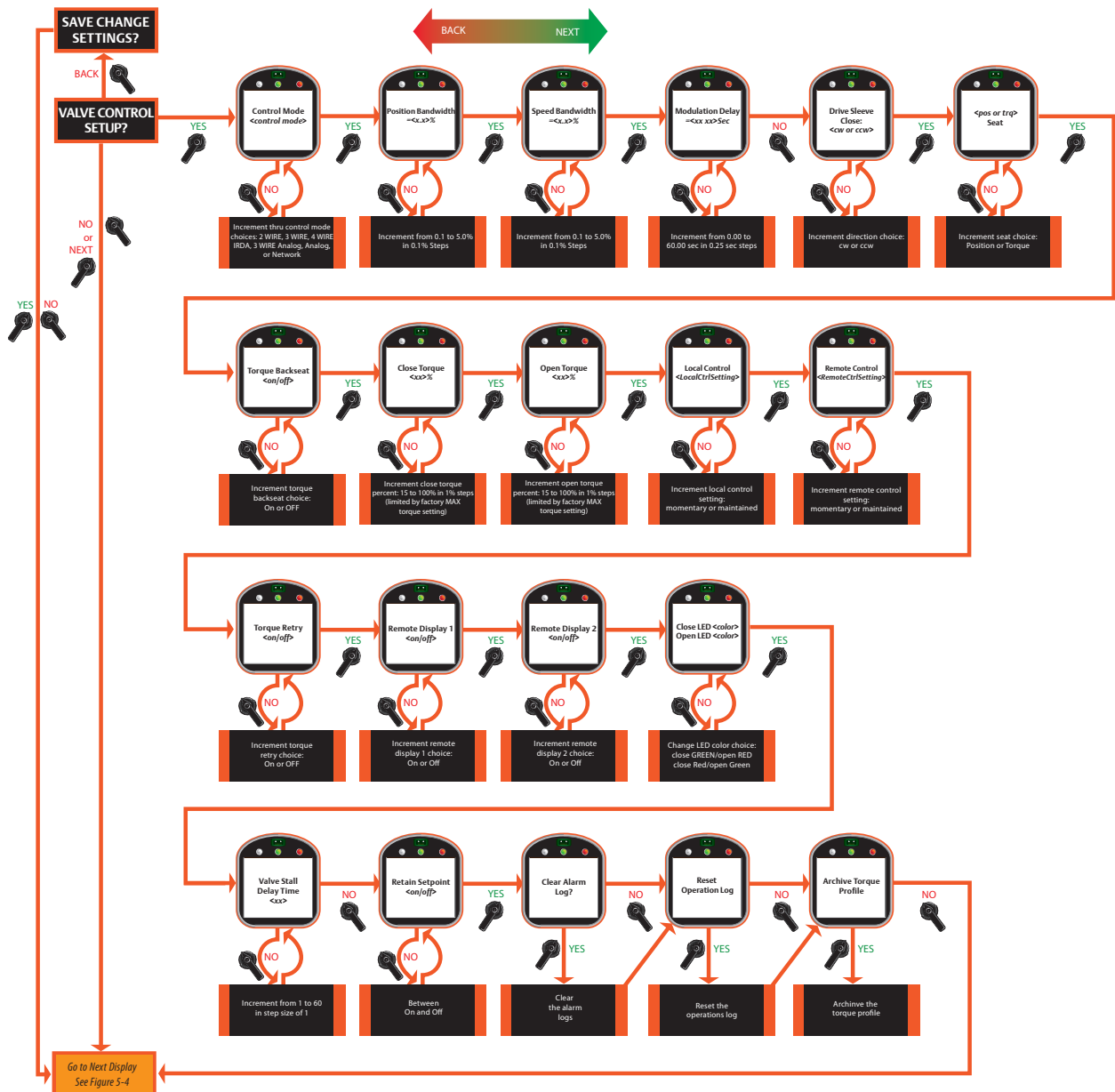
### 5.5.2 Valve Control Setup

1. At the “**VALVE CONTROL SETUP?**” prompt answer “**YES.**”
2. Use the selector knob (**NEXT/BACK**) to scan the settings until the desired setting is reached. Place the control knob in the **NO** position to increment through each setting’s associated choices. Answer “**YES**” to accept the desired choice. See **Figure 5-6**.

See **Section 4.5, Remote/Auto Control Operation**, for a description of each control mode.

Figure 5-6 Valve Control Setup

Associated choices are listed below each setting.



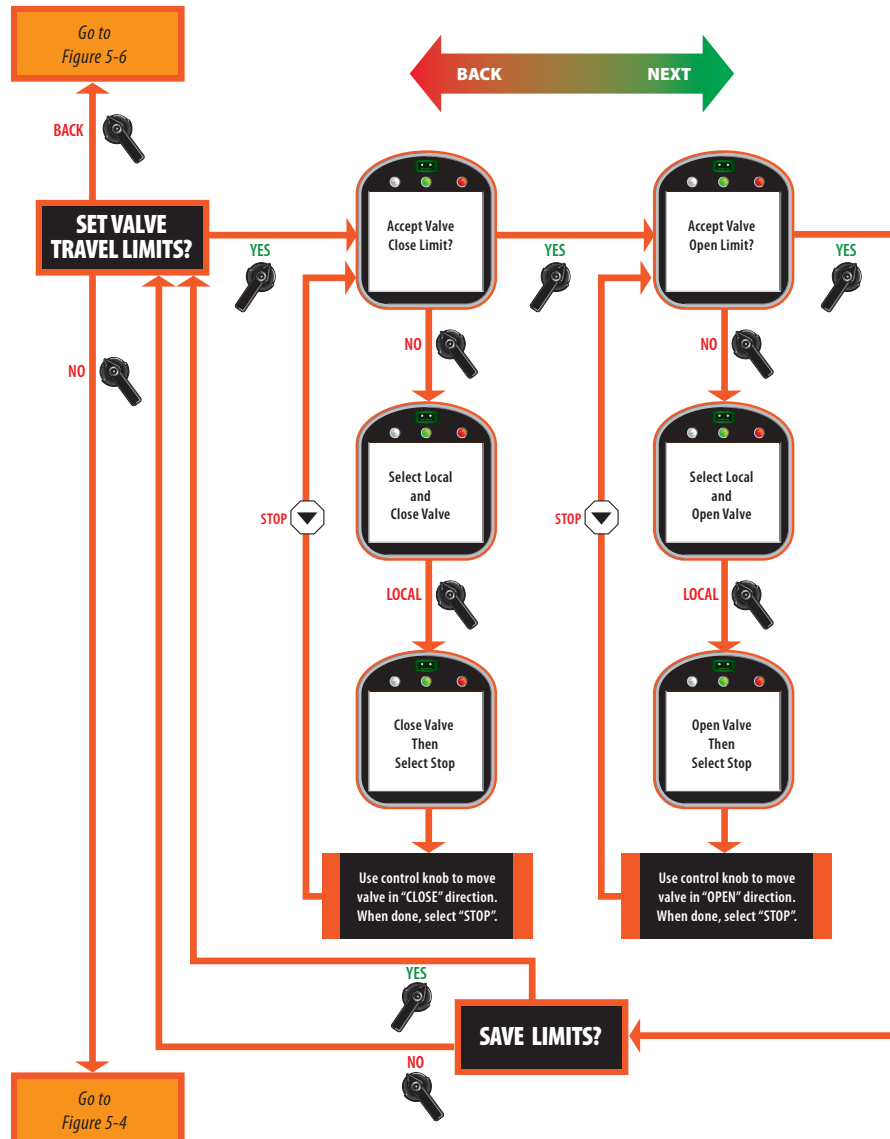
### 5.5.3 Set Valve Travel Limits

1. If the close limit is acceptable, answer **“YES.”** If not rotate the selector knob to **LOCAL**. Close valve to desired limit, rotate selector knob to **STOP**, and answer **YES**.
2. If the open limit is acceptable, answer **“YES.”** If not rotate the selector knob to **LOCAL**. Open valve to desired limit, rotate selector knob to **STOP**, and answer **YES**.

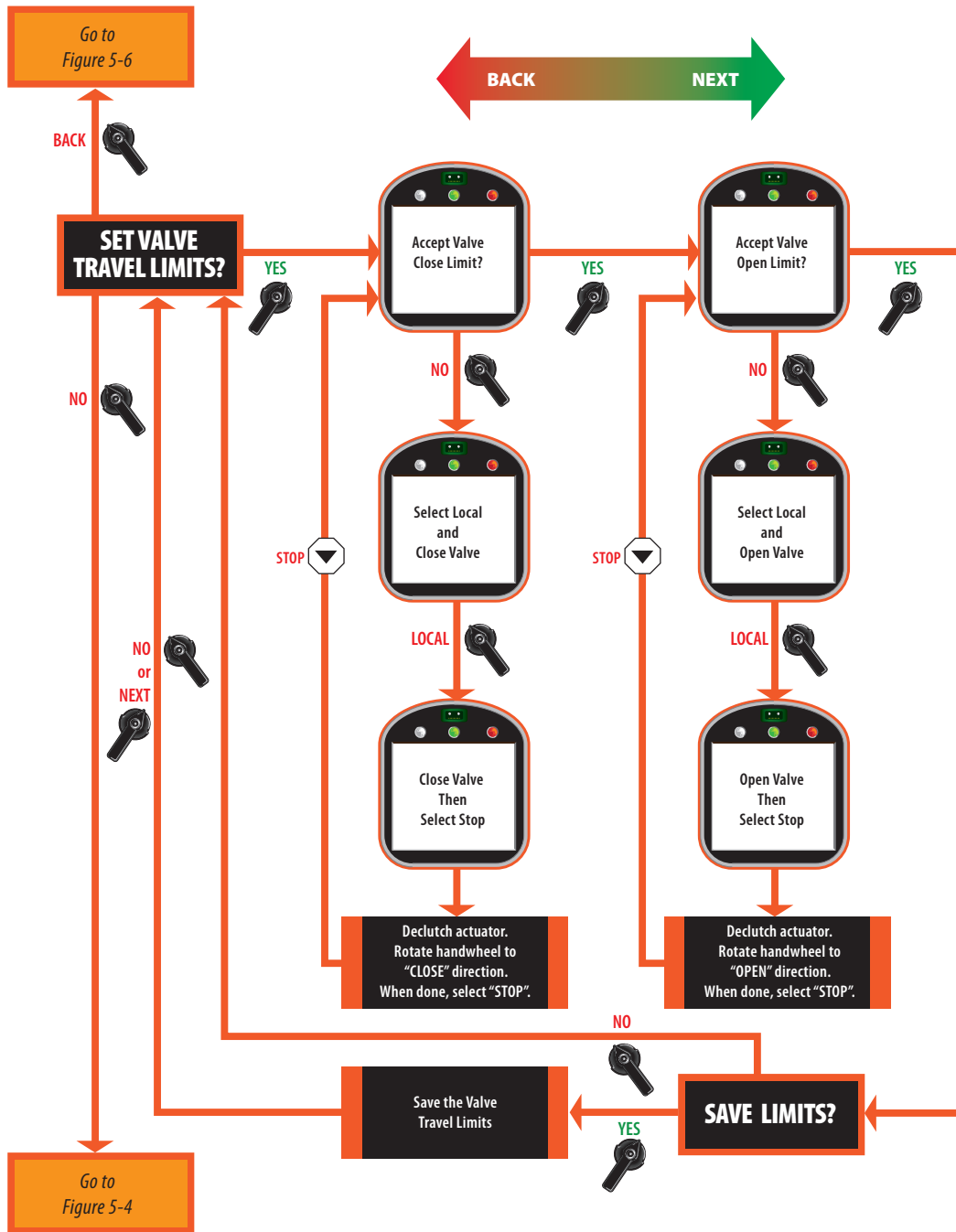
See **Figures 5-7 and 5-8**.

**Figure 5-7 Set Valve Travel Limits**

Normal Operation Mode - Set Limits with Electrical Operation



**Figure 5-8 Set Valve Travel Limits**  
Normal Operation Mode - Set Limits with Handwheel Operation



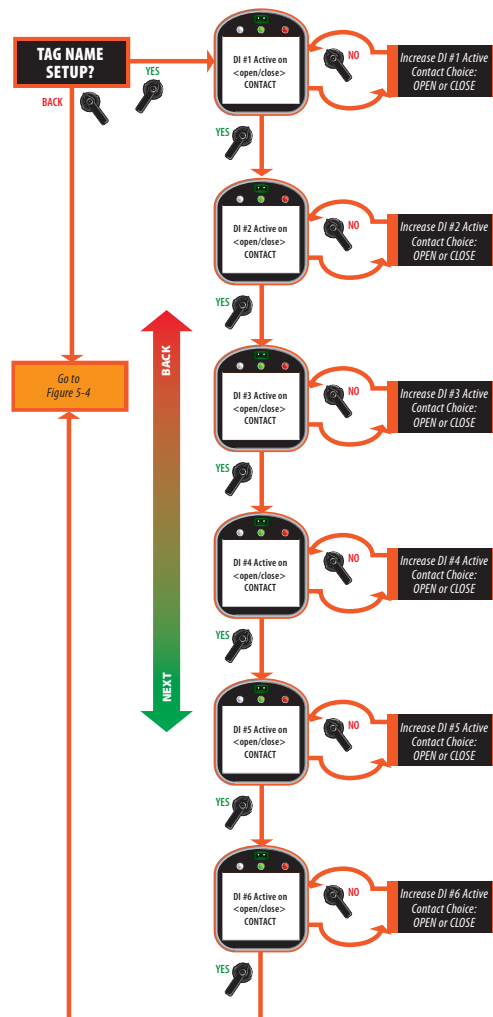
### 5.5.4 Discrete Input Setup

1. At the “**DISCRETE INPUT SETUP**” prompt answer “**YES.**”
2. Use the selector knob (**NEXT/BACK**) to review the setting for each discrete input.
3. For Input DI #1, use the control knob (**NO**) to select either “**ACTIVE ON CLOSED CONTACT**” or “**ACTIVE ON OPEN CONTACT.**” After selection is made, answer “**YES.**”
4. Repeat Step No. 3 for the remaining 5 inputs.

Discrete inputs are used primarily for remote control operation. Refer to **Section 4.5, Remote/Auto Control Operation**, for valve control setup using the discrete inputs.

For connecting a discrete input see **Section 3.5, Discrete Controlled Inputs**. See **Figure 5-9**.

**Figure 5-9 Discrete Input Setup**  
Configuration of discrete inputs are shown below.





### 5.5.5 Discrete Output Setup

Relay outputs are used primarily for hard wired status feedback. Each relay may be configured (assigned) to various status, alarm, or control functions. Relay outputs can be configured to be active on the listed alarms/conditions. Relay outputs #1 through #5 are standard and may be configured as shown in **Table 5-1**. Configurable functions are listed in **Table 5-2**.

To configure the relays:

1. At the “**DISCRETE OUTPUT SETUP?**” prompt answer “**YES.**”
2. Use the selector knob (**NEXT/BACK**) to review the settings for Discrete Outputs.
3. Use the control knob (**NO**) to select desired configuration for each relay.

See **Figure 5-10**.

**Table 5-1. Relay Outputs #1 through #5 Configuration**

Relay	Default Function	Configurable Function	Configure N.O./N.C.	Default Setting	Configure Flashing
RO#1	LSO Valve full OPEN	See <b>Table 5-2 Relay Output Function List</b>	Yes	N.O.	Yes
RO#2	LSC Valve full CLOSE	See <b>Table 5-2 Relay Output Function List</b>	Yes	N.O.	Yes
RO#3	LSO Valve Full Open	See <b>Table 5-2 Relay Output Function List</b>	Yes	N.O.	Yes
RO#4	LSC Valve Full Close	See <b>Table 5-2 Relay Output Function List</b>	Yes	N.O.	Yes
RO#5	Monitor Valve not available	<b>Host Control</b> – see NOTE	No	1 N.O. and 1 N.C.	Yes

**NOTE:**

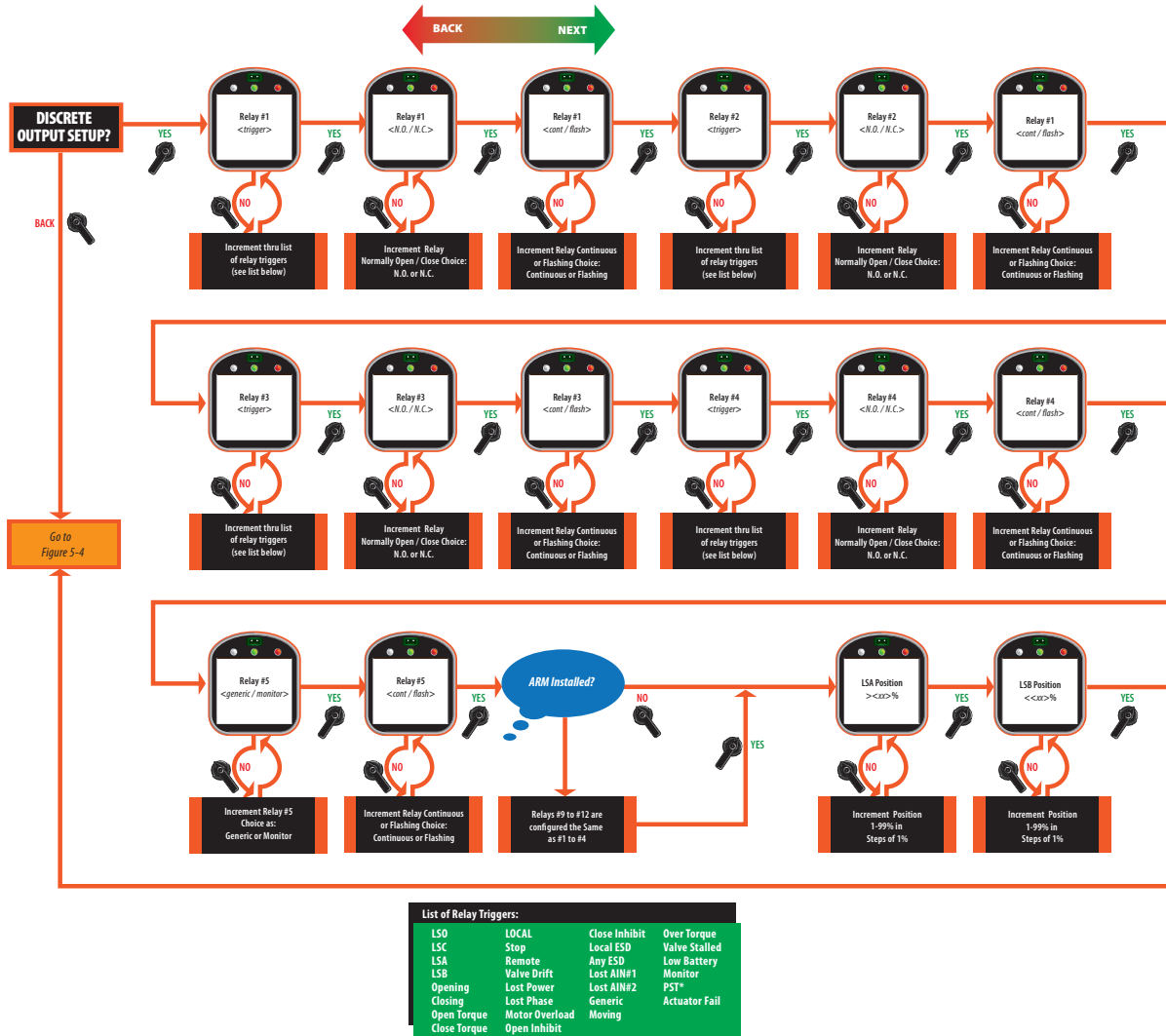
Host Control means the control of this relay has been given to the network if a Controlinc card has been installed. The relay will not function if the Controlinc card is not installed. Flashing means the output will cycle ON and OFF in one-second intervals while the function is active.

**Table 5-2. Relay Output Function List**

• LSO (Open limit)	• LOW BATTERY	• VALVE STALL	• LOCAL ESD
• LSC (Close limit)	• LOCAL	• VALVE DRIFT (MOVED BY HANDWHEEL)	• ESD ACTIVE
• LSA (Intermediate limit A)	• STOP (SS OFF)	• LOST POWER	• LOST ANALOG
• LSB (Intermediate limit B)	• REMOTE	• MOTOR OVERLOAD	• ACTUATOR FAIL
• OPENING	• OPEN TORQUE	• LOST PHASE	• HOST CONTROL (Controlled by Network)
• CLOSING	• CLOSE TORQUE	• OPEN INHIBIT	• LOST COM A/B
• MOVING	• OVER TORQUE (Open or Close)	• CLOSE INHIBIT	• UNIT ALARM
			• Partial Stroke Test (PST)*

*\*Only available for Relays 3 and 4.*

Figure 5-10 Discrete Output Setup



**NOTE:**

\*Only available for Relays 3 and 4.

Relays #9 through #12 are the auxiliary relays when the Auxiliary Relay Module (ARM) is installed. To configure these relay outputs, follow Step No.1 through No. 3 listed above. See **Table 5-3**.

---

**NOTE:**

The ARM cannot be added when the Controlinc ACM is installed.

---

**Table 5-3. Relay Outputs #9 through #12 Configuration**

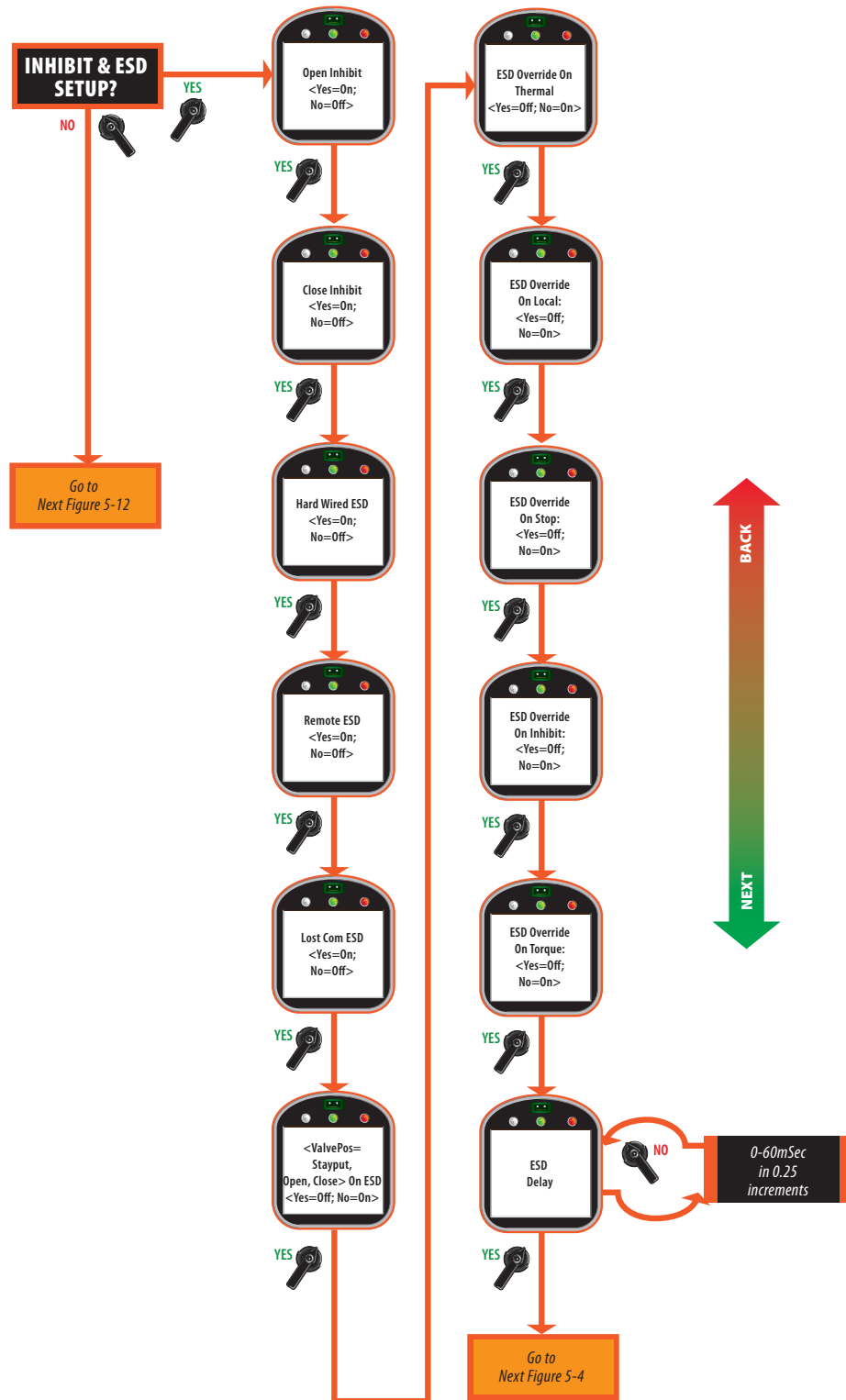
Relay	Default Function	Configurable Function	Configure N.O./N.C.	Default Setting
RO#9	Lost Power	See <b>Table 5-2 Relay Output Function List</b>	Yes	N.O.
RO#10	Motor Overload	See <b>Table 5-2 Relay Output Function List</b>	Yes	N.O.
RO#11	Lost Phase	See <b>Table 5-2 Relay Output Function List</b>	Yes	N.O.
RO#12	Over Torque	See <b>Table 5-2 Relay Output Function List</b>	Yes	N.O.

### 5.5.6 Inhibit and ESD Setup

1. At the **“INHIBIT AND ESD SETUP?”** prompt answer **“YES.”**
2. Use the selector knob (**NEXT/BACK**) to review the settings for Control Inhibits and Emergency Shut Down.
3. Use the control knob (**NO**) to select either **ON** or **OFF** for each setting; then answer **“YES.”**

**Figure 5-11** details each setting.

Figure 5-11 Inhibit and ESD Setup



### 5.5.7 Two-Speed Timer Setup

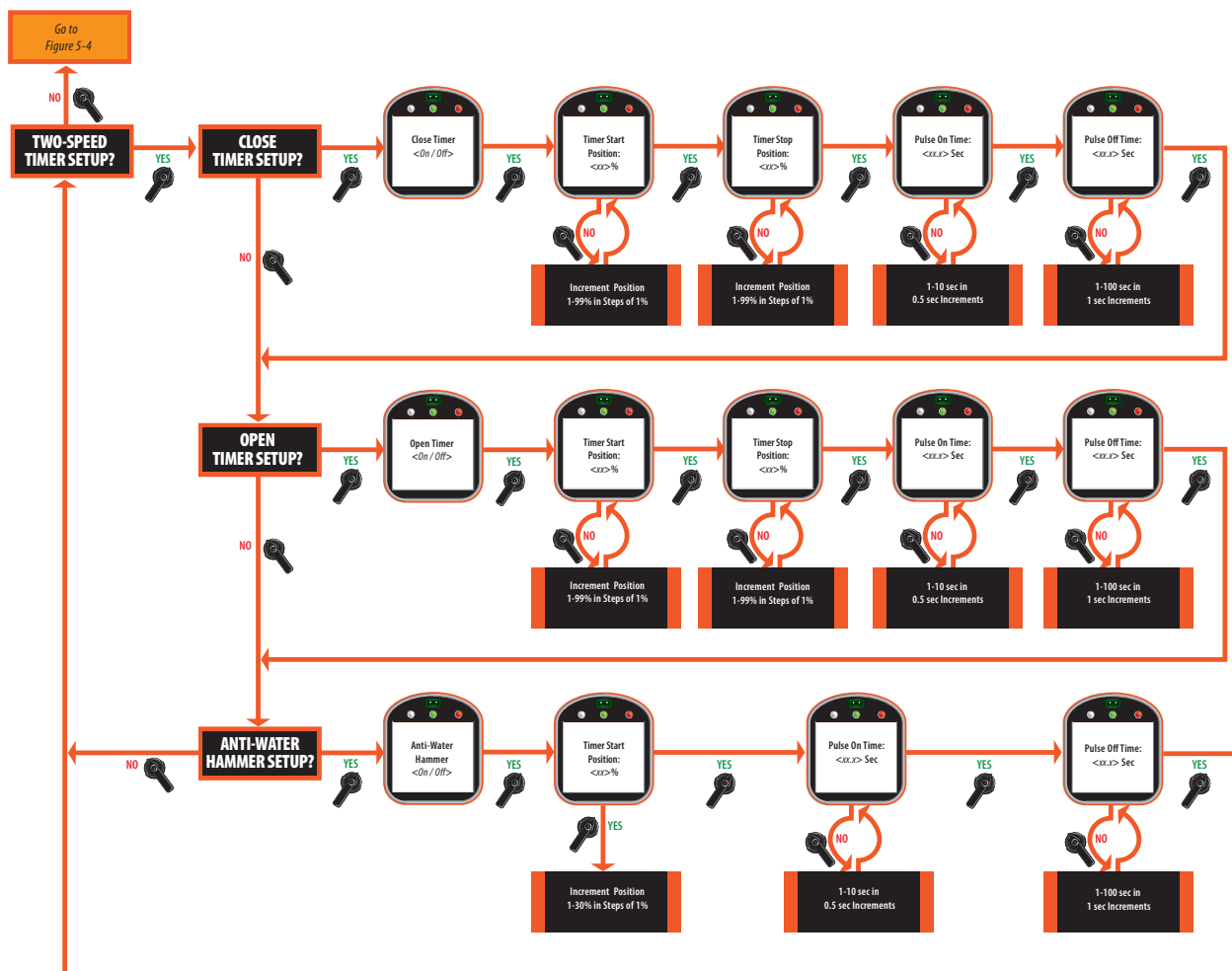
The two-speed timers can be configured for the actuator to be controlled with different opening and closing times. All configured timers are active in the LOCAL and REMOTE modes.

**NOTE:**

All three timers, close, open, and anti-water hammer, can operate at the same time. If two timer ranges overlap, the anti-water hammer timer overrides all timers.

1. At the “TWO-SPEED TIMER SETUP?” prompt answer “YES.”
2. Use the selector knob (NEXT/BACK) to review the settings for each timer.
3. Use the control knob (NO) to select either ON or OFF, increment the position percentage, and pulse time.
4. Answer “YES” after each selection. See Figure 5-12.

Figure 5-12 Two-Speed Timer Setup



### 5.5.8 Analog Setup (ACM Required)

---

**NOTE:**

Only displayed/applicable if the ACM is installed and analog control is enabled in the valve control setup. See **Section 5.5.2, Valve Control Setup**.  
All analog I/O are loop powered.

---

1. At the “**ANALOG SETUP?**” prompt, answer “**YES.**”
2. Use the selector knob (NEXT/BACK) to review the settings for analog control.
3. Use the control knob (**NO**) to increment the bandwidths and delay time, to select polarity and lost signal parameters, and to calibrate analog in/out.
4. Answer “**YES**” after each selection. See **Figure 5-13**.

To calibrate analog input, connect a calibrated precision 4-20mA current source to Terminal 25(+) and 26(-) for AIN#1.

To calibrate analog input AIN#2, connect a calibrated precision 4-20mA current source to Terminal 27(+) and 28(-).

To calibrate analog outputs, the user must connect a calibrated precision 4-20mA current meter to Terminals 31(+) and 32(-) for AO#1 or Terminals 29(+) and 30(-) for AO#2.

To calibrate analog output AO#2, the user must connect a calibrated precision 4-20mA current meter to terminals to 33(+) and 34(-).

Figure 5-13 Analog Setup

NOTE: The actuator senses that the Futronic ACM is installed and adjusts the display sequence to display only one input.

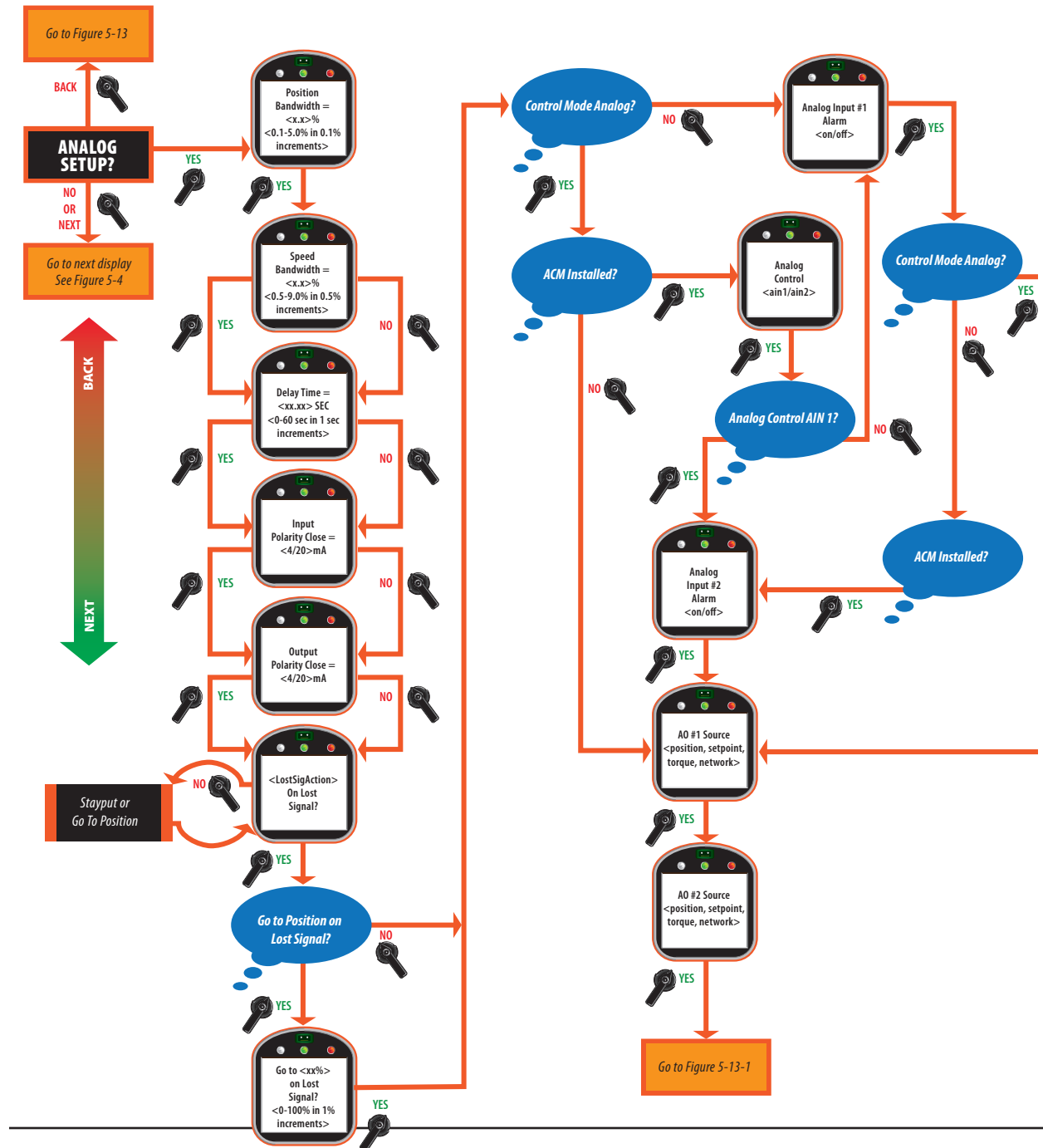




Figure 5-13-1 Analog Input 1 Calibration Setup

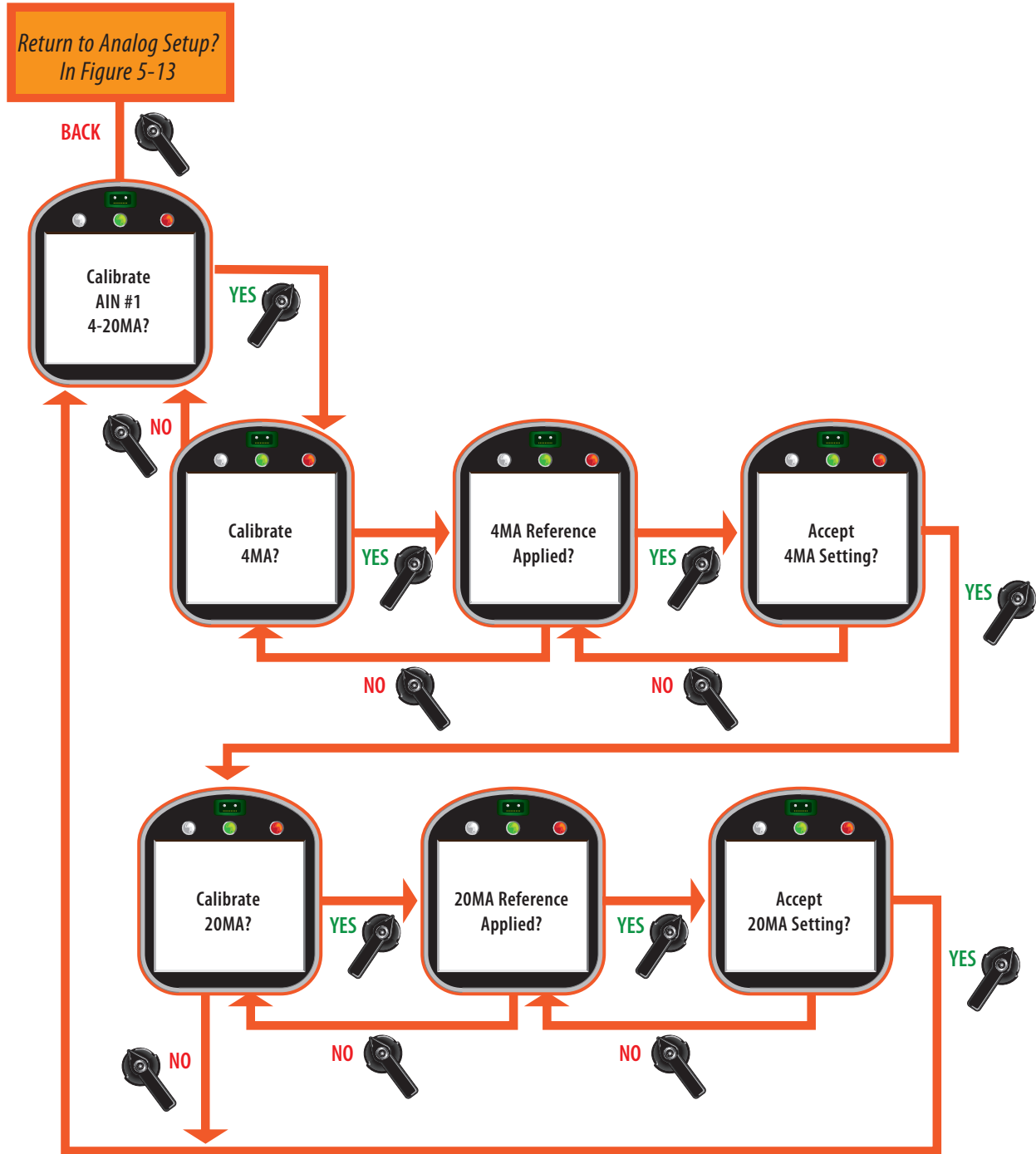


Figure 5-13-2 Analog Input 2 Calibration Setup

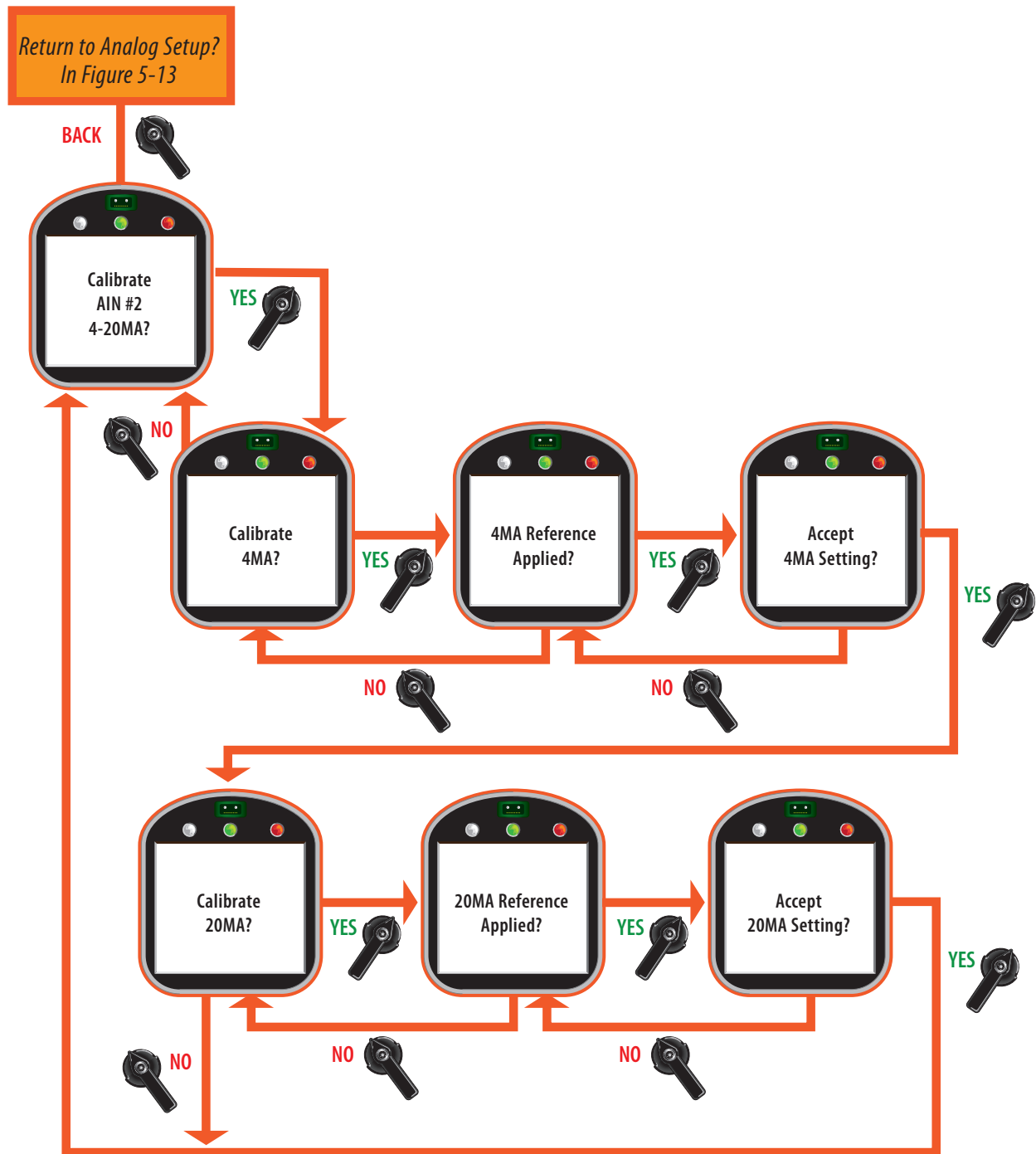


Figure 5-13-3 Analog Output 1 Calibration Setup

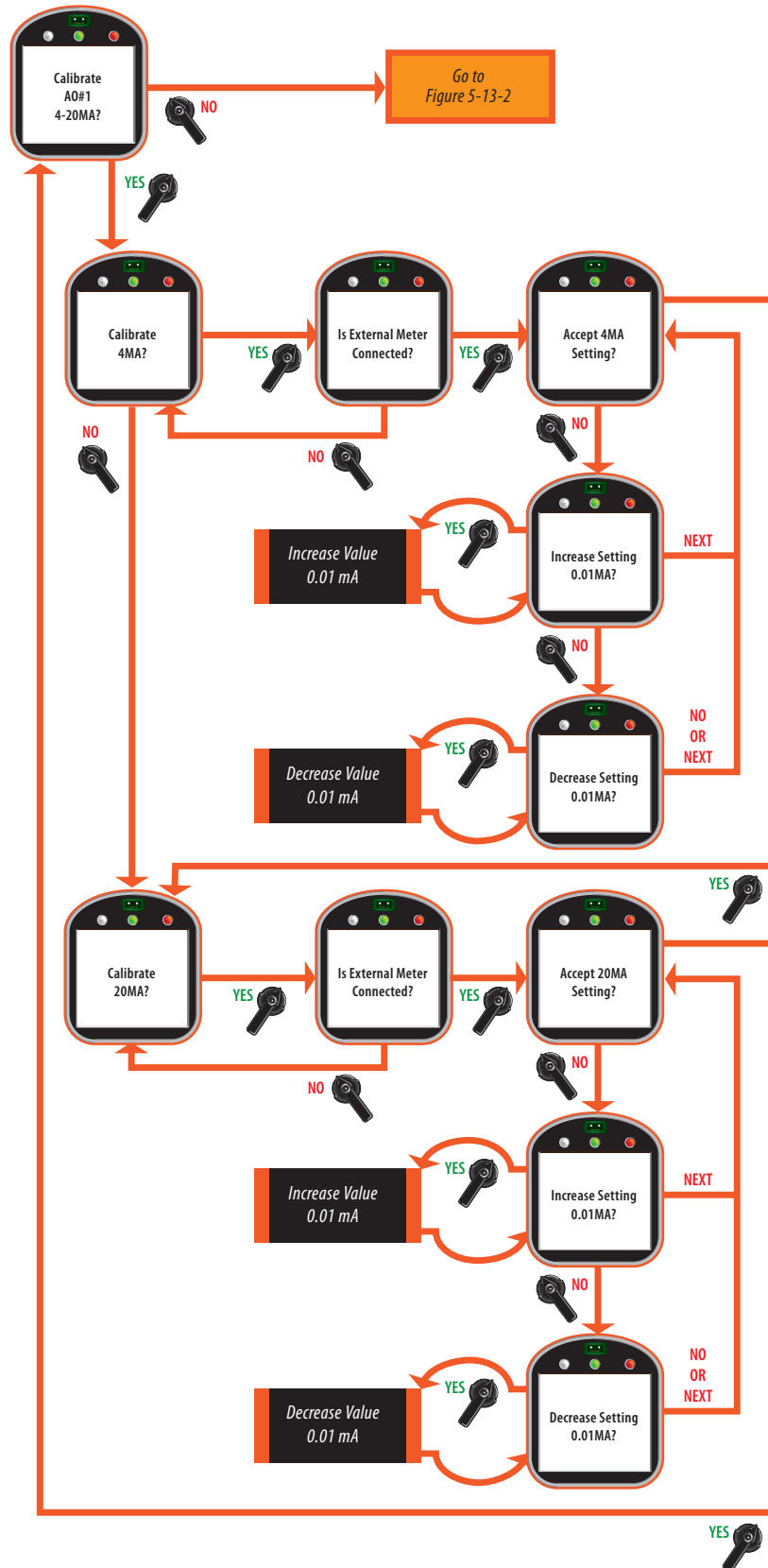
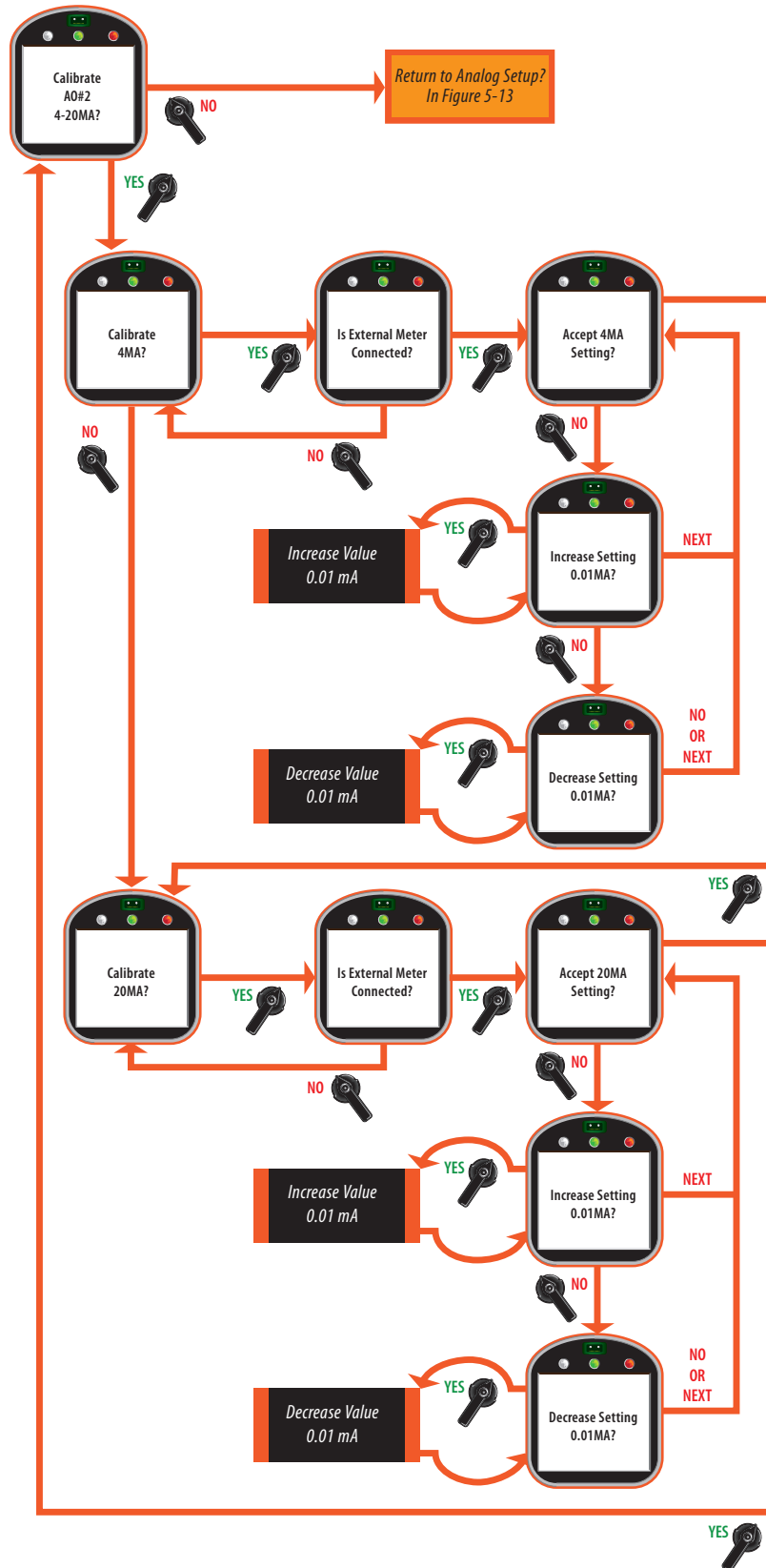


Figure 5-13-4 Analog Output 2 Calibration Setup



### 5.5.9 Network Setup (CAM and Controlinc ACM Required)

---

**NOTE:**

Only displayed/applicable if the Communication Adapter Module (CAM) and the Controlinc ACM are installed, and the network control is enabled.  
See **Section 5.5.2, Valve Control Setup.**

---

1. At the “**NETWORK SETUP?**” prompt, answer “**YES.**”
2. Use the selector knob (**NEXT/BACK**) to review the settings for network control.
3. Use the control knob (**NO**) to increment the node address, response delay, and analog I/O scale, and to select the parity, and analog scale.
4. Answer “**YES**” after each selection.

See **Figure 5-14.**

Protocol is set at the factory by the selected CAM based on purchase order information. Protocol may not be changed by the user in the field. Only factory technicians may change the CAM or protocol in the field.

Baud rate is automatically defined by the Controlinc ACM and no setup is required. To calibrate analog inputs, the user must connect a calibrated precision 4-20mA current source to Terminals 25(+) and 26(-) for AIN#1 or Terminals 27(+) and 28 (-) for AIN#2. To calibrate analog output, the user must connect a calibrated precision 4-20mA current meter to Terminals 29(+) and 30(-) for AO#1.

Figure 5-14 Network Setup

**NOTE:** The actuator senses that the Controlinc ACM is installed and adjusts the display sequence to display only one output.

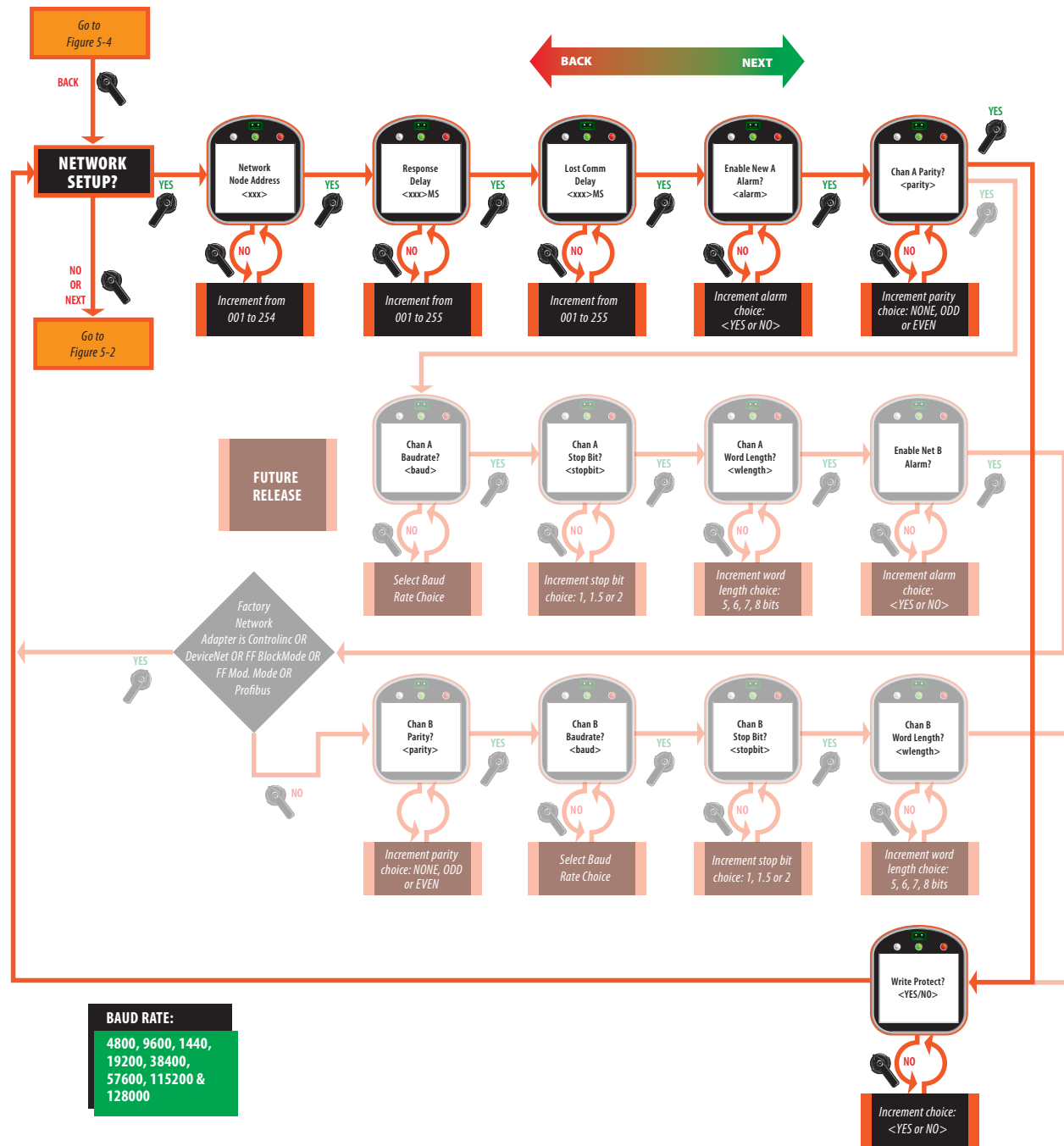
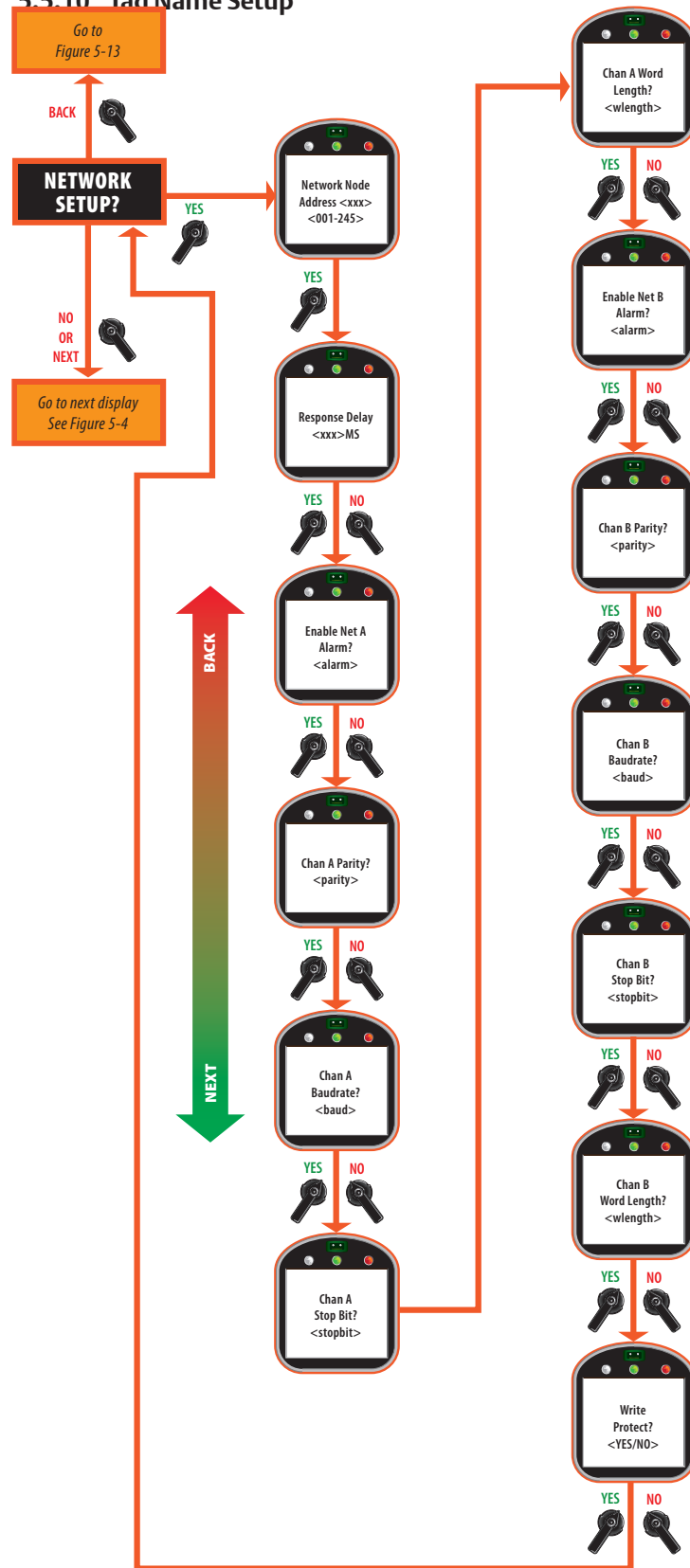


Figure 5-14-1 Network Setup Display Menu  
5.5.10 Tag Name Setup



1. At the “TAG NAME SETUP?” prompt, answer, “YES.”
2. Use the control knob (**NO**) to increment the data entry selection for each character.

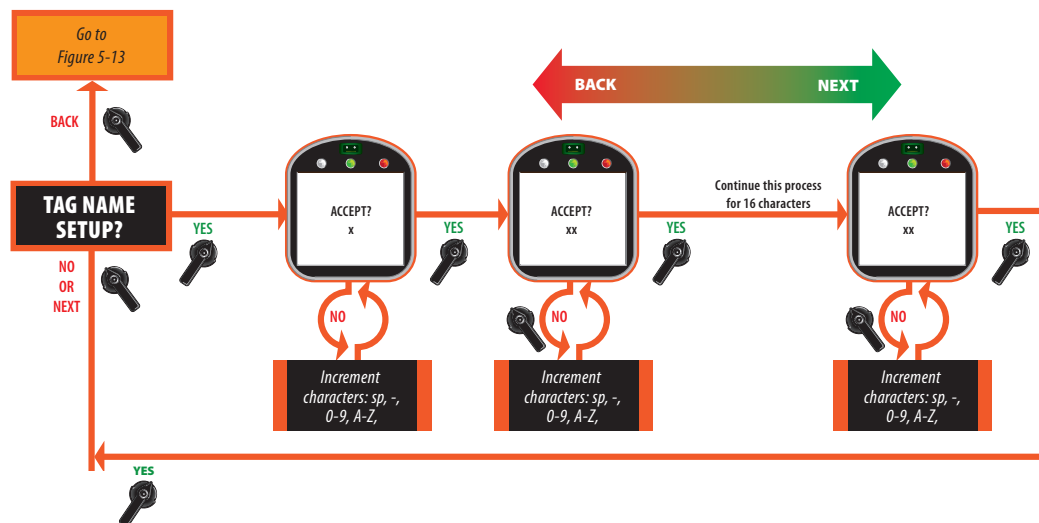
**NOTE:**

The tag name consists of a maximum of sixteen characters. Spaces and dashes are included in the sequence of “space,” “-,” “0-9,” “A-Z.”

3. At the “ACCEPT?” prompt, answer, “YES” for each character.
4. Use the selector knob (**BACK**) to make changes to the previous characters in the tag name while entering the data.

See **Figure 5-15**.

**Figure 5-15** Tag Name Setup Menu





### 5.5.11 Passcode Setup

The passcode may be changed via the passcode setup sequence.

1. At the **“PASSCODE SETUP?”** prompt, answer **“YES.”**
2. Use the control knob (**NO**) to increment the data entry selections of 0-9 and A-Z for each character. The passcode consists of 3 characters.
3. Use the selector knob (**BACK**) to make changes to the previous characters in the passcode while entering the data.
4. Answer **“YES”** to the **“ACCEPT PASSCODE CHARACTER X? X”** prompt.
5. Repeat Step No. 2 and 3 until all three characters have been entered.

---

**NOTE:**

This new passcode must be entered the next time changes are made.

---

Figure 5-16 Passcode Setup Menu

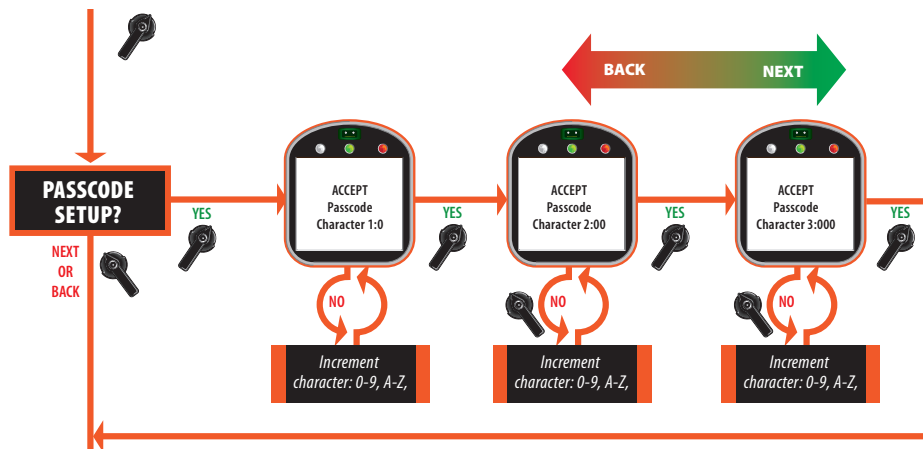


Figure 5-17 Battery Enable Menu

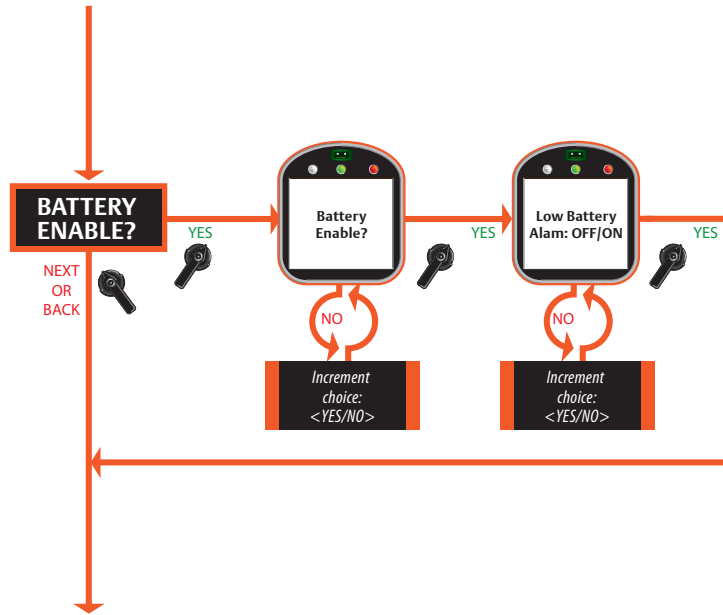
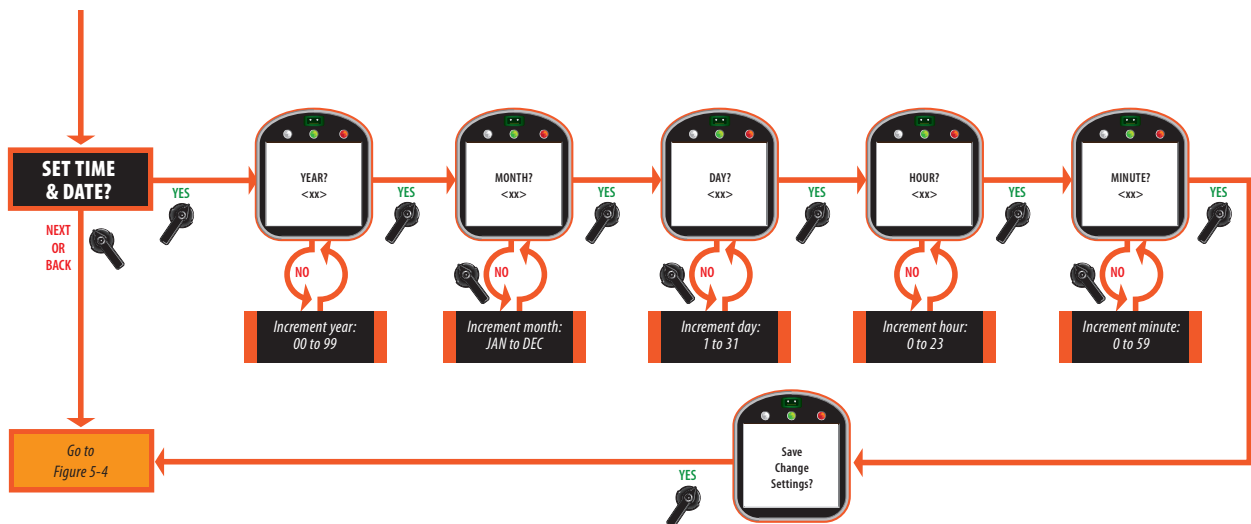


Figure 5-18 Set Time and Date Menu



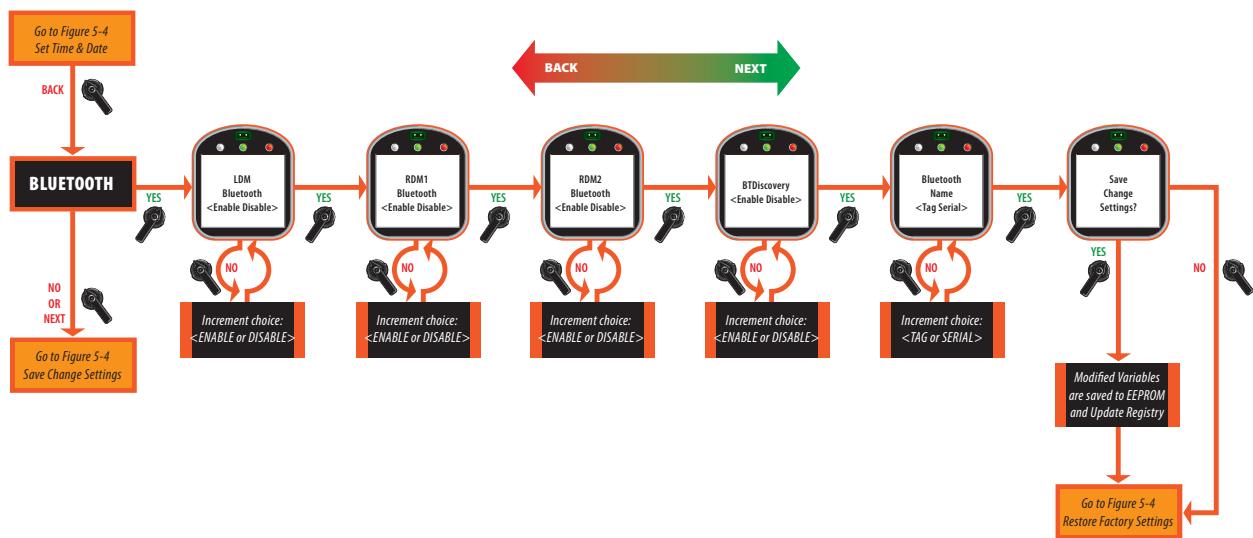
### 5.5.12 Reload Factory Settings

Factory default settings are detailed in **Table 4-4**. Factory settings do not overwrite valve travel limits or analog calibration.

**CAUTION:**

**CLEAR LOGS** only clears the alarm log, torque profile, and resets the operation log.

Figure 5-19 Bluetooth



**NOTE:**

Only 1 Bluetooth module can be enabled.

## Section 6: Troubleshooting

### ⚠ CAUTION:

This actuator is non-intrusive. Do not open the control compartment on the actuator unless absolutely necessary. It was sealed in dry-clean conditions in the factory and entry into this compartment should not be necessary. Unauthorized entry could void the warranty.

### 6.1 Troubleshooting Problems/Corrective Action for Actuator Operation

Symptom	Probable Cause	Corrective Action
Motor will not Run	Blown Control Fuse	Check Fuse and Replace as necessary
	Open in Control Circuit	Refer to appropriate wiring diagram and check for continuity
	Insulation Resistance Breakdown in Motor	Perform Megger Test
No Power available to Actuator	Tripped Circuit Breaker	Reset Circuit Breaker
Handwheel Hard to Turn	Valve Stem improperly Lubricated	Lubricate with Grease
	Actuator Lubrication has broken down	Clean out old grease and replace with recommended lubricant
	Valve packing gland too tight	Loosen packing gland nuts as necessary
	Drive Sleeve Bearing Failure	Replace Bearing
	Jammed Valve	Refer to Valve Maintenance
Valve only opens or closes partially with motor	Torque Switch Setting too low	Check Setting and Reset if necessary
	Limit Switch Improperly Set	Check Switch Actuation and re-calibrate if necessary
Torque switch is properly set, but actuator Torque's out in mid-travel, open or closed direction	Damaged or bent valve stem	Refer to Valve Maintenance
	Valve packing too tight	Refer to Valve Maintenance
	Jammed Valve (obstruction in line)	Refer to Valve Maintenance
Handwheel will not operate valve	Handwheel shaft bearing assembly malfunction	Repair or replace as necessary
	Sheared gear key or Stripped Gearing	Replace as necessary
	PS Shifter Position or Malfunction	Replace Gear(s)
	Broken Handwheel Shaft	Repair or replace as necessary
Motor runs but will not operate the valve	Broken Valve Stem or Stripped Stem Nut	Repair or replace as necessary
	Motor Bearing Assembly Malfunction	Repair or replace as necessary
	Sheared gear key (fastener pin)	Replace
	Stripped Gearing	Replace
	Broken Valve Stem or Stripped Stem Nut	Repair or replace as necessary

If the LDM does not receive communication messages from the CCM within 5 seconds after power is applied or loses communication for 5 seconds or more, it will display a flashing message "CCM LINK FAILED" and blink all three LEDs.

## 6.2 Display Diagnostics

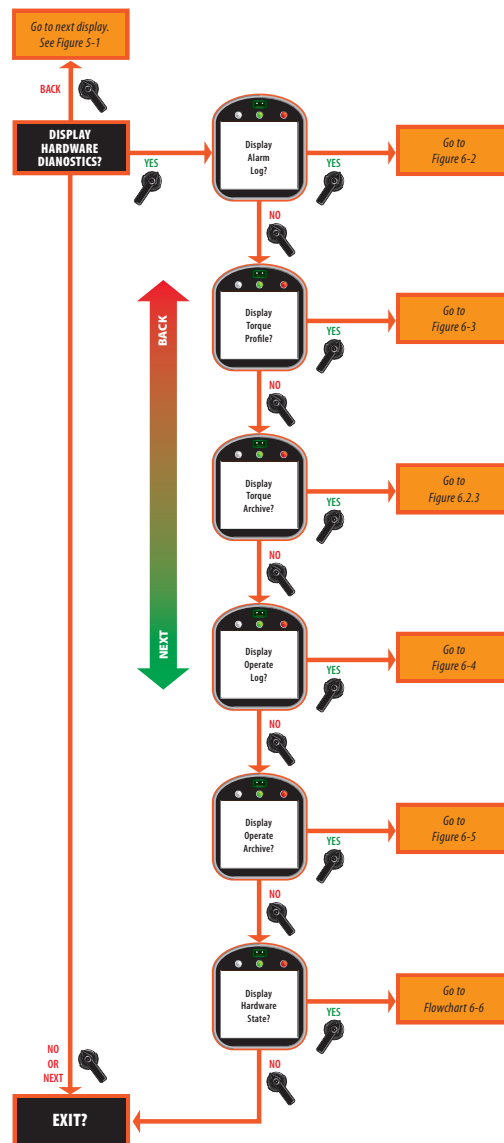
Displaying diagnostics retrieves historical data that is stored in the actuator's memory. This aids in troubleshooting.

1. At the “**DISPLAY HARDWARE DIAGNOSTICS?**” prompt, answer “**YES.**”
2. Use the selector knob (NEXT/BACK) to review the settings. See **Figure 6-1**.

**NOTE:**

When the “**SET LIMITS BEFORE OPERATING**” alarm is displayed, no other alarms will be displayed until the limits are set.

**Figure 6-1** Display Diagnostics



### 6.2.1 Display Alarm Log

At the time the alarm occurs, the alarm is displayed on the bottom line of the message center. This display lists the last nine alarms that have occurred. The first alarm listed is the most recent to occur. The alarm list progresses from the most recent to the oldest. The following alarms may be displayed.

EFM MONITOR	OPEN INHIBIT
OPEN TORQUE_%	CLOSE INHIBIT
CLOSE TORQUE_%	LOCAL ESD
VALVE STALLED	REMOTE ESD
VALVE DRIFT	LOST AIN1 SIGNAL
POWER FAIL	ACTUATOR FAIL
LOST PHASE	SETUP ERROR
MOTOR OVERLOAD	SET LIMITS BEFORE OPERATING

**NOTE:**

When the “**SET LIMITS BEFORE OPERATING**” alarm is displayed, no other alarms will be displayed until the limits are set.

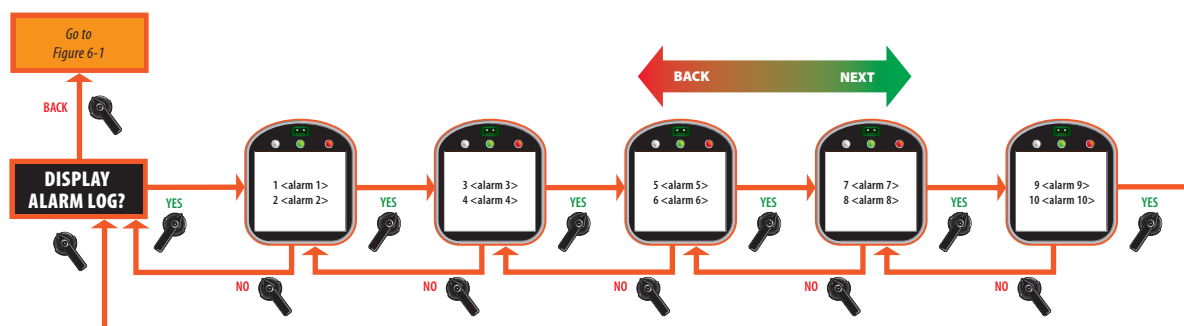
1. At the “**DISPLAY ALARM LOG?**” prompt, answer “**YES.**”
2. Use the selector knob (**NEXT/BACK**) to review the alarms. See **Figure 6-2.**

**NOTE:**

The control knob (**YES/NO**) can be used to view the alarms however do not cycle the control knob between **NO** and **YES** because the unit could display the “**SETUP**” mode.

3. Use the control knob (**NO**) to exit the display.

**Figure 6-2 Display Alarm Log Example**



### 6.2.2 Display Torque Profile

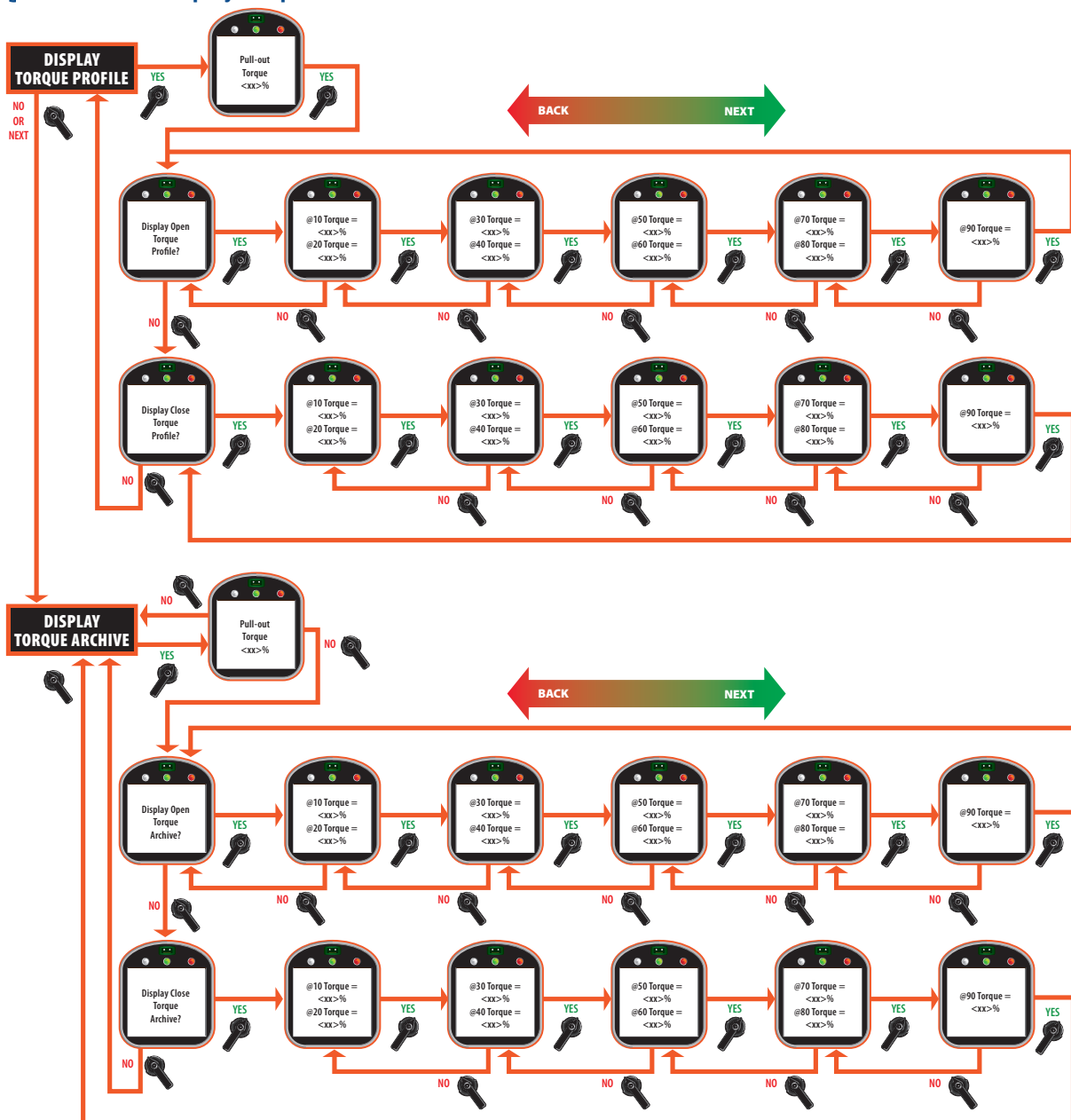
Torque profile is data on the last stroke. Torque data is recorded at 10% intervals of valve travel and is displayed for both open and close directions. Pullout torque is peak torque recorded in the open direction from 0 to 90% while unseating the valve.

1. At the “**DISPLAY TORQUE PROFILE?**” prompt, answer “**YES.**”
2. Use the control knob (**YES**) to review the torque profiles. See **Figure 6-3.**

**NOTE:**

Two positions of torque data are shown for each “YES” that is selected.

**Figure 6-3 Display Torque Profile**



### 6.2.3 Display Torque Archive

Torque archive is displayed like Torque Profile. Torque archive is the data stored at the time commanded by the user in the “CHANGE SETTINGS” mode. See **Section 5.5.2, Valve Control Setup** and **Figure 5-6**.

1. At the “DISPLAY TORQUE ARCHIVE?” prompt, answer “YES.”
2. See **Section 6.2.2, Display Torque Profile**, and **Figure 6-3**.

### 6.2.4 Display Operation Log

Operation log aids in troubleshooting because it contains the operation data accumulated since the operation log was reset. See **Figure 6-4**.

1. At the “DISPLAY OPERATE LOG?” prompt, answer “YES.”
2. Use the control knob (YES) to review the operate log.

Motor starts value is the number of times the motor has been started. The strokes value displayed is the number of full strokes from limit to limit. Stroke time can be measured as follows:

1. Reset operation log.
2. Stroke the valve. Stroke time is equal to the motor run time.

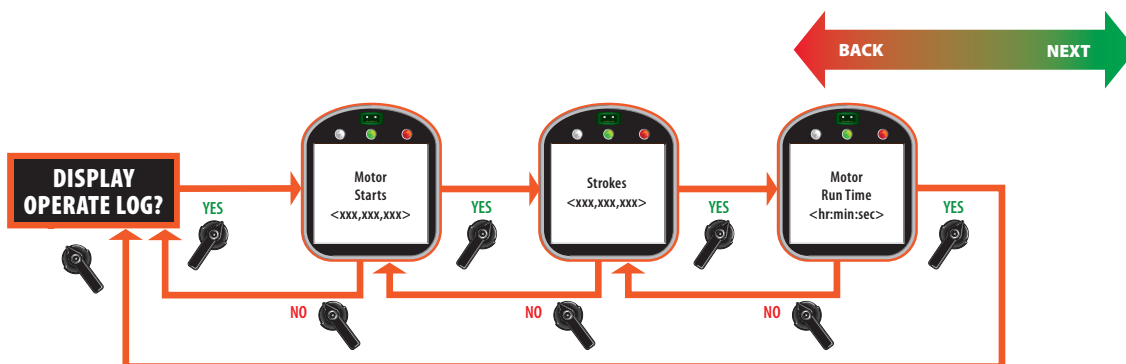
Motor run time is the total motor operational time.

To reset operation log:

1. Enter “Change Settings” mode.
2. Select “VALVE CONTROL SETUP?”

See **Section 5.5.2, Valve Control Setup**

**Figure 6-4** Display Operation Log



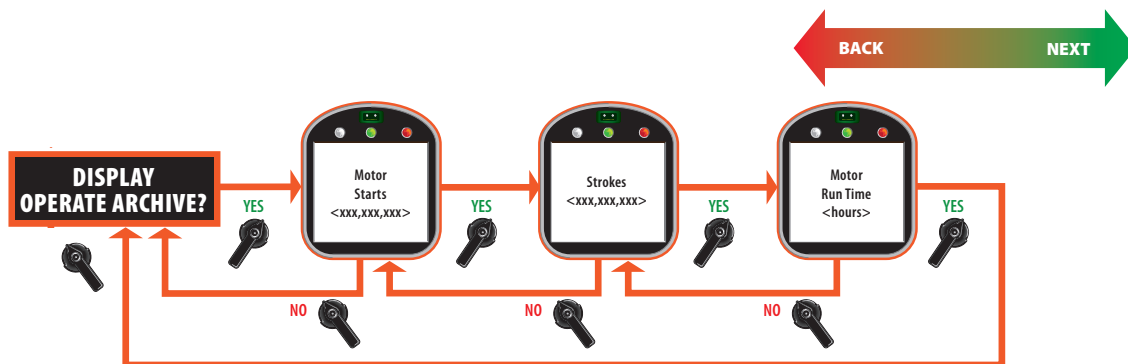


### 6.2.5 Display Operation Archive

Operation archive displays operation data from the initial commissioning. See **Figure 6-5**. The operation archive cannot be reset in the “CHANGE SETTINGS” mode. The operation archive can be reset in the “FACTORY SETUP” mode; however the actuator must be decommissioned and travel limits must be reset before operating as detailed in **Section 4.3.1, Setting Position Limits**.

1. At the “DISPLAY OPERATE ARCHIVE” prompt, answer “YES.”
2. Use the control knob (YES) to review the operation archive.

Figure 6-5 Display Operation Archive



### 6.2.6 Display Hardware

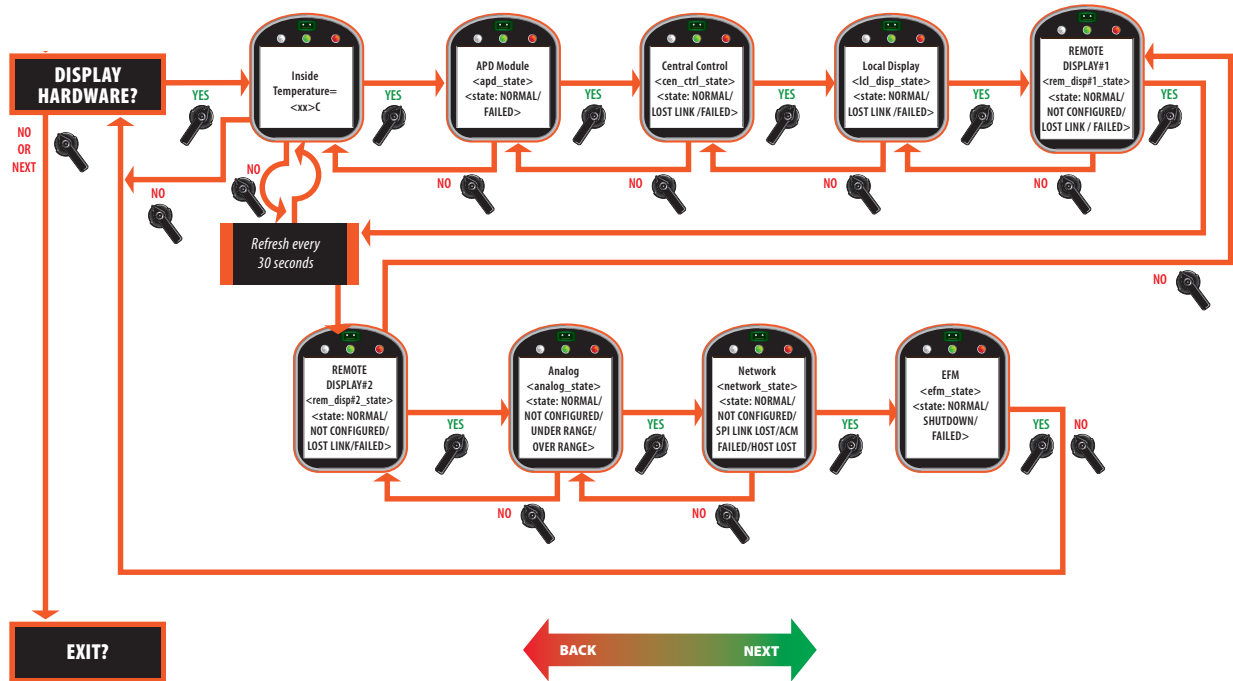
This display reports the status of the modules and can identify which module is at fault if a problem exists with the actuator. Typical status report can include:

- Normal
- Not Configured
- Lost Link
- Failed

1. At the “DISPLAY HARDWARE?” prompt, answer “YES.”
2. Use the control knob (YES) to review the hardware status.

See **Figure 6-6**.

Figure 6-6 Display Hardware



## Section 7: Maintenance

### 7.1 Maintenance Schedule

TEC2 Series Actuators have been designed and manufactured to provide years of trouble free service. Minimal maintenance is required.

It is not unusual to experience some minor grease weeping around seals during periods of long storage or inactivity. This is simply a separation of the oil in the compound and is not detrimental to the actuator operation. Once operation has begun, this situation should disappear.

### 7.2 Lubrication

Normal operation may not require lubricant during the life of the actuator. The basic lubricants used are multi-purpose extreme pressure specially formulated having a molybdenum disulfide additive.

### 7.3 Pressure Relief

During actuator operation, a small pressure builds up as a result of the gear temperature increase combining with the varied outdoor temperature.

1. After actuator has been located in the field and valve position has been determined, remove 1/2 NPT plug from the highest 1/2 NPT vent location on the gearbox.
2. Replace with Relief Vent Fitting Part No. 83385. See the EIM outline drawing supplied with the order submittal package for possible vent locations.

---

**NOTE:**

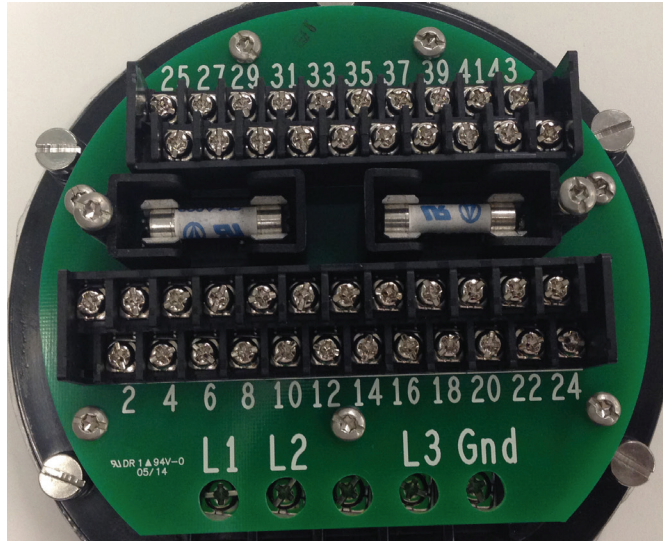
Model 500 will not have a pressure relief fitting. (Model 500 Discontinued)

---

### 7.4 Fuse Replacement

Two transformer primary fuses are located in the Separate Terminal Compartment (STC). To check or replace fuses, remove fuse cover by loosening the two Torx screws and slip cover out from underneath screws. Replace fuse only with 600V, 2A fuse, Bussmann TDC 600V 2A, EIM P/N 7019900425. Replace fuse cover and lightly tighten screws. Do not over-tighten.

Figure 7-1 Fuses in the STC



## 7.5 Lifting

Lifting eye should never be used for lifting and moving any TEC2 actuator. TEC2 actuators should be moved using straps.

## 7.6 Battery Disposal

Proper local battery disposal protocol should be followed.

## 7.7 Cleaning of LDM

Actuator external surfaces can be cleaned with water and/or mild detergent.




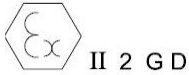


## 7.8 Improper Use

If actuator is not used in a manner specified in this manual, the protection provided by the equipment may be impaired.

## 7.9 Battery Replacement – “Clicker”

1. Insert a coin in the slot on the right hand corner of the key ring end and twist.
2. Slide battery to remove.
3. Replace battery with Panasonic Part No. CR2031 or equal.

## Section 8: Regulatory Information

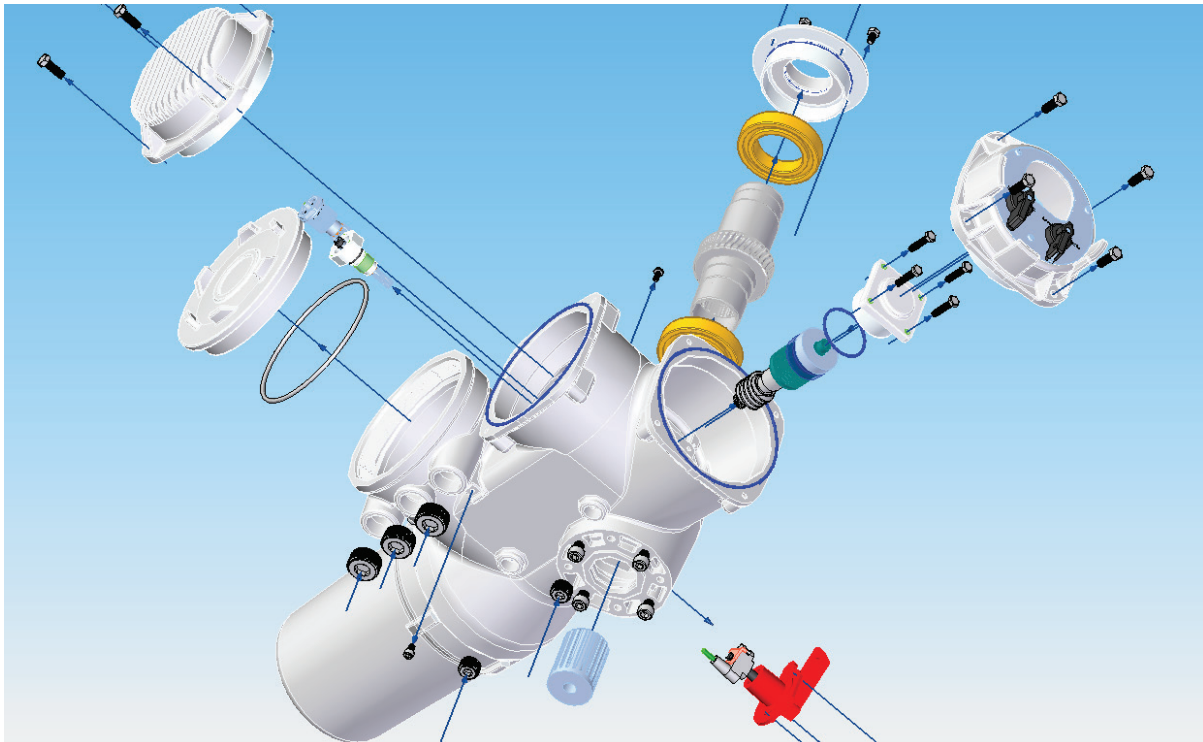
FM *		Class I, II, III Division 1 Groups B,C,D,E,F,G T4 @ Ta 60°C, Type 4X, 6P (50 ft for 7 days) T4 @ Ta 60°C, Type 4X, 6P (50 ft for 7 days)
CSA *		Class I, Groups B C & D, Class II Groups E,F,G, Class III T4 or T4A, Type 6P Class I, Groups D; T3C  RDM Class I, Groups B, C, D; Class II, Groups E,F,G; Class III; T6: Type 6P/4X  CBM Class I, Groups C and D; Class II, Groups E,F,G; Class III; T6: Type 6p/4X SIRA 03ATEX1510X
ATEX *	 	II 2 GD Ex d IIB T4 Gb Ex d IIB + H <sub>2</sub> T135°C Db IP68 Ex tb IIIC T135°C Db IP68 Ta -20°C to +60°C  The M8 fasteners used to secure each cover to the electronics enclosure and the RDM cover to the RDM enclosure are of property class (or 'grade') 8.8. The fasteners used to secure the motor enclosure to the electronics enclosure, the electronics enclosure to the gear box and the end caps to the motor frame are of property class (or 'grade') 5. Replacement fasteners shall meet these minimum values.  RDM  II 2 GD Ex d IIB +H <sub>2</sub> T6 Gb Ex tb IIIC T85°C Db 1P68 Ta -20°C to +60°C
IECEX *		IECEX SIR 12.0035X Ex d IIB T4 Gb Ex d IIB + H <sub>2</sub> T135°C Db IP68 Ex tb IIIC T135°C Db IP68 Ta -20°C to +60°C  RDM  II 2 GD Ex d IIB +H <sub>2</sub> T6 Gb Ex tb IIIC T85°C Db 1P68
GOST *	GOST	№POCC US.ГБ08.В00188 dtd 28.01.2013
InMetro *		CEPEL 08.1640X Ex d IIB T4 Gb IP68; Ta 60°C -20°C ≤ Tamb ≤ +60°C

**Note:**

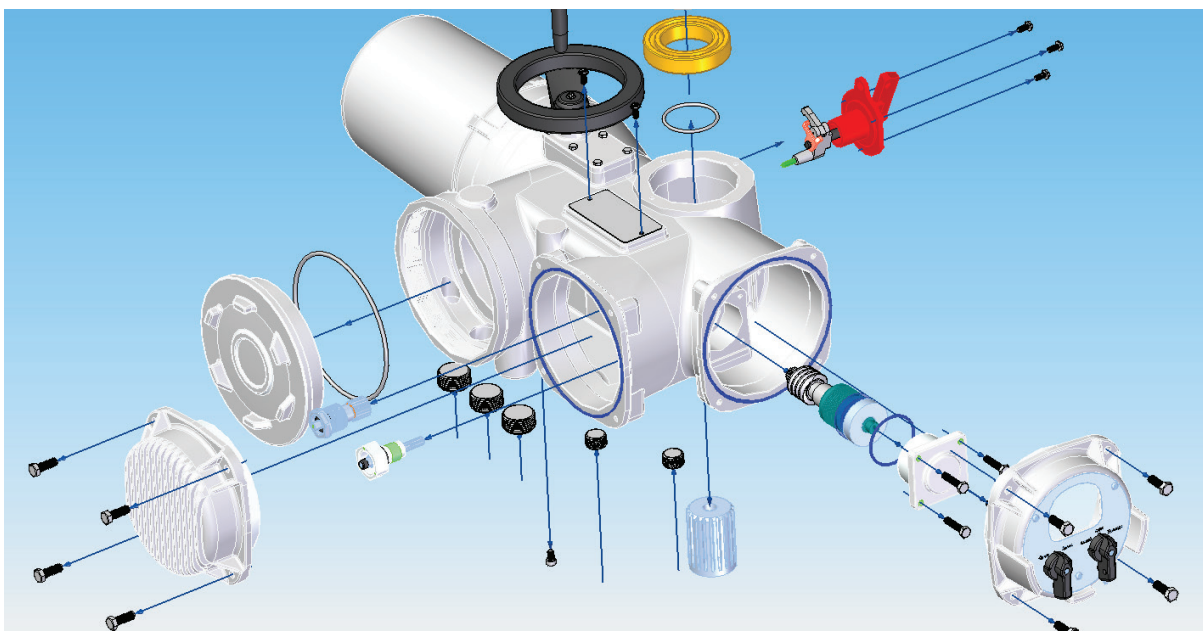
\* For Model 500 - Certification pending agency approval  
**(Model 500 Discontinued)**

## Appendix A:

### A.1 Exploded View (Model-500 Torque Unit Only) **(Model 500 Discontinued)**



**Bushing Underside**



**Bushing Upside**

## A.2 M-500 with Thrust Base Installation Drawing (Model 500 Discontinued)

Copyright © 2014 Emerson Process Management Valve Actuation LLC

REV	ECN	DATE
00	Released	12/17/2014

### SECTION A-A

**NOTES:**

**1** To insure locknut is secured: Drill .200 dia x .250 dp hole, and tap 1/4-20 UNC after locknut threads have been completely fastened to positions. Lock in place with SHSS p/n 4042205631.

\* Variable part: Refer to JOB SPEC SHEET for specific parts for each actuator serial number.

Item Number	Document Number	Title	Quantity
1	38242M	Model 500 Thrust Base Housing	1
* 2	38244-	Model 500 Stem Nut (Bronze)	1
3	38242-1M	Model 500 (TB) LockNut	1
4	4000100124	THBRG-51110 (70x50x14mm) - Peer	1
5	4045222617	O-Ring 568-226-70D	1
6	4060001200	Ret-Ring - 5100-2.00	1
7	4045222417	O-Ring 568-224-70D	1
8	4042205631	SHSS 1/4-20 UNC	1
9	4045214817	O-Ring 568-148-70D	1
10	4300090030	Grease fitting, 1/8-27 NPT SS	1

**TITLE:**  
Model 500 Thrust base  
ISO F10 Assembly

**EMERSON**  
Process Management

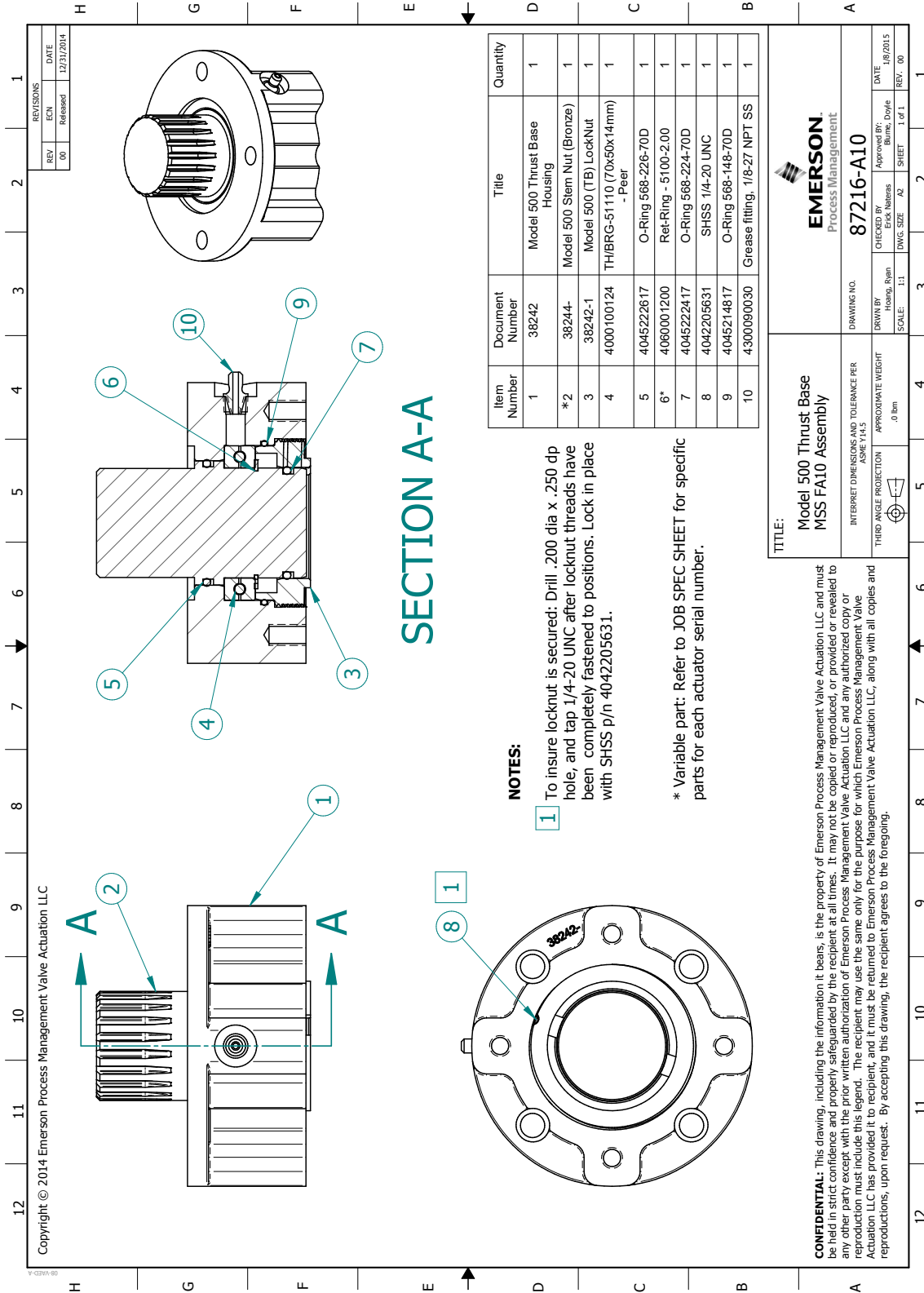
**87216-10**

DRAWING NO. 87216-10  
 DRAWN BY: Hoking, Ryan  
 CHECKED BY: Erick Maters  
 APPROVED BY: Doyle Beane  
 DATE: 1/8/2015  
 SCALE: 1 of 1 SHEET 00

INTERPRET DIMENSIONS AND TOLERANCE PER ANSI Y14.5  
 THIRD ANGLE PROJECTION  
 APPROXIMATE WEIGHT  
 .030 in

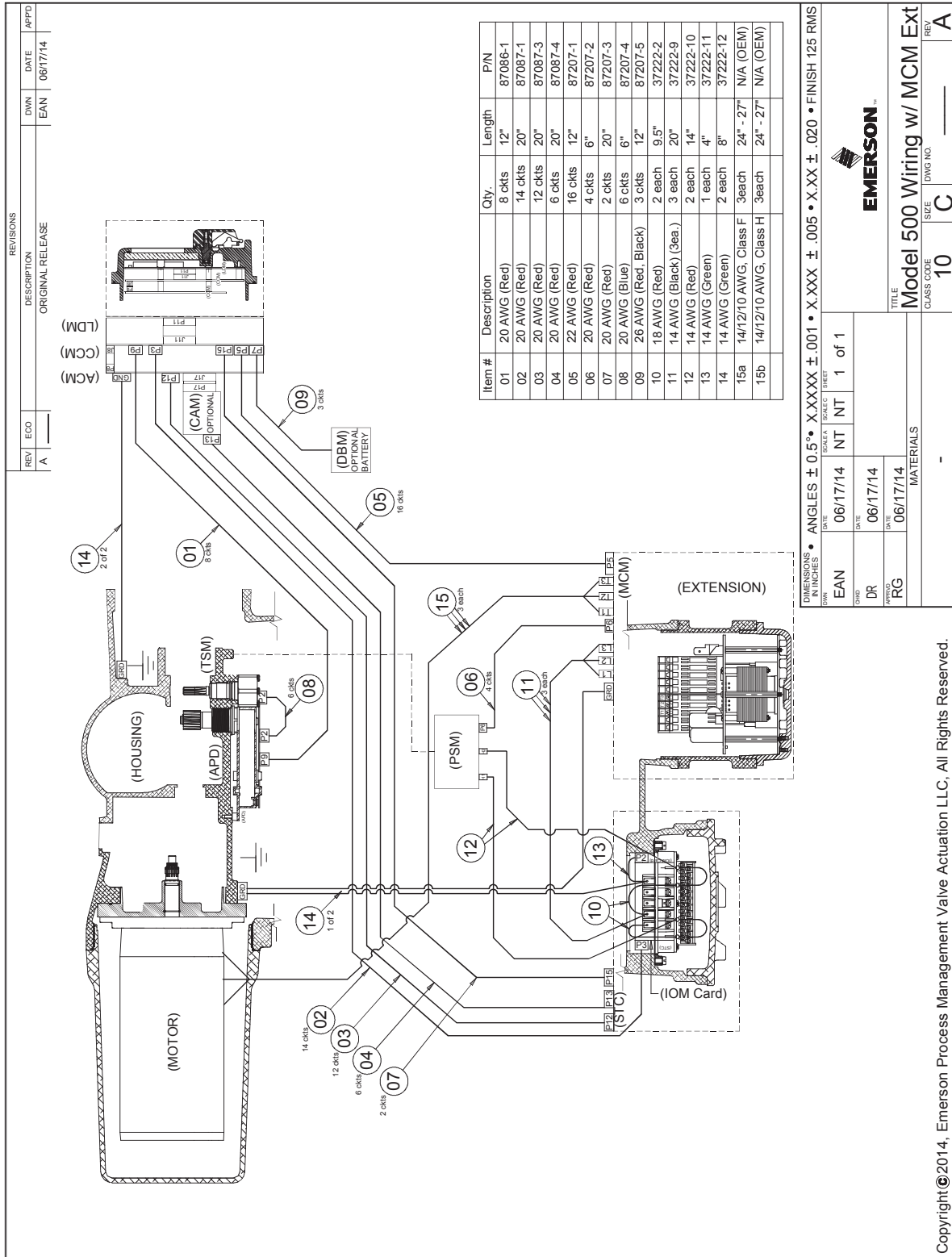
**CONFIDENTIAL:** This drawing, including the information it bears, is the property of Emerson Process Management Valve Actuation LLC and must be held in strict confidence and properly safeguarded by the recipient at all times. It may not be copied or reproduced, or provided or revealed to any other party except with the prior written authorization of Emerson Process Management Valve Actuation LLC and any authorized copy or reproduction must include this legend. The recipient may use the same only for the purpose for which Emerson Process Management Valve Actuation LLC has provided it to recipient, and it must be returned to Emerson Process Management Valve Actuation LLC, along with all copies and reproductions, upon request. By accepting this drawing, the recipient agrees to the foregoing.

**(Model 500 Discontinued)**





# A.3 Module Identification and Location (Model 500 Discontinued)



## A.4 Infrared Controller (IRC) – “Clicker”

(Not available in England or Japan)

The infrared controller, otherwise known as the “Clicker,” is a small key-size, handheld unit with four buttons as shown in the Figure below. The buttons are labeled as follows:

- YES
- NO - Stop
- NEXT - Open
- BACK - Close

These button functions correspond to the YES, NO, NEXT, and BACK functions of the control knobs on the LDM. The “Clicker” transmits operation commands only and the feedback information is displayed in the LDM LCD or the RDM LCD.

For the “Clicker” to control the actuator:

**Figure A-1 Clicker**



1. Enter “**SETUP**” mode using the control knobs as defined in **Section 5.1, Entering Setup Mode**.
2. Select “**LOCAL IrDA PORT**” for control mode under Valve Control Setup. See **Section 5.5.2, Valve Control Setup**.
3. Place the selector knob in the REMOTE position. Press the applicable “Clicker” button (Open, Close, Stop) for the desired function while “pointing” the back of the “Clicker” at the LDM or the RDM.

## A.5 IrDA Port

### IrDA Port

The local IrDA port control mode allows the actuator to be controlled via the IrDA port. The “Clicker” with an IrDA port may be used. The “Clicker” will transmit STOP, OPEN, and CLOSE only.

---

#### NOTE:

The setup mode cannot be entered via the IrDA port if this mode is selected in the “**SETUP**” mode. “**SETUP**” mode must be entered via the local control knobs and the control mode must be changed to a control mode other than IrDA port before the IrDA port can be used for setup.

---

## A.6 Disconnect - Circuit Breaker

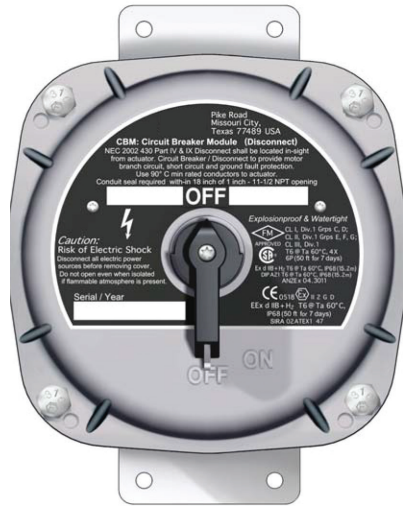
EIM has recognized need for disconnect as required by National Electric Code (NEC).

The NEC is clear in the specification of:

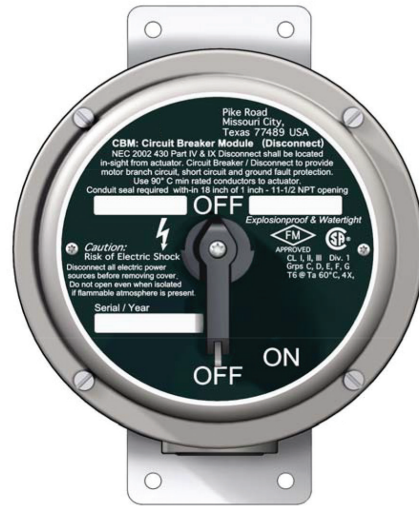
1. Disconnect shall be located insight from motor controller.  
**NEC 1996 430-102, Pg 70-446**
2. Disconnect shall open all ungrounded supply conductors.  
**NEC 1996 430-103, Pg 70-446**
3. Disconnect shall be permitted in enclosure with controller.  
**NEC 1996 430-103, Pg 70-446**
4. The disconnecting means shall be motor-circuit switch rated in horsepower or a circuit breaker.  
**NEC 1996 430-109, Pg 70-447**

**Figure A-2 Circuit Breaker Module (CBM)**

**CBM Suitable to Remote Wall or Pipe Mount. Also Available as Close-Coupled to Actuator.**



**Circuit Breaker Module (CBM) – Aluminum**



**Circuit Breaker Module (CBM) – Stainless Steel**

EIM CIRCUIT BREAKERS - CBM MOUNT		
Rated Current	EIM Part Number	Description
0.2	36525-0.2	CKT BKR-K0.2
0.5	36525-0.5	CKT BKR-K0.5
1	36525-1	CKT BKR-K1
1.6	36525-1.6	CKT BKR-K1.6
2	36525-2	CKT BKR-K2
3	36525-3	CKT BKR-K3
4	36525-4	CKTBKR-K4
6	36525-6	CKT BKR-K6
8	36525-8	CKT BKR-K8
10	36525-10	CKT BKR-K10
16	36525-16	CKT BKR-K16
20	36525-20	CKT BKR-K20
25	36525-25	CKTBKR-K25
32	36525-32	CKT BKR-K32
40	36525-40	CKTBKR-K40
50	36525-50	CKT BKR-K50
63	36525-63	CKT BKR-K63

## A.7 Common Bolt Tightening Torques

English Units: (Course Thread Series)

Thread Size and Pitch	GRADE 1		GRADE 2		GRADES 5, 5.2 & 5.1		GRADES 8, 8.1 & 8.2	
	Clamp Load (lb)	Tightening Torque (ft-lb)	Clamp Load (lb)	Clamp Load (ft-lb)	Clamp Load (lb)	Tightening Torque (ft-lb)	Clamp Load (lb)	Tightening Torque (ft-lb)
6 - 32	225	0.52	375	0.86	579	1.33	818	1.88
8 - 32	347	0.95	578	1.58	893	2.44	1260	3.44
10 - 24	433	1.37	722	2.29	1116	3.53	1575	4.99
12 - 24	599	2.16	998	3.59	1543	5.55	2178	7.84
1/4 - 20	787	3.28	1312	5.47	2027	8.45	2862	11.9
5/16 - 18	1297	6.75	2162	11.3	3341	17.4	4716	24.6
3/8 - 16	1918	12.0	3197	20.0	4941	30.9	6975	43.6
7/16 - 14	2631	19.2	4385	32.0	6777	49.4	9567	69.8
1/2 - 13	3512	29.3	5853	48.8	9046	75.4	12771	106
9/16 - 12	4505	42.2	7508	70.4	11603	109	16380	154
5/8 - 11	5594	58.3	9323	97.1	14408	150	20340	212
3/4 - 10	8267	103	8267	103	21293	266	30060	376
7/8 - 9	11435	167	11435	167	29453	430	41580	606
1 - 8	14999	250	14999	250	33633	561	54540	909
1-1/8 - 7	18884	354	18884	354	42347	794	68670	1288
1-1/4 - 7	23983	500	23983	500	53780	1120	87210	1817
1-3/8 - 6	28586	655	28586	655	64103	1469	103950	2382
1-1/2 - 6	34774	869	34774	869	77978	1949	126450	3161

Tightening Torque =  $K * D * P$

$K = 0.2$  (dry,unlubricated)

Clamp Load (P) = 75% of the Proof Load

D = Nominal Thread Size

Metric Units: (Course Thread Series)

Thread Size and Pitch	CLASS 4.6		CLASS 5.8		CLASS 9.8		CLASS 10.9	
	Clamp Load (KN)	Tightening Torque (N * m)	Clamp Load (KN)	Tightening Torque (N * m)	Clamp Load (KN)	Tightening Torque (N * m)	Clamp Load (KN)	Tightening Torque (N * m)
M6 X 1	3.41	4.09	5.73	6.87	9.80	11.76	12.5	15
M7 X 1	4.90	6.86	8.24	11.5	14.1	19.72	18.0	25
M8 X 1.25	6.20	9.93	10.4	16.7	17.8	28.55	22.8	36
M10 X 1.5	9.8	19.7	16.5	33.1	28.3	56.55	36.1	72
M12 X 1.75	14.3	34.3	24.0	57.7	41.1	98.63	52.5	126
M14 X 2	19.5	54.6	32.8	91.8	56.1	157	71.6	200
M16 X 2	26.6	85.2	44.7	143	76.5	245	97.7	313
M18 X 2.5	32.5	117	54.7	197	93.6	337	120	430
M20 X 2.5	41.5	166	69.8	279	119	478	153	610
M22 X 2.5	51.4	226	86.4	380	148	650	189	830
M24 X 3	59.8	287	101	483	172	826	220	1055
M27 X 3	77.8	420	131	706	224	1208	286	1543
M30 X 3.5	95.1	571	160	959	273	1641	349	2095
M33 X 3.5	118	776	198	1305	338	2233	432	2851
M36 X 4	138	997	233	1676	398	2868	509	3662
M39 X 4	165	1290	278	2170	476	3711	608	4739

Tightening Torque =  $K * D * P$

$K = 0.2$  (dry,unlubricated)

Clamp Load (P) = 75% of the Proof Load

D = Nominal Thread Size

The values presented in these tables are representative and have been compiled for the user's benefit. Results can be influenced by any number of variables including 1) excessive lubrication, 2) excessive design clamp load, 3) nicked or binding threads, 4) non-parallel mating surfaces, and 5) inadequate torque control, to name a few. Therefore, Load expressly disclaims liability of any kind associated with the application of the data shown herein.

**English Units: (Fine Thread Series)**

Thread Size and Pitch	GRADE 1		GRADE 2		GRADES 5, 5.2 & 5.1		GRADES 8, 8.1 & 8.2	
	Clamp Load (lb)	Tightening Torque (ft-lb)	Clamp Load (lb)	Clamp Load (ft-lb)	Clamp Load (lb)	Tightening Torque (ft-lb)	Clamp Load (lb)	Tightening Torque (ft-lb)
6 - 40	251	0.58	419	0.96	647	1.49	914	2.10
8 - 36	365	1.00	608	1.66	940	2.57	1327	3.63
10 - 32	495	1.57	825	2.61	1275	4.04	1800	5.70
12 - 28	639	2.30	1064	3.83	1645	5.92	2322	8.36
1/4 - 28	901	3.75	1502	6.26	2321	9.7	3276	13.7
5/16 - 24	1436	7.48	2393	12.5	3698	19.3	5220	27.2
3/8 - 24	2173	13.6	3622	22.6	5597	35.0	7902	49.4
7/16 - 20	2938	21.4	4896	35.7	7567	55.2	10683	77.9
1/2 - 20	3958	33.0	6596	55.0	10194	84.9	14391	120
9/16 - 18	5024	47.1	8374	78.5	12941	121	18270	171
5/8 - 18	6336	66.0	10560	110	16320	170	23040	240
3/4 - 16	9232	115	9232	115	23779	297	33570	420
7/8 - 14	12598	184	12598	184	32449	473	45810	668
1 - 12	16409	273	16409	273	36797	613	59670	995
1-1/8 - 12	21186	397	21186	397	47508	891	77040	1445
1-1/4 - 12	26557	553	26557	553	59552	1241	96570	2012
1-3/8 - 12	32546	746	32546	746	72983	1673	118350	2712
1-1/2 - 12	39130	978	39130	978	87746	2194	142290	3557

Tightening Torque = K \* D \* P  
 K = 0.2 (dry.unlubricated)  
 Clamp Load (P) = 75% of the Proof Load  
 D = Nominal Thread Size

**Metric Units: (Fine Thread Series)**

Thread Size and Pitch	CLASS 4.6		CLASS 5.8		CLASS 9.8		CLASS 10.9	
	Clamp Load (KN)	Tightening Torque (N*m)	Clamp Load (KN)	Tightening Torque (N*m)	Clamp Load (KN)	Tightening Torque (N*m)	Clamp Load (KN)	Tightening Torque (N*m)
M8 X1	6.64	10.6	11.2	17.9	19.1	30.6	24.4	39.0
M10 X 1.25	10.4	20.7	17.4	34.9	29.8	59.7	38.1	76.2
M12 X 1.25	15.6	37.5	26.2	63.0	44.9	108	57.3	138
M14 X 1.5	21.2	59.3	35.6	100	60.9	171	77.8	218
M16 X 1.5	28.3	90.6	47.6	152	81.4	261	104	333
M18 X 1.5	36.6	132	61.6	222	105	379	134	484
M20 X 1.5	46.1	184	77.5	310	133	530	169	677
M22 X 1.5	56.4	248	94.9	418	162	714	207	912
M24 X 2	65.1	312	109	525	187	899	239	1147
M27 X 2	84.1	454	141	763	242	1306	309	1667
M30 X 2	105	632	177	1062	303	1816	387	2319
M33 X 2	129	851	217	1431	371	2449	474	3127
M36 X 3	147	1056	247	1775	422	3036	538	3877
M39 X 3	175	1362	294	2290	502	3917	641	5001

Tightening Torque = K \* D \* P  
 K = 0.2 (dry.unlubricated)  
 Clamp Load (P) = 75% of the Proof Load  
 D = Nominal Thread Size

The values presented in these tables are representative and have been compiled for the user's benefit. Results can be influenced by any number of variables including 1) excessive lubrication, 2) excessive design clamp load, 3) nicked or binding threads, 4) non-parallel mating surfaces, and 5) inadequate torque control, to name a few. Therefore, Load expressly disclaims liability of any kind associated with the application of the data shown herein.

## A.8 Bluetooth Specifications

<b>Wireless:</b>	Class 2 Bluetooth radio
<b>Modulation Method(s):</b>	FHSS: GFSK
<b>Max Output Power Spectral Density:</b>	0.205mW/MHz
<b>Max RF Transmit Power:</b>	4dBm
<b>Antenna Gain for Bluetooth:</b>	PCB antenna, max gain of 0 dBi at 2.4 GHz
<b>Max RF Transmit Power + Antenna Gain = Max (EIRP) Output Power:</b>	4dBm + 0dBi = 4dB

### Electrical Characteristics

Parameter	Minimum	Type	Maximum	Units
Supply voltage (DC)	3.0	3.3	3.6	V
<b>Average Power Consumption</b>				
Radio ON (discovery or inquiry window time)		40		mA
Connected Idle (no sniffs)		25		mA
Connected Idle (sniff 100 ms)		12		mA
Connected with data transfer	40	45	50	mA
Deep slide idle mode		26		mA

### Radio Characteristics

Parameter	Freq. (GHz)	Min.	Typ.	Max.	Bluetooth Specification	Units
Sensitivity at 0.1% BER	2.402	-	-80	-86	≤ -70	dBm
	2.441	-	-80	-86		dBm
	2.480	-	-80	-86		dBm
RF Transmit Power	2.402	0	2	4	≤ 4	dBm
	2.441	0	2	4		dBm
	2.480	0	2	4		dBm
Initial Carrier Frequency Tolerance	2.402	-	5	75	75	kHz
	2.441	-	5	75		kHz
	2.480	-	5	75		kHz
20dB bandwidth for modulated carrier		-	900	1,000	≤ 1,000	kHz
Drift (Five slots packet)		-	15	-	40	kHz
Drift Rate		-	13	-	20	kHz
$\Delta f_{1_{avg}}$ Max Modulation	2.402	140	165	175	> 140	kHz
	2.441	140	165	175		kHz
	2.480	140	165	175		kHz
$\Delta f_{2_{avg}}$ Min Modulation	2.402	140	190	-	115	kHz
	2.441	140	190	-		kHz
	2.480	140	190	-		kHz

## Range Characteristics

Range	Distance
After One Wall	55 feet
After Two Walls	60 feet
After Three Walls	36 feet

The range values are approximate and may vary depending on RF environment. Bluetooth hops in a pseudo-random fashion over the 79 frequencies in the ISM band to adapt to the interference, hence range depends on RF interference environment.





**World Area Configuration Centers (WACC) offer sales support, service, inventory and commissioning to our global customers. Choose the WACC or sales office nearest you:**

***NORTH & SOUTH AMERICA***

19200 Northwest Freeway  
Houston TX 77065  
USA  
T +1 281 477 4100

Av. Hollingsworth  
325 Iporanga Sorocaba  
SP 18087-105  
Brazil  
T +55 15 3413 8888

***ASIA PACIFIC***

No. 9 Gul Road  
#01-02 Singapore 629361  
T +65 6777 8211

No. 1 Lai Yuan Road  
Wuqing Development Area  
Tianjin 301700  
P. R. China  
T +86 22 8212 3300

***MIDDLE EAST & AFRICA***

P. O. Box 17033  
Jebel Ali Free Zone  
Dubai  
T +971 4 811 8100

P. O. Box 10305  
Jubail 31961  
Saudi Arabia  
T +966 3 340 8650

24 Angus Crescent  
Longmeadow Business Estate East  
P.O. Box 6908 Greenstone  
1616 Modderfontein Extension 5  
South Africa  
T +27 11 451 3700

***EUROPE***

Holland Fasor 6  
Székesfehérvár 8000  
Hungary  
T +36 22 53 09 50

Strada Biffi 165  
29017 Fiorenzuola d'Arda (PC)  
Italy  
T +39 0523 944 411

For complete list of sales and manufacturing sites, please visit [www.emerson.com/actuationtechnologieslocations](http://www.emerson.com/actuationtechnologieslocations) or contact us at [info.actuationtechnologies@emerson.com](mailto:info.actuationtechnologies@emerson.com)

[www.emerson.com/eim](http://www.emerson.com/eim)

©2018 Emerson. All rights reserved.

The Emerson logo is a trademark and service mark of Emerson Electric Co. EIM™ is a mark of one of the Emerson family of companies. All other marks are property of their respective owners.

The contents of this publication are presented for information purposes only, and while every effort has been made to ensure their accuracy, they are not to be construed as warranties or guarantees, express or implied, regarding the products or services described herein or their use or applicability. All sales are governed by our terms and conditions, which are available on request. We reserve the right to modify or improve the designs or specifications of our products at any time without notice.

**EIM™**

